

Department of the Army
Pamphlet 190-12

Military Police

Military Working Dog Program

Headquarters
Department of the Army
Washington, DC
30 September 1993

UNCLASSIFIED

SUMMARY of CHANGE

DA PAM 190-12
Military Working Dog Program

This revision--

- o Updates all points of contact, organizations, and mailing addresses (table 4-1).
- o Includes waiver or reception paragraph (para 1-4).
- o Includes a description of DD Form 1834 (Military Working Dog Service Record) (para 3-33).
- o Adds inventory procedures for explosive training aids (para 5-4b).
- o Authorizes exact duplication of any DA or DD forms generated Military Police Management Information System may be used in place of the Office printed version of the form.

Military Police

Military Working Dog Program

By Order of the Secretary of the Army:

GORDON R. SULLIVAN
General, United States Army
Chief of Staff

Official:

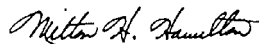

MILTON H. HAMILTON
Administrative Assistant to the
Secretary of the Army

History. This UPDATE printing publishes a revision of this publication. Because the publication has been extensively revised, the changed portions have not been highlighted.

Summary. This pamphlet explains policies, procedures, and responsibilities of

the U.S. Army Military Working Dog Program.

Applicability. This pamphlet applies to the Active Army, the Army National Guard, and the U.S. Army Reserve. It applies to all personnel who are involved in the care, training, and employment of military working dogs. This regulation applies during partial and full mobilization.

Proponent and exception authority. The proponent of this regulation is the Deputy Chief of Staff for Operations and Plans. The Deputy Chief of Staff for Operations and Plans has the authority to approve exceptions to this regulation that are consistent with controlling law and regulation. The Deputy Chief of Staff for Operations and Plans may delegate this authority in writing to a division chief within the proponent agency in the grade of colonel or the civilian equivalent.

Interim changes. Interim changes to this pamphlet are not official unless they are authenticated by The Administrative

Assistant to the Secretary of the Army. Users will destroy interim changes on their expiration dates unless sooner superseded or rescinded.

Suggested Improvements. Users are invited to send comments and suggested improvements through established command channels on DA Form 2028 (Recommended Changes to Publications and Blank Forms) directly to the HQDA (DAMO-ODL), 400 Army Pentagon, Washington, DC 20310-0400.

Distribution. Distribution of this publication is made in accordance with the requirements on DA Form 12-09E, block 2568, intended for command levels A, B, C, D, and E for Active Army, Army National Guard, the U.S. Army Reserve.

Contents (Listed by paragraph and page number)

Chapter 1

The Military Working Dog Program, page 1

Section I

Purpose and References, page 1

Purpose • 1-1, *page 1*

References • 1-2, *page 1*

Explanation of abbreviations and terms • 1-3, *page 1*

Waivers • 1-4, *page 1*

Section II

Program Concept, page 1

Historical basis • 1-5, *page 1*

The role of the military working dog • 1-6, *page 1*

Quality assurance • 1-7, *page 2*

Section III

Understanding Military Working Dogs, page 2

Advantages of dogs • 1-8, *page 2*

*This pamphlet supersedes DA Pam 190-12, 15 December 1984.

Contents—Continued

Superiority of senses • 1–9, *page 2*
Identifying MWD team missions • 1–10, *page 2*

Section IV

Starting a Military Working Dog Program, page 2
Determining need • 1–11, *page 2*
Kennel construction approval • 1–12, *page 3*
Manpower requirements • 1–13, *page 3*
Requests for authorization of military working dogs • 1–14, *page 3*
Requesting authorized military working dogs • 1–15, *page 3*
Obtaining equipment • 1–16, *page 4*

Section V

The Military Working Dog Section, page 4
Military working dog section organization • 1–17, *page 4*
Military working dog section composition • 1–18, *page 4*
Duties for military working dog personnel • 1–19, *page 4*
Military working dog handlers • 1–20, *page 5*
Military working dogs • 1–21, *page 5*
Replacement of military working dogs • 1–22, *page 6*
Disposition of disabled dogs • 1–23, *page 6*

Section VI

Operation of the Military Working Dog Section, page 6
Scheduling and employment • 1–24, *page 6*
Competitive events • 1–25, *page 6*
One dog—one handler • 1–26, *page 7*
Control • 1–27, *page 7*
Privately-owned and stray animals • 1–28, *page 7*

Chapter 2

Utilization, page 7

Section I

General, page 7
General information • 2–1, *page 7*
Use of force • 2–2, *page 7*

Section II

Employment of Patrol Dogs—Law Enforcement Operations, page 8
Walking patrols • 2–3, *page 8*
Mobile patrols • 2–4, *page 8*
Alarm responses • 2–5, *page 9*
Building checks and searches • 2–6, *page 9*
Vehicle parking lots • 2–7, *page 9*
Dependent housing and billet areas • 2–8, *page 9*
Traffic violations and accident investigations • 2–9, *page 10*
Identification and apprehension of individuals • 2–10, *page 10*
Protecting distinguished visitors • 2–11, *page 10*
Fixed post (stakeout) • 2–12, *page 10*
Entry control • 2–13, *page 10*
Protection of funds • 2–14, *page 10*
Confrontation management • 2–15, *page 10*
Tracking • 2–16, *page 10*
Riot and crowd control • 2–17, *page 11*

Contents—Continued

Civil disasters • 2-18, *page 12*

Section III

Employment of Patrol Dogs—Security Operations, page 12

Security planning • 2-19, *page 12*

Post selection • 2-20, *page 12*

Perimeter and distant support posts • 2-21, *page 13*

Close boundary (CB) posts • 2-22, *page 13*

External intrusion detection systems (IDS) • 2-23, *page 13*

Mobile security patrols • 2-24, *page 14*

Secondary response forces • 2-25, *page 14*

Section IV

Employment of Patrol Dogs—Combat Support Operations, page 15

General mission • 2-26, *page 15*

Area defense • 2-27, *page 15*

Warning and response procedures • 2-28, *page 15*

Listening posts, reconnaissance, and combat patrols • 2-29, *page 15*

Enemy prisoner of war (EPW) operations • 2-30, *page 16*

Mobilization and deployment • 2-31, *page 16*

Section V

Employment of Narcotics Detector Dogs, page 17

The drug problem • 2-32, *page 17*

The narcotics detector dog • 2-33, *page 17*

Legal aspects—narcotics detector dog teams • 2-34, *page 18*

Certification and decertification • 2-35, *page 18*

Section VI

Employment of Explosives Detector Dogs, page 19

The need for explosives detector dogs • 2-36, *page 19*

The explosives detector dog team • 2-37, *page 19*

Legal aspects—explosives detector dog teams • 2-38, *page 19*

Certification and decertification • 2-39, *page 20*

Bomb threat planning • 2-40, *page 20*

Response to bomb threats • 2-41, *page 20*

Positive responses • 2-42, *page 21*

Alternative immediate action • 2-43, *page 21*

Section VII

Reporting Use of Military Working Dogs, page 22

Incident reporting • 2-44, *page 22*

Title not used. • 2-45, *page 22*

Chapter 3

Training, page 22

Section I

Proficiency Training, page 22

General • 3-1, *page 22*

The need for training • 3-2, *page 22*

The principles of training • 3-3, *page 22*

Where to train • 3-4, *page 23*

When to train • 3-5, *page 24*

How to conduct proficiency training • 3-6, *page 24*

Contents—Continued

Decoys • 3–7, *page 25*

Section II

Military Working Dog Team Proficiency Standards, page 25

Proficiency standards • 3–8, *page 25*

Degrees of criticality • 3–9, *page 25*

Section III

Patrol Dog School Certification Requirements, page 26

Obedience commands • 3–10, *page 26*

Obedience course (semi-critical) • 3–11, *page 26*

Controlled aggression • 3–12, *page 26*

Building search (critical) • 3–13, *page 27*

Small arms fire (critical) • 3–14, *page 27*

Scouting or patrolling (critical) • 3–15, *page 27*

Vehicle patrol (semi-critical) • 3–16, *page 27*

Tracking (noncritical) • 3–17, *page 27*

Section IV

Patrol Dog Team Postgraduation Certification Requirements, page 27

Certification standards • 3–18, *page 27*

Obedience commands • 3–19, *page 27*

Obedience course (semi-critical) • 3–20, *page 28*

Controlled aggression • 3–21, *page 28*

Building search (critical) • 3–22, *page 28*

Gunfire (critical) • 3–23, *page 28*

Scouting or patrolling (critical) • 3–24, *page 29*

Vehicle patrol (semi-critical) • 3–25, *page 29*

Tracking (noncritical) • 3–26, *page 29*

Section V

Proficiency Training and Evaluation of Detector Dog Teams, page 29

Certification standards • 3–27, *page 29*

The narcotics detector • 3–28, *page 30*

The explosives detector • 3–29, *page 30*

Proficiency training of detector dogs • 3–30, *page 30*

Proficiency evaluation of detector dog teams • 3–31, *page 31*

Validation tests • 3–32, *page 31*

Section VI

Administrative Records, page 31

DD Form 1834 (Military Working Dog Service Record) • 3–33, *page 31*

DA Form 2807–R (Military Working Dog Training and Utilization Record) • 3–34, *page 31*

DA Form 3992–R (Narcotics or Explosives Detector Dog Training and Utilization Record) • 3–35, *page 32*

Section VII

Training of Nonhandler Military Police Personnel, page 33

Military police training • 3–36, *page 33*

Chapter 4

Controlled Substances Training Aids, page 38

General • 4–1, *page 38*

DEA registration • 4–2, *page 38*

Procurement of training aids • 4–3, *page 39*

Controlled substances accountability folder • 4–4, *page 40*

Destruction of training aids • 4–5, *page 41*

Contents—Continued

- Security requirements • 4–6, *page 41*
- Control of issue, return, and use • 4–7, *page 43*
- Form procurement and control • 4–8, *page 44*
- Use of synthetic drug training aids • 4–9, *page 44*

Chapter 5

Explosives Training Aids, *page 55*

- General • 5–1, *page 55*
- Explosives used for training • 5–2, *page 55*
- Explosives characteristics • 5–3, *page 56*
- Procurement of explosives training aids • 5–4, *page 58*
- Cutting training aids • 5–5, *page 59*
- Storing explosives • 5–6, *page 59*
- Issue and turn-in procedures • 5–7, *page 59*
- Vehicle transportation requirements • 5–8, *page 59*
- Explosives safety • 5–9, *page 60*
- Explosives safety training • 5–10, *page 60*
- Explosives safety requirements • 5–11, *page 60*

Chapter 6

Health, Care, and Feeding, *page 61*

Section I

- Veterinary Medical Care, page 61*
- Veterinary services • 6–1, *page 61*
- Veterinary responsibilities • 6–2, *page 61*

Section II

- Diseases and Parasites, page 62*
- Disease prevention • 6–3, *page 62*
- Contagious diseases • 6–4, *page 62*
- Parasite infestations • 6–5, *page 63*
- External parasites • 6–6, *page 63*
- Internal parasites • 6–7, *page 64*
- Noninfectious diseases of dogs • 6–8, *page 65*

Section III

- Medication and First Aid, page 65*
- Special medication • 6–9, *page 65*
- First aid • 6–10, *page 65*
- Physical restraint • 6–11, *page 66*
- Fractures • 6–12, *page 66*
- Wounds • 6–13, *page 66*
- Burns • 6–14, *page 67*
- Shock • 6–15, *page 67*
- Artificial respiration • 6–16, *page 67*
- Snake bites • 6–17, *page 67*
- Foreign objects in the mouth • 6–18, *page 67*
- Poisonous substances • 6–19, *page 68*
- Overheating • 6–20, *page 68*
- Causes of bloat • 6–21, *page 68*

Section IV

- Care of dogs, page 68*
- Required sanitation • 6–22, *page 69*
- Grooming and inspection • 6–23, *page 69*

Contents—Continued

Feeding dogs • 6–24, *page 71*

Chapter 7

Kennel Facilities, *page 72*

Section I

Kennel and Support Facilities, page 72

Kennel requirements • 7–1, *page 72*

Master planning • 7–2, *page 73*

Kennel components • 7–3, *page 73*

Standardization • 7–4, *page 74*

Kennel site selection • 7–5, *page 74*

Standard permanent kennel, 4–18 dogs • 7–6, *page 74*

Large permanent kennel, 19 or more dogs • 7–7, *page 74*

Semipermanent kennel • 7–8, *page 75*

Kennel support building size limits • 7–9, *page 75*

Ventilation system • 7–10, *page 75*

Heating • 7–11, *page 76*

Air-conditioning • 7–12, *page 76*

Temperature climate kennel • 7–13, *page 76*

Frigid climate kennel • 7–14, *page 76*

Plumbing • 7–15, *page 76*

Lighting and electrical systems • 7–16, *page 77*

Public address system • 7–17, *page 77*

Structural safety and security • 7–18, *page 77*

Kennel partitions • 7–19, *page 77*

Louvers • 7–20, *page 77*

Kennel building floor • 7–21, *page 77*

Kennel fixtures • 7–22, *page 77*

Fencing • 7–23, *page 77*

Parking and sidewalks • 7–24, *page 78*

Training area • 7–25, *page 78*

Obedience course • 7–26, *page 78*

Exercise area • 7–27, *page 78*

Section II

Maintenance and Sanitation, page 78

Kennel maintenance • 7–28, *page 78*

Section III

Kennel Safety and Transportation of Dogs, page 78

Warning signs • 7–29, *page 78*

Safety measures and procedures • 7–30, *page 79*

Training area safety • 7–31, *page 79*

Safety in veterinary facilities • 7–32, *page 79*

Vehicle transportation • 7–33, *page 80*

Aircraft transportation • 7–34, *page 80*

Hot weather requirements • 7–35, *page 81*

Leaving dogs unattended • 7–36, *page 81*

Section IV

Security Requirements for Kennels, page 81

Risk analysis • 7–37, *page 81*

Designing for security • 7–38, *page 81*

Operational security • 7–39, *page 81*

Contents—Continued

Minimum kennel security requirements • 7–40, *page 82*

Chapter 8

Authorized Equipment, *page 95*

General • 8–1, *page 95*

Initial issue equipment • 8–2, *page 95*

Organizational equipment • 8–3, *page 96*

CTA 50–900 • 8–4, *page 96*

CTA 50–970 • 8–5, *page 96*

Care of equipment • 8–6, *page 96*

Support vehicles • 8–7, *page 97*

Training aids weight scale • 8–8, *page 97*

Approved locking devices • 8–9, *page 97*

Chapter 9

Inspections, *page 98*

Section I

Operational Inspection Guidelines, page 98

General • 9–1, *page 98*

Section II

Facilities, page 98

Kennels • 9–2, *page 98*

Kennel support building • 9–3, *page 99*

Training and exercise areas • 9–4, *page 99*

Section III

Equipment, page 99

Leather and metal • 9–5, *page 99*

Supplies • 9–6, *page 99*

Section IV

Appearance and Condition of Dogs, page 100

Appearance • 9–7, *page 100*

Physical condition • 9–8, *page 100*

Section V

Veterinary inspections • 9–9, *page 100*

Veterinary instructions • 9–10, *page 100*

Veterinary support • 9–11, *page 100*

Section VI

Use and Training, page 100

Use • 9–12, *page 100*

Training • 9–13, *page 101*

Handler knowledge • 9–14, *page 101*

Demonstration of proficiency • 9–15, *page 101*

Section VII

Training Aids Accountability, page 101

Narcotics training aids • 9–16, *page 101*

Explosives training aids • 9–17, *page 101*

Section VIII

Records, page 101

Contents—Continued

Administrative and medical records • 9–18, *page 101*

DA Form 2807–R • 9–19, *page 102*

DA Form 3992–R • 9–20, *page 102*

Controlled substances training aids accountability folder • 9–21, *page 102*

Appendixes

A. References, *page 103*

B. Military Working Dog Authorizations, *page 106*

Table List

Table 7–1: Kennel support building size limits, *page 75*

Table 8–1: Dog training equipment authorized in CTA 50–900, *page 97*

Table 8–2: Military working dog and kennel facility equipment authorized in CTA 50–970, *page 98*

Figure List

Figure 3–1: Obedience course, *page 34*

Figure 3–2: Sample completed DA Form 2807–R, *page 35*

Figure 3–3: Sample completed DA Form 3992–R, *page 36*

Figure 3–3: Sample completed DA Form 3992–R—Continued, *page 37*

Figure 4–1: DEA field divisions and district/resident offices (Office, Address, and Telephone), *page 44*

Figure 4–2: DEA field division and district/resident office map, *page 48*

Figure 4–3: Sample completed DEA Form 225—Schedule I, *page 49*

Figure 4–4: Sample completed DEA Form 225—Schedule II, *page 50*

Figure 4–5: Sample completed DA Form 4608—R, *page 51*

Figure 4–6: Sample completed DA Form 4607—R, *page 52*

Figure 4–7: Sample completed DA Form 4607—R, *page 53*

Figure 4–8: Sample completed DA Form 4608—R (weight check), *page 54*

Figure 6–1: External anatomical parts, *page 72*

Figure 7–1: Standard kennel building shell, *page 82*

Figure 7–2: Sample floor plan, indoor kennel, *page 83*

Figure 7–3: Sample kennel support building, 435SF, *page 84*

Figure 7–4: Sample kennel support building, 500SF, *page 85*

Figure 7–5: Sample kennel support building, 500SF, *page 86*

Figure 7–6: Sample kennel support building, 875SF, *page 87*

Figure 7–7: Large permanent kennel, *page 88*

Figure 7–8: Semipermanent kennel, *page 89*

Figure 7–9: Specifications for barrels and tunnel, *page 90*

Figure 7–10: Specifications for steps, *page 91*

Figure 7–11: Specifications for jumps, *page 92*

Figure 7–12: Specifications for window obstacle, *page 93*

Figure 7–13: Specifications for “A” frame, *page 94*

Figure 7–14: Specifications for dogwalk, *page 95*

Glossary

Index

Chapter 1

The Military Working Dog Program

Section I

Purpose and References

1-1. Purpose

This pamphlet explains policies, procedures, and responsibilities for the direction, management, and control of the U.S. Army Military Working Dog (MWD) program. This pamphlet complements, and must be used with, AR 190-12 which prescribes Army policy and requirements. Other primary sources of information include AFR 400-8/AR 700-81/OPNAVINST 10570.1/MCO 20570.1 (hereafter referred to as AR 700-81). This pamphlet provides extensive guidance, standards, and information regarding training and utilization of MWD teams, controlled substances and explosives training aids, veterinary care, kennel facilities, dog handling equipment, and inspections. It provides the commander, the kennelmaster, and the handler with the information needed to maintain a proficient and operationally effective unit MWD program.

1-2. References

Required and related publications and prescribed and referenced forms are listed in appendix A.

1-3. Explanation of abbreviations and terms

Abbreviations and special terms used in this pamphlet are explained in the consolidated glossary.

1-4. Waivers

When provisions of this regulation cannot be met, major Army commands (MACOMs) may request a waiver, as appropriate. Requests for waivers will be forwarded in writing to HQDA(DAMO-ODL-S), 400 Army Pentagon, Washington, DC 20310-0400. Waivers normally will be granted for a period of one year and may be extended only after a review of the circumstances necessitating the extension. Requesting activity will maintain a record of approved waiver.

Section II

Program Concept

1-5. Historical basis

Dogs have been used by people to help protect themselves and their property since ancient times. Trained dogs have been used by most of the world's military forces since the first military units were organized. From these ancient beginnings, the MWD's training has been continuously refined to produce a highly sophisticated and versatile extension of the soldier's own senses. Even the most complex machines remain unable to duplicate the operational effectiveness of a properly trained MWD. The MWD's unique capabilities are used by the military police (MP) to:

- a. Secure installation and property.
- b. Help enforce military laws and regulations.
- c. Increase the effectiveness of the combat support provided by the MPs.

1-6. The role of the military working dog

Like other highly specialized items of equipment, MWDs complement and enhance the capabilities of the MP. When used by existing MP organizations, MWD teams enable the MP to perform their mission more effectively and, in many cases, with significant savings of manpower, time, and money. MWD teams also provide a strong psychological deterrent to potential offenders.

- a. The patrol dog is tolerant of people and can be used in almost any area of an installation including airfields, housing, shopping, and industrial areas. Patrol dog teams are used with law enforcement and security patrols to:
 - (1) Enhance the rear area protection capability.
 - (2) Search, scout, and track.
 - (3) Observe from listening or observation posts.
- b. Detection dog teams are trained to detect controlled substances or explosives used to construct explosive devices that threaten, damage, or destroy personnel or property.
- c. The MWD team's specialized capabilities make it one of the most effective tools available to the commander for combat support, security, and law enforcement. As the only live equipment employed Army-wide, the dog's continuing proficiency depends on realistic daily training and care. Skills which are not practiced or used can be lost. The assignment of dogs and handlers together as active teams is critical to their continuing effectiveness.

1-7. Quality assurance

Every level of command within the Army has specific responsibilities for making sure that the MWD program is properly established and efficiently managed. This includes ensuring that operational units are provided with trained dogs and handlers to form teams, and the necessary equipment and facilities to maintain effective local MWD programs. The Air Force is the executive manager of the MWD program for the Department of Defense (DOD), and is responsible for the procurement, initial training, and initial distribution of MWDs used by the military services and several Federal agencies. Specific responsibilities are per AR 190-12.

Section III

Understanding Military Working Dogs

1-8. Advantages of dogs

A dog can be trained to respond consistently to certain sensory stimuli (odors, scents, and so forth) to alert the handler. If the dog's reaction to selected stimuli is always rewarded by the handler, the reward reinforces the dog's behavior, motivating the dog to repeat the actions. A properly trained handler learns to recognize the dog's reactions and to recognize the source because of the characteristics of the reaction learned during training.

1-9. Superiority of senses

Under almost any set of circumstances, a properly trained dog can smell, hear, and visually detect movement better than a person. Trained dogs respond to selected stimuli and alert their handlers to that which they have been trained to detect. The dogs' detection abilities can be inconsistent; however, some variance is normal and must be considered when evaluating a dog's performance.

1-10. Identifying MWD team missions

The following should be considered when evaluating the possible use of MWD teams:

a. The task to be performed.

(1) *Deterrence.* The obvious presence and well-published activities of the MWD teams can successfully deter trespassers, vandals, violent persons, and so forth.

(2) *Detection.* If the desired task is to deter unauthorized or suspect individuals, the team should be assigned to a location and during a time of day or night when visual, sound, and odor distractions are at a minimum. Examples include patrolling shopping or industrial areas after normal operating hours, patrolling a housing area during duty hours or at night, patrolling an airfield or aircraft maintenance area after normal duty hours, or searching a supposedly unoccupied building. Narcotics and explosives detector dogs (EDDs) are trained to perform their detection skills under an extremely wide range of conditions so that location and time of day are not critical factors.

b. Other tasks. Patrol dogs also are trained to apprehend suspects at or near a crime scene, stop those who may attempt to escape, and to protect their handlers from harm. Some patrol dogs may be able to track suspects who have left the scene of a crime. Chapters 2 and 3 provide more details regarding the variety of ways that patrol dogs can be used.

Section IV

Starting a Military Working Dog Program

1-11. Determining need

The installation provost marshal (PM) or the MP unit commander must take the initiative to establish the local MWD program. The specific needs must be determined and the costs of the program must be justified. There is no easy formula to determine the number and type of MWD teams needed at any particular unit or installation. The decision process involves a thorough risk and crime analysis, and an accurate evaluation of the requirements of the entire MP mission. Normal, emergency, and contingency conditions will be analyzed for all security, law enforcement, and combat support missions.

a. Some of the factors to consider when determining the need for MWD teams include:

- (1) The unit mission.
- (2) The size of the unit's area of responsibility.
- (3) The size of the installation population or the number of personnel to be served by the unit.
- (4) Incident rates for appropriate crimes against property (for example, housebreaking, burglary, vandalism), crimes of violence (for example, assault, rape, bomb threats, and incidents), and drug usage (criminal cases, quantity of substances seized, level of self-admitted drug abuse, urinalysis test results, and so forth).
- (5) Present capability and the commitment of a portion of the manpower resources as handlers.
- (6) The types of terrain on the installation or in the probable areas of deployment.
- (7) The types of combat support missions for which MWD teams can be used.
- (8) The number of installation facilities or areas that can be more adequately protected because of the availability or

use of MWD teams. Included would be hospital parking areas, soldier and dependent housing areas, warehouses, airfields, installation entry points, munitions storage areas, retail facilities, and stadiums.

(9) The capabilities and limitations of MWD teams when assigned to certain types of duties. (For more information, see chap 2.)

(10) Additional considerations or guidelines to use in determining the need for a dog program (or for determining the number of dogs needed in a program) are contained in appendix B.

b. Probably the most difficult obstacles to overcome in order to establish a unit or installation MWD program concern the cost and construction of required kennel facilities. Kennel facilities should be constructed before dogs begin to arrive, but must be completed and available within one year after the dogs begin to arrive. Therefore, planning for MWD teams requires an early commitment to provide resources and construct the necessary kennel facilities. When planning for a MWD program, the PM or MP unit commander should ensure that the advantages of adding MWD teams to the MP force and the associated costs are justified by reasonable expectations of reduced crime rates and increased security. Accordingly, the justification should consider such factors as the following:

- (1) Increasing the effectiveness of the MP.
- (2) The additional areas that can be protected using MWD teams.
- (3) The additional tasks that can be done with MWD teams that cannot be done, or cannot be done as well, with present manpower and equipment resources.

1-12. Kennel construction approval

Once the need and justification for a MWD program are established, the PM or MP unit commander initiates a request to the installation facilities engineer to develop the kennel facility design. Chapter 7 gives extensive guidance on kennel design and location that will meet local conditions and requirements. The standard designs significantly lower the cost of kennel facilities. Cost must be kept as low as possible to ensure that funding can be provided; therefore, kennels should not use expensive construction materials when less expensive materials accomplish the same purpose. (Some features such as the separation between kennels, ventilation, and safe electrical connections are necessary.) Before the kennel design has been finalized, the activity or installation veterinarian should be consulted to ensure that minimum veterinary requirements are included in the final design. After kennel designs are completed and construction costs estimated, the kennel project is submitted for approval and funding to the installation commander. The request for authorization of MWD teams must include the statement that the commitment has been made to fund and build kennels.

1-13. Manpower requirements

Approval for manpower requirements requires identifying the specific MP or civilian positions (by paragraph and line number) on the unit modified table of organization and equipment (MTOE) or table of distribution and allowances (TDA) which will be the handlers and kennelmaster. The request for change to authorization must identify the correct additional skill identifier (ASI) for the types of dogs and handlers being requested, and the grades must be appropriate (E4 and above, as prescribed in AR 611-201). The request for change to the personnel authorization (addition of the ASI to an authorized or required MP position) normally is approved by the appropriate major Army command (MACOM). The approved manpower authorization may be used (after the request for authorization for dogs has been approved) as the basis for requesting handler training. Approved manpower spaces must be on MTOE/TDA for six or more months before personnel are needed to give enough lead time for any assignment action.

1-14. Requests for authorization of military working dogs

Requests for authorization of MWDs and their shipping crates are submitted through command channels according to AR 310-34 and AR 310-49 on DA Form 4610-R (Equipment Changes in MTOE/TDA). Part I is self-explanatory. The request for authorization must identify the nomenclature and line item number (LIN) for the type dogs being requested, as well as specify the number of dogs of each type being requested in Part II. Part III, Personnel, also should be completed so the approving authority has verification that the correct handlers (by number, ASI, and rank/grade) are being requested. Part IV, Justification, contains a complete justification for the dogs being requested as required by AR 190-12. If additional space is needed, continue on plain white, letter-size paper. DA Form 4610-R is forwarded through command channels as a letter request for authorization of equipment. Approval authority for all requests for authorization of MWDs is at Headquarters, Department of the Army (DALO-EARA-A).

1-15. Requesting authorized military working dogs

a. The approved request for authorization of MWDs may be used as the authorization document to submit Military Standard Requisitioning and Issue Procedures (MILSTRIP) requisitions to obtain authorized dogs. MILSTRIP requisitions are submitted via message to Commander, U.S. Army Aviation and Troop Command (ATCOM), ATTN: AMSTR-MSFC, 4300 Goodfellow Blvd., St. Louis, MO 63120-1798. ATCOM will acknowledge receipt of the requisition and prepare a Military Interdepartmental Purchase Request (MIPR), which is forwarded to the 341st Military Working Dog Training Squadron. A veterinary letter must accompany any MILSTRIP requisition when requesting a one year or less replacement MWD. MILSTRIP requests should not contain the words "emergency" or

“urgent.” If a unit believes it has an emergency or urgent need for a MWD, the unit should contact ODCSOPS (DAMO–ODL), before submitting a MILSTRIP requisition. (See AR 190–12 for further guidance.)

b. All dogs are trained by the 341st Military Working Dog Training Squadron, Lackland AFB, TX. These dogs are used to fill MILSTRIP requisitions and as training aids for handler training. Requisitions are filled on a first–come, first–serve basis; therefore, new or replacement requisitions for MWDs should be submitted as soon as a requirement is identified.

1–16. Obtaining equipment

Equipment needed to support the unit MWD program is listed in chapter 8. Individual items such as leashes, collars, and muzzles are shipped by the 341st Military Working Dog Training Squadron with the dog. The unit orders feed pans, water buckets, arm protectors, protective suits, other support items, and replacement equipment through normal supply channels.

Section V

The Military Working Dog Section

1–17. Military working dog section organization

There is no standard organizational structure because of the many types of units and many functions which may be performed by MWD teams. Usually, the kennel operation and MWD team training responsibilities are assigned to the kennelmaster. Operational control of MWD teams may be assigned to other leaders and depends on the mission of the unit and the number of MWD teams. The kennelmaster and each of the handlers are responsible for advising the officer or noncommissioned officer (NCO) who is assigned operational control of one or more MWD teams, how to best utilize the team. Operational control may be retained by the commander, delegated to a platoon leader or platoon sergeant, or attached to the PM section with operational control assigned to a member of the PM’s staff.

1–18. Military working dog section composition

The MWD section is composed of the kennelmaster, the handlers, and the MWDs. Larger kennels may have an assistant kennelmaster. One or more senior handlers may be assigned responsibilities as trainers. When manpower is available, other personnel may be used for kennel support.

1–19. Duties for military working dog personnel

a. *Kennelmaster.* The kennelmaster is the noncommissioned officer in charge (NCOIC) of the MWD section. The kennelmaster directly supervises the kennel operation, is responsible for all training, and ensures that MWD team proficiency is maintained. The kennelmaster supervises the care and feeding of the dogs, coordinates training and duty schedules, ensures that the administrative, accountability, and medical records are maintained, obtains all training support requirements, and supervises the kennel facility maintenance. In summary, the kennelmaster has direct supervisory responsibility for the unit MWD program. The requirements for assignment as a kennelmaster are prescribed in AR 190–12. Because of a kennelmaster’s unique expertise, he or she should be a direct participant in all planning for the use of MWD teams. The kennelmaster’s duties and required tasks include, but are not limited to:

(1) Knowing the mission of the MP unit or the unit to which MWD teams are attached, and how the MWD teams aid in accomplishing the mission.

(2) Knowing the threats to and vulnerabilities of personnel and resources being protected by dog teams which include:

(a) Assisting leaders in preparing operating procedures and instructions for the utilization of MWD teams.

(b) Training handlers according to the operating procedures so that teams are operationally efficient and dependable.

(3) Developing and implementing a comprehensive MWD team training program.

(4) Making sure that MWD teams are skilled in their team functions by frequently evaluating team proficiency and duty performance.

(5) Making appropriate provisions for the health, safety, and care of assigned dogs, and ensuring that each handler properly cares for his or her assigned dog.

(6) Making sure that each handler understands the physical and psychological characteristics and capabilities of their dog, the basic principles of dog training, and the advantages of using MWDs for MP missions. Also, the kennelmaster will make sure each handler is properly trained to detect and interpret the dog’s responses to persons, narcotics, explosives, or other stimuli to which the dog has been trained to respond.

(7) Obtaining equipment and supplies for the MWD section, as needed.

(8) Advising anyone assigned operational control of MWD teams on the best ways to use the teams.

(9) Performing trainer duties whenever a competent handler is not available.

b. *Kennel support.* A commander may provide a kennelmaster with personnel who are interested in becoming handlers or personnel who need to understand the training and functions of MWD teams. These kennel support personnel will be trained to perform sanitation and maintenance of the kennels, support building, and other areas and

equipment that are included in the kennel facility; they will be assisted by handlers whenever working in proximity to MWDs. Kennel support personnel will not be used to train and handle dogs. Persons who have been relieved of MP duties for misconduct, who are pending investigation or disciplinary action, or who are subject to other adverse personnel actions should not be assigned to kennel support duties.

c. MWD handlers. Each handler is personally responsible for their assigned dog. The handler trains, employs, feeds, cares for, cleans, and otherwise maintains his or her assigned dog in every way. The dog depends directly on the handler and, in keeping with the principle of one dog—one handler, the dog should never have to depend on anyone other than the assigned handler. The handler is responsible for the cleaning and maintenance of the dog's kennel. The handler is directly responsible to the kennelmaster for the operation, maintenance, and cleaning of the kennels, kennel support building, training area, exercise area, obedience course, and any other areas or equipment that are included in the kennel facility. The handler is responsible for maintaining accurate, complete, and current training and utilization records. The kennelmaster may assign handlers any other appropriate duties and responsibilities.

1-20. Military working dog handlers

MWD handlers are MP or civilian employee personnel who have been trained to use a very specialized piece of equipment. Military handlers are MP personnel first, capable of performing the standard MP tasks appropriate for their skill level. MP personnel who want to become MWD handlers should be volunteers. The standard of grade authorization (SGA) for dog handlers begins at E4. Handlers formally are trained and certified by the 341st Military Working Dog Training Squadron, Lackland Air Force Base, TX, or an equivalent formal course approved by the HQDA, ODCSOPS (DAMO-ODL-S). Handlers cannot and will not be trained through on-the-job training (OJT). Use of force policies and the need to be able to control the dog at all times make OJT of handlers unsafe and improper. The use of unqualified personnel to handle dogs also may subject the Army to unacceptable liability. At no time will an unqualified dog handler work with a MWD dog for any reason.

a. The prerequisites and standards for MP personnel who want to become a dog handler are prescribed in AR 190-12.

b. Personnel who successfully complete formal handler training may be stabilized in their present duty assignment according to Army policies. If stabilization of handlers is desirable, it may be obtained by reporting when the handler starts and when the handler successfully completes handler training to the Commander, US Total Army Personnel Command (PERSCOM), ATTN: TAPC-EPL-M, Alexandria, VA 22333-0400.

c. The installation or unit receiving a newly trained handler is responsible for the documentation of the handler ASI in the soldier's personnel records.

1-21. Military working dogs

All dogs trained and used as working dogs by the Army are procured by the 341st Military Working Dog Training Squadron, Lackland AFB, TX. Usually, only the Belgium Malinois and German Shepherd breed dogs are accepted for military use, but other breeds may be used for special purposes.

a. German Shepherd dogs are used as the standard breed because of their unique combination of traits. Shepherds are intelligent, dependable, predictable, easily trained, usually moderately aggressive, and can adapt readily to almost any climatic conditions. While many dog breeds exhibit some or most of these traits, the Shepherd more than any other breed, most consistently exhibits all of these traits.

b. Small breed dogs are being used in special situations as narcotics detector dogs. These dogs are trained only for detection and are not suitable for other duties. This limitation on their use means lower cost effectiveness than the patrol trained detector dogs, and requires the use of small breed dogs remain limited to special situations. Because of this lower cost effectiveness and because of the lack of a wartime mission for small breed detector dogs, the program has been eliminated. Small breed dogs in the system are to be replaced by attrition by the narcotic detector dog. Authorization documents must be changed to reflect this change.

c. The 341st Military Working Dog Training Squadron specifies the breed and other physical requirements for dogs offered for use in the MWD program. Dogs do not have to be purebred or registered, but must display the predominant characteristics of their breed. The 341st Military Working Dog Training Squadron will provide requirements upon request.

d. Since military duties demand strength and stamina, all dogs must be in excellent physical condition. Minor physical defects may be acceptable provided they do not impair the dog's ability to work. Dogs should be moderately aggressive and must not be gun shy.

e. The 341st Military Working Dog Training Squadron has prepared an evaluation packet for use by kennelmasters and veterinarians to field screen all dogs being offered for sale or donation to the military. This packet is available from MACOMs. Field screening helps to eliminate dogs that are clearly unacceptable for military use without the expense of shipping the dog to and from the 341st Military Working Dog Training Squadron. As a general rule, dogs will not be accepted from donors outside the customs territory of the United States.

f. The majority of dogs trained and used by the military services are purchased from the open market. Kennelmasters and handlers can help recruit qualified dogs. Anyone interested in donating or selling a dog to the U.S.

Government should contact the Program Manager, 341st Military Working Dog Training Squadron, Lackland AFB, TX 78236-5000, or (toll free) 1-800-531-1066.

1-22. Replacement of military working dogs

The method of replacing MWDs and MWD teams according to the team concept is prescribed in AR 190-12.

1-23. Disposition of disabled dogs

When an MWD becomes incapacitated and can no longer perform services beneficial to the Government, euthanasia of the dog is authorized.

a. Dogs are considered incapacitated and may undergo euthanasia:

- (1) To end suffering from diseases, injury, or permanent physical disability.
- (2) To prevent the spread of a contagious disease.
- (3) When they are fractious or too vicious for retraining.
- (4) When they are not fit to work because of medical or physical disabilities associated with old age.
- (5) When they cease to be effective.

b. Dogs do not undergo euthanasia solely because of advanced age if they continue to be physically capable of performing useful duty.

c. Before a dog undergoes euthanasia, written approval must be obtained from the first field grade rank (Major or above) commander in the supervisory chain of command of the unit owning the dog. A letter recommending euthanasia identifies the dog by name and tattoo number and specifies the reason for the recommendation. If the reason is medical, the recommendation must be supported by a physical evaluation from a veterinarian. The commander approves or disapproves the euthanasia by endorsement of the letter of recommendation.

d. The veterinarian may euthanize a dog without prior written approval of the appropriate commander in an emergency when a delay would cause undue suffering and pain to the dog. In this case, the veterinarian will document the circumstances and necessity for euthanasia by writing a letter to the appropriate commander.

e. Whenever a dog undergoes euthanasia, all medical and service records pertaining to the dog are sent to the 341st Military Working Dog Training Squadron where these records are maintained in a central records repository.

Section VI

Operation of the Military Working Dog Section

1-24. Scheduling and employment

The kennelmaster assists the commander or operations officer in developing duty schedules, duty cycles, duty hours, and methods of using MWD teams that best support MP operations. Scheduling must allow time for mandatory proficiency training and for the care of the dogs, kennels, and equipment.

a. The duty schedule must allow at least four hours each week for proficiency training in both patrol and detector tasks—eight hours for dual certified dogs. One period of four hours proficiency training each week is preferred, rather than shorter periods each day or two. Daily work schedules should provide one to two hours for feeding, grooming, and exercising the dogs, and for maintenance of equipment and kennel facilities.

b. Proficiency training should be conducted in both a training and a duty environment, and should include repetitive training on each of the dog's capabilities. Any deficiencies or weaknesses must be stressed during training to regain and maintain at least minimum proficiency.

c. Some exercising of the dog is desirable when dogs are taken out of the kennel for duty. Detector dogs should not be exercised to the extent that they begin to pant. If such exercise is necessary, they must be allowed to rest before being required to search.

d. MWD teams should be worked in a variety of duty positions each week so that the team is exposed to as many different situations as possible. The variation enhances team proficiency and keeps the dog from becoming bored or making stereotyped responses.

e. Patrol-trained detector dog teams perform normal patrol dog team duties when not needed for detection work. Patrol detector teams cannot be limited to detection duties only. Patrol detector teams need to maintain their patrol dog skills. Lack of exposure to patrol dog tasks can very quickly cause loss of proficiency.

1-25. Competitive events

MWD teams should be encouraged and allowed to participate in competitive events, seminars, conferences, and so forth, conducted by civil or MP agencies or officially recognized police canine associations. The exposure to competitive events permits a MWD team to develop skills, to see and learn advanced employment and training techniques, and to gain a better understanding of the function of the MWD. Although different tasks may be required or different methods may be used, the handler should be able to identify those methods and tasks that apply to military missions. In this way, the team's proficiency and effectiveness are enhanced.

1-26. One dog—one handler

A MWD team includes a handler and his or her assigned dog. The team concept joins a dog and handler together as a team. The team is not split unless the dog dies or the handler leaves the Army, the handler is trained with a different dog in one of the detector dog handler skills, or the handler is reassigned to a nonhandler duty position. The expense of training dog and handler as a team necessitates that dog and handler remain together for as long as possible. The permanent change of station (PCS) reassignment of dog and handler normally will be as a team. Dog and handler will not be separated unless the reassignment orders state the assignment is not as a MWD team or the dog is medically ineligible for reassignment.

1-27. Control

MWDs are worked on- or off-leash depending on the situation. Handlers must be able to control their dog whenever it is off-leash. Kennelmasters and trainers must closely observe off-leash training so that any off-leash control problems are quickly identified and corrected.

1-28. Privately-owned and stray animals

a. Only dogs which are procured and trained as MWDs are housed in U.S. Army kennel facilities. MWD handlers on temporary duty (TDY) must make advance arrangements with the kennelmasters at enroute or TDY locations for overnight kenneling of their assigned dog. Privately-owned animals, unit mascots, or stray animals will not be allowed to enter any MWD kennel facility.

b. Facilities used to house stray or abandoned animals will not be located with or operated as part of an MWD kennel facility. Personnel assigned to the MWD section will not be used to support stray apprehension or operation of stray or abandoned animal facilities. This prohibition exists to prevent contamination of the kennel and the potential spread of infectious diseases which may be carried by animals other than MWDs.

Chapter 2 Utilization

Section I General

2-1. General information

a. The patrol dog is the basic Army MWD. Some patrol dogs subsequently may be trained in additional skills, such as tracking, scouting, narcotics detection, and explosives detection. All of the MWD employment concepts which have been developed revolve around the basic skills of the Army patrol dog. All dog handlers, even those assigned to narcotics/contraband detector dogs are first trained as patrol dog handlers. The patrol dog handler training teaches handlers the importance of caring for and feeding their assigned dog, the importance of obedience and proficiency training, and helps handlers to develop complete understanding of their role in the MWD program.

b. The length of tours of duty for MWD teams should be consistent with the needs of the command, and schedules should consider the climate and terrain conditions which can enhance or reduce a dog team's effectiveness. Scheduling also should fully consider the time necessary for training the dog, caring for and feeding the dog, and kennel sanitation and maintenance. The standard for employment is approximately 30 hours per week, and at least four hours of proficiency training per week in each certified specialty. It may be necessary to periodically increase the frequency or length of proficiency training to compensate for or correct training or operational deficiencies. When proficiency training must be increased, there will be some tradeoff with utilization. However, it should be possible to maintain the utilization and proficiency training ratio. When both training and utilization consistently fall below the employment standard, a reduction of MWD team authorizations is indicated. Authorizations should be reduced to the number that can maintain the standard. Excess MWD teams should be reassigned to areas where they are needed.

c. There is no need to withdraw MWD teams from their posts during inclement weather. The dog's ability to detect an intrusion will still exceed that of his handler or many other physical, mechanical, or electrical intrusion detection systems (IDS). MWDs stationed in cold weather areas should be acclimated to their boots and blankets during training so the dogs will not resist wearing protective equipment when weather conditions necessitate its use.

d. Whenever possible, a handler should salute an approaching or passing officer. However, maintaining control of the dog is more critical. The action of the handler saluting and of an officer returning the salute could be misinterpreted by the dog as an attack on his handler and could result in the dog attacking the officer. If a salute cannot be safely rendered, an appropriate greeting should be given. Full attention should be given to controlling the dog if the officer elects to give a salute.

2-2. Use of force

a. The patrol dog is trained to perform the primary function of detecting the presence of unauthorized personnel and

warning its handler. Once the handler has been alerted, it becomes the responsibility of the handler to cope with the situation in the most appropriate manner. Frequently, the appropriate action is to keep the intruder or area under surveillance until other MP personnel can arrive. The secondary function of the patrol dog is to pursue, attack, and hold any intruder who attempts to avoid apprehension or escape from custody. However, releasing the dog constitutes the conscious application of physical force and, therefore, is governed by the use of force requirements of AR 190–14 and AR 190–12.

b. As a measure of force, release of a patrol dog to pursue, attack, and hold a person may result in physical injury to the person against whom the dog is released. As a result, AR 190–14 requires that all lesser means of force must be attempted when it is reasonable to do so. The duty of the MP, whatever the situation, is to apply only the minimum amount of force necessary to prevent escape or apprehend a person engaged in a criminal act. The handler also bears a distinct responsibility for the safety of innocent persons, including other MP personnel. Handlers must avoid releasing the dog to attack until the danger to innocent persons can be eliminated or minimized. One method of minimizing danger is to ensure that all MP personnel have been trained regarding the actions to take and the actions to avoid when working around MWDs. Trained MPs can then assist innocent persons who may be present in any area from inadvertently becoming the object of an MWD's attack.

c. When the handler determines that the dog should be released to attack, the handler should disconnect the leash so that the dog will not endanger itself because of a trailing leash.

Section II

Employment of Patrol Dogs—Law Enforcement Operations

2–3. Walking patrols

The patrol dog's contribution to the MWD team law enforcement efforts is most effective when the team is on foot. Some of the law enforcement duties that a patrol dog team can do as a walking patrol include checking or clearing buildings and patrolling parking lots, dependent housing areas, and troop billet areas. The following factors should be considered when planning patrol dog team walking patrols:

a. Since it is easily seen, a patrol dog used during daylight in congested areas provides a good psychological deterrent to certain crimes. Patrol dogs are tolerant of people, and the presence of a large number of people does not significantly reduce the patrol dog's usefulness, except as a detector.

b. More effective use of the patrol dog's detection ability can be made by using the patrol dog team during darkness or periods of reduced visibility and where there are fewer distractions. A person fleeing a crime scene at night may not be detected by the MPs, but a patrol dog normally will be able to detect and locate a fleeing suspect. When necessary and appropriate, the patrol dog also is much more effective at pursuing and holding the suspect.

c. A larger number of buildings and parking lots can more easily be checked or searched with a patrol dog team than by a single MP.

d. Periodic use of patrol dog teams around on-post schools, especially when school is starting and dismissing, may help deter potential vandals, child molesters, exhibitionists, and illegal drug activities.

e. Patrol dog teams also can provide effective security for communications facilities, military equipment, and command posts.

2–4. Mobile patrols

a. Giving patrol dog teams a mobile capability significantly increases their potential area of coverage and allows the teams to perform a greater range of functions during a duty shift. The team is normally unaccompanied, but other MPs may go with the team when the need arises.

b. Whenever possible, the mobile patrol dog team should be assigned a sedan, station wagon, or other passenger type vehicle. The patrol dog will always ride with the handler in the passenger compartment, regardless of the type vehicle. Placing portable kennels in the beds of pickups for transporting dogs is not appropriate for duty. It renders the dog unable to assist his handler, the dog does not stay alert, and the dog cannot protect itself.

c. While patrolling, the handler may allow the dog to be off-leash on the front or rear seat of the vehicle. The rear seat of the vehicle should only be used when a cage does not separate the dog and the handler. A stable platform should be provided to assist the dog in maintaining its position. Suitable platforms may be built locally by adding two 2-inch by 2-inch folding legs to one side of a 24-inch by 30-inch rectangle of 1/2-inch plywood. The length of the legs is determined by the distance from the top of the seat to the floor. The angle or curvature of some vehicle seats may require the addition of a spacer block between the seat and the platform to level the platform. The surface of the platform will be covered with hard rubber matting or other nonskid surface.

d. The dog is required to remain in the SIT position as much as possible to observe the surrounding and activities, and so the dog can be seen. The handler should never allow the dog to lie down or go to sleep, so the dog learns to distinguish between working time and resting time. To prevent eye injury from insects or other foreign objects, the dog must not be allowed to place its head out the window while the vehicle is moving.

e. Mobile patrols are most effective when the patrol dog team uses the ride-awhile, walk-awhile method. The team is able to cover a large patrol area and the periodic exercise helps to keep the dog alert.

2-5. Alarm responses

In responding to an alarm condition at facilities such as clubs, finance offices, or banks, the patrol dog team should be among the first MPs on the scene. The patrol dog may be used to search and clear the building and immediate area, and help with any apprehensions. If the patrol dog must be used to track a suspect, other persons should attempt to avoid contaminating the area with scents and tracks that may confuse the dog.

2-6. Building checks and searches

A patrol dog team is especially effective in checking and searching buildings such as commissaries, post exchanges, finance offices, banks, and warehouses.

a. The patrol dog team can check buildings visually while patrolling, and also can stop and dismount so the handler can physically check doors and windows. These checks should be made with the dog on-leash. To take maximum advantage of the dog's scenting ability, the handler should approach buildings from downwind.

b. If a building is open or forced entry is evident, patrol dog teams may be used to track hidden intruders from point of penetration to their location. Patrol dogs may be released to apprehend an intruder suspected of committing a serious offense when the only alternatives are escape or the use of deadly force.

(1) Prior to searching a building, the handler will determine whether to make the search with the dog on or off the leash. Some of the factors which must be considered include the following:

- (a) The time of day or night.
- (b) Evidence of forced entry.
- (c) The type and size of the building or area to be searched.
- (d) The danger to any innocent persons in the area.
- (e) The dog's ability to work off-leash.

(2) Prior to release of the dog inside a building or enclosed area, a clear voice warning will be given to any persons inside or in the area, to come out immediately, and that failure to comply with instructions will result in the release of a trained MWD. All persons will be cautioned that the dog may attack without warning, and that they could receive physical injuries. The handler will maintain voice control of his dog throughout the search.

(3) On-leash searches will be preceded by a warning similar to the one for off-leash searches. The searching team should be followed by at least one other MP to protect the search team.

2-7. Vehicle parking lots

a. Dog teams are effective in detecting and apprehending thieves and vandals in vehicle parking lots. Also, the presence of the patrol dog team may deter potential acts of theft and vandalism. The team can be most effective by alternating between vehicle and foot patrol of the parking lots. During hours of darkness, when there is no activity in a parking lot, the team should approach the lot from the downwind side. If the dog responds, the handler should locate and challenge the suspect for identification.

b. If a suspect tries to escape or avoid apprehension, and the handler is reasonably certain the suspect has committed or is attempting to commit a serious offense, the handler should give a clear warning to the suspect to halt. When lesser means of force have failed to stop the fleeing suspect, the patrol dog may be released to pursue, attack, and hold. If it is not safe to release the dog, the handler may attempt to follow the individual if the patrol dog has the ability to track.

2-8. Dependent housing and billet areas

a. Using patrol dogs in family housing or in the vicinity of troop billets helps deter and decrease criminal actions. Although the team should have the ability to move quickly from one area to another, actual patrolling of housing and billet areas should be mostly dismounted. Frequent contact with area residents helps to reinforce the dog's tolerance of people, while at the same time helping to build the confidence of the residents in the efforts of the MPs to keep their community safe and secure. The handler is responsible for determining how much socializing the dog needs and will accept without losing its desired aggressiveness. Community residents should not fear the patrol dog team, but they should have a healthy respect for the team's capabilities.

b. PMs, security officers, or MP commanders will establish procedures governing the release of a patrol dog in family housing or billet areas consistent with Army use of force policy. Apprehensions for minor offenses should not normally necessitate releasing the dog. Children involved in minor incidents, who fail to heed warnings to halt, should be followed to their quarters rather than releasing the dog to catch them. A patrol dog with an ability to track can be used very advantageously in both housing and billet areas with minimum risk to innocent persons. For example, if a "peeping tom" is reported, a dog team may successfully track and apprehend the offender. Tracking procedures are further discussed in paragraph 2-16.

2-9. Traffic violations and accident investigations

a. When a traffic stop is made, the patrol dog may accompany the handler on-leash without interfering with the issuing of traffic citations. Frequently, the presence of the dog will cause many violators to be more willing to cooperate.

b. MWD teams should not be used for traffic control or accident investigation duties. If exceptional circumstances require that they perform these duties, the dog should be secured in the vehicle. In warm weather, dogs left in vehicles can overheat in a very short time because of poor shade or poor ventilation. The handler must make sure there is adequate ventilation for the dog, but at the same time make sure that the dog is unable to get out of the vehicle to avoid potential injury to the dog. All windows need to be rolled up far enough to prevent the dog from trying to get out to avoid potential injury to the dog.

2-10. Identification and apprehension of individuals

To check identification or to apprehend, the handler should always warn the person(s) that if they display any hostility to the patrol dog or the handler, the dog will attack without command. After an apprehension, a search is always done with the patrol dog in the guard position. A backup MP patrol should be used to transport apprehended personnel. If the MWD team must transport apprehended personnel, the patrol dog should be positioned between the handler and the offender.

2-11. Protecting distinguished visitors

Patrol dog teams may assist in protecting distinguished visitors by providing security around quarters and conference sites, or by searching and clearing buildings.

2-12. Fixed post (stakeout)

The primary function of a patrol dog team on a fixed post is surveillance over an area or building. If used outside, the team should be located downwind where the dog can detect an intruder by scent, sound, or sight. If this is not possible, the team should be located so an intruder can be detected by sight or sound. When used inside, the dog depends mostly on its hearing. Other MPs may be used with dog teams on fixed posts.

2-13. Entry control

a. A patrol dog team may be used on gate duty or other entry control functions. The dog's primary function is deterrence and protection of the handler. Use of MWD teams for entry control, however, is not recommended because of the:

- (1) High volume of traffic.
- (2) Large number of distractions.
- (3) Reduction of the handler's ability to maintain positive control over the dog.

b. If circumstances necessitate using MWD teams at entry control points, the dog should not be confined inside a gate house where it could not respond to its handler if needed. Further, the MWD team would need to be frequently moved to other duties to keep the dog alert and proficient.

2-14. Protection of funds

a. Patrol dog teams, used to escort and safeguard funds, may deter some people from attempting to rob the courier. Unlike people, a patrol dog does not fear an armed or unarmed person and, if fired at, will pursue and attack. This is an important aspect of the patrol dog's training to emphasize during demonstrations and in news releases.

b. While escorting funds, the patrol dog team should follow the courier to observe anyone approaching. If a robbery is attempted, the patrol dog is released to attack. Couriers who are reluctant to ride in the same vehicle with the patrol dog should sit in a back seat with the MWD team in front, or ride in another vehicle with the MWD team following.

2-15. Confrontation management

Patrol dogs should be used cautiously in confrontation situations, since their presence could aggravate a situation. The Army use of force policy applies as much to confrontation situations as it does to any other type of situation. (See guidance in paras 2-2 and 2-17). A patrol dog handler who is confronted (for example, in a club or housing area) should avoid entering a building or a closed area alone with the patrol dog. The handler should use the minimum necessary force to withdraw safely from a confrontational situation and then immediately report the incident to his supervisor so that necessary actions can be taken.

2-16. Tracking

a. Not all patrol dogs have been trained to track. Among the dogs trained to track, not all have the same tracking ability. The kennelmaster must know which of his assigned patrol dogs are good trackers and use the best patrol dogs for tracking missions.

b. When the need for tracking arises, personnel who are on the scene should avoid the area and keep other personnel from entering the tracking area. This will reduce contamination of the area with extraneous or confusing scents.

c. To start the track, the patrol dog is taken to the last known location of the person to be tracked and allowed to find the scent. If there are any articles, such as clothing, that have the person's scent, the dog is allowed to smell them to help identify the correct scent. Any articles with the person's scent should be taken along on the track to remind the dog periodically of the correct scent.

d. To eliminate further contamination of the track, the dog team always precedes the search party. The search party should maintain sufficient distance to avoid distracting the dog and to allow the dog to return to an earlier point to regain a lost scent trail, if necessary.

e. The dog should begin tracking as soon as possible because success often depends on the strength of the available scent. The passage of time, wind strength, and other environmental conditions will affect the strength of the scent. Human scent adheres well to grass and brush which can improve the chances of success. Paved or gravel areas, and strong scents such as fertilizer, burned grass, or spilled oil or gasoline impede the tracking ability. Human scent remains longer on cool, moist ground. Direct sunlight, extremely dry ground, or heavy rain dissolves scent rapidly, making tracking more difficult.

f. During tracking, the dog may locate discarded items of evidence or clothing. Allow the dog to smell them but do not allow it to pick them up in its mouth.

g. The methods used to track lost personnel, especially children, are different from those used to track a fleeing suspect. Only dogs who have been trained to track successfully for lost personnel should be used for that purpose to avoid any danger of harming innocent persons.

h. The MWD will wear a tracking harness (NSN 3770-00-240-6620) for all tracking missions. At least 10 percent of the assigned patrol dogs (or at least one patrol dog) should be able to track a person on a trail at least four hours old for at least two miles over varied terrain.

2-17. Riot and crowd control

a. MWD teams will not be used for crowd control or direct confrontation with demonstrators unless determined to be absolutely necessary by the responsible commander. Use of patrol dog teams for direct confrontation with demonstrators is not recommended. In accordance with Army use of force policy, the application of physical force against a person who cannot reasonably be suspected of committing an offense is not appropriate. Presence in a crowd does not necessarily constitute an offense or a situation where it would be reasonable to apply the degree of physical force of a patrol dog. A patrol dog would not be used unless the person is engaged in some other readily apparent criminal behavior such as theft, destruction of property, or assault.

(1) The duty of the MP, whatever the situation, is to apply only the minimum amount of force necessary to prevent escape or effect a lawful apprehension of a person engaged in a criminal act. In a crowd situation, there is no certainty that a patrol dog will attack, pursue, and hold the person against whom the dog has been released. Therefore, under no circumstances, will dogs be released into a crowd.

(2) The high levels of confusion and excitement, and the large number of antagonists all contribute to the difficulty of employing patrol dogs properly. Frequently, the appearance of dogs at an angry crowd scene has resulted in an escalation of violence of the crowd. The crowd often will challenge the MPs to use the patrol dogs as a measure of force, particularly if a situation can be provoked that can later be interpreted or challenged as being an unreasonable use of force by the authorities. According to crowd psychology, the crowd reasons that when authorities act unreasonably, the crowd is then justified in also taking unreasonable actions. This includes criminal actions.

(3) The decision to employ patrol dogs must be weighed carefully by the responsible commander to be sure that if patrol dog teams are committed that all lesser means of force have been reasonably attempted and have failed. The commitment of MWD teams now comes only as an alternative to the use of deadly force to gain control of the situation. If a commander directs the employment of patrol dog teams for direct confrontation with demonstrators, the procedures listed below should be followed.

(a) During the otherwise peaceful stages of a confrontation, patrol dog teams should be held in reserve, out of sight of the crowd. As the situation worsens, dog teams may be moved forward to within sight of the crowd, but well away from the front lines.

(b) When committed to the front lines in direct confrontation, dogs are kept on short leash and allowed to bite when and only under the specific circumstances authorized by the responsible commander. Dogs will never be released into a crowd.

(c) Other riot control force personnel should be positioned approximately 10 feet from the patrol dog teams to prevent any unintentional bite injuries to riot control force personnel.

(d) In an open area with normal wind velocity, chemical riot control agents will not affect the patrol dog's ability to be both a physical and psychological deterrent. Handlers should, however, closely watch their dogs under such conditions. If the dogs show any signs of distress, have the dogs examined by a veterinarian as soon as possible.

(e) Patrol dog teams may be used to help apprehension teams catch and remove specific individuals in a group of demonstrators. In this role, the dog team is used only to protect the members of the apprehension team. The handler must exercise extreme caution in this situation because of the high level of activity and excitement. The dog will become extremely excited and agitated and could mistakenly bite or attempt to bite a member of the apprehension

team. The handler must maintain positive control over the dog and immediately redirect the dog's aggressiveness toward the demonstrators.

b. MWD teams are extremely useful in performing a variety of duties supporting riot control forces. For example, patrol dog teams can be used to:

- (1) Protect critical facilities.
- (2) Provide security for important persons.
- (3) Provide security for law enforcement personnel and equipment held in reserve.
- (4) Provide security for fire fighters and fire fighting equipment.
- (5) Secure access control points.
- (6) Provide security along crowd escape valves.
- (7) Provide perimeter patrolling or area patrolling after the crowd has dispersed.
- (8) Provide explosives detection.
- (9) Position patrol dog teams on the outer perimeter of large open areas to hold the crowd while other forces apprehend demonstrators.

c. Dog teams may be posted around holding areas and processing centers to prevent the escape or liberation of prisoners. Patrol dogs can be used in many locations and situations where manpower shortages preclude assigning adequate manpower for security missions. FM 19-15 describes many situations where the application of initiative on the part of MPs to employ patrol dogs will significantly alleviate potential security problems.

2-18. Civil disasters

When directed or approved by proper authority, MWD teams may be provided to a civilian community in a humanitarian or domestic emergency. Care must be exercised in any of these situations to avoid violations of section 1385, title 18, United States Code (more commonly known as the Posse Comitatus Act). The responsible commander should work closely with the following to closely supervise and direct the activities of any committed MWD teams:

- a.* The PM or security officer.
- b.* The MP commander.
- c.* The installation staff judge advocate (SJA).

Section III

Employment of Patrol Dogs—Security Operations

2-19. Security planning

The primary mission of patrol dog teams as assigned to security duties is to deter, detect, and help apprehend violators on Army property or to prevent access to Army resources by unauthorized personnel. Patrol dog teams may be used on almost any security post, but planners must be familiar with the capabilities of patrol dog teams so that teams can be assigned to those posts where they can be used most effectively.

a. Compared to one or more lone sentries, the patrol dog team offers a much greater intruder detection capability. In addition, it can cover a larger area. This increased probability of detection will, in many cases, discourage attempts by an intruder to gain access to resources. A well-trained team also has a better chance of locating and stopping an intruder.

b. A patrol dog team's effectiveness can be reduced when used on posts that deprive the team of the ability to adjust positions and maneuver to maximize natural abilities. For example, if the team's purpose is detection of intruders, placing the team in an area with a lot of people and constant activity deprives the team of most of its detection capability. If deterrence is the purpose of placing the dog team in high traffic areas, some benefit is gained because of the high visibility of the team. However, any deterrent benefit that may be gained can be lost to the degree that people realize that the team has been deprived of its detection capability. Using a patrol dog team on a security post where there is little room to maneuver to take advantage of wind direction or shadows, such as between fence lines, also deprives the team of most of its capability. When working on a post where the handler must focus on tasks other than working the dog, the dog's abilities, other than protecting his handler, are largely wasted. Finally, a handler usually is unable to quickly or effectively use his or her weapon because the handler also must control the dog. Therefore, a patrol dog team should not be used on a post where rapid, effective firepower is essential.

2-20. Post selection

In selecting security posts, select those posts where it is possible to maximize the advantages to be gained by using patrol dog teams, while minimizing the factors which tend to reduce the dog's capabilities. The area should be as free as possible of distractions that tend to confuse the dog or discourage it from reacting to changes in its environment. Planners must consider the location and size of the area to be protected, the condition and type of terrain, and the prevailing wind direction. All these factors are used to determine the number of dog teams and where the teams will be

generally located. Where there are several limiting factors, adjust the size, number, and locations of the posts to compensate for any potential losses of team effectiveness.

2-21. Perimeter and distant support posts

Patrol dog teams are especially useful for perimeter and distant support posts because they are usually located well away from normal activity and large numbers of people. These posts also usually enclose large areas, and it would take a large number of single sentries to secure the area effectively. The large size of these areas allows the dog team to change positions to take best advantage of the prevailing wind direction. These posts may be secured only during periods of advanced security and high threat. Occasional random posting of these areas is recommended, especially during periods of low visibility such as darkness, rain, and fog. Barriers and obstacles, such as fences, buildings, gullies, and streams also must be identified and considered in security post planning. Place the dog team so that these obstacles offer the least interference to security.

2-22. Close boundary (CB) posts

CB posts differ from perimeter and distant support posts in that it is closer to and dedicated to protecting specific resources. The reasons for using patrol dog teams for security are the same. The post is slightly different because the team is closer to the resource and cannot move around as much to work the wind. CB posts also are closer to human activity and other distractions, such as engine noise and petroleum, oil, and lubricant (POL) odors. These distractions may require setting up a different post location and post limits for a dog team than those for a lone sentry on the same post.

a. One of the decisions that most directly influences security is whether to post the team inside or outside the fence surrounding the resources to be protected.

(1) If placed inside a fence, the team can patrol close to and periodically check the resources. But, if the dog detects an intruder trying to enter the area, the fence may prevent the team from following the escaping intruder. Also, a decoy placed upwind of a dog team confined by a fence can distract the dog while other intruders penetrate the area downwind.

(2) If placed outside a fence, a patrol dog team can move around easier to work the wind and can more easily follow and respond to the source. However, the team cannot respond quickly to a problem inside the protected area. Also, a decoy placed upwind from the team can draw the team away from the resource and make it easier for others to attack from downwind.

b. The more a team's ability to work the wind is limited, the more the team must rely on sound and sight for detection. Planners must learn how environmental change affects a dog's ability to see, hear, and smell, so post locations and limits can be adjusted. Flexible posting also increases deterrence by allowing the team to avoid a set patrol pattern.

c. Using a patrol dog team in a lighted area makes it easier for an outsider to detect the team's presence, allows potential intruders to observe the team's movements, and increases the possibility of a successful penetration. The lights also may cause the dog to rely more on sight than on its other senses. Therefore, if the team must be used in a lighted area, it should be allowed to patrol a varied route, remain in shadows, or stand stationary in concealed downwind positions.

2-23. External intrusion detection systems (IDS)

Continuing development and use of IDS for security makes it necessary to reassess the role of patrol dog teams in security of priority resources where an IDS is used. Although IDS are designed to greatly reduce the probability of a successful area penetration, they are not designed to totally replace sentries or dog teams. IDS cannot "see" beyond the outer clear zones, cannot counter intrusions, cannot track the progress of an intruder force after penetration, and are subject to malfunction and breakdown. Patrol dog teams or sentries cannot counter all potential problems, but they can be used selectively to counter some of the IDS limitations. Security planners should develop plans which set an effective balance between sensor systems and dog teams. Some suggested functions for integrating dog teams into IDS-augmented security systems are as follows:

a. Patrol dog teams may be used inside or outside IDS-protected areas to give immediate response to areas not clearly seen by closed circuit television (CCTV), or to support security response teams in their role of alarm assessment.

(1) Inside protected areas, patrol dog teams may track hidden intruders from point of penetration to their hiding location.

(2) Patrol dog teams may be posted outside IDS-protected areas during periods of increased threat to expand the protected area beyond the range of the IDS. This use is particularly desirable when there is heavy vegetation beyond the perimeter clear zone, or when protected areas are located on or near installation perimeters and may, therefore, be easily accessible to the public.

b. A patrol dog team works effectively as an element of the security response team, or as an element of other designated response forces (RFs).

c. Patrol dog teams can be used to compensate for decreased IDS effectiveness when poor visibility or other environmental conditions adversely affect the IDS equipment or when IDS is not functioning.

2-24. Mobile security patrols

The patrol dog team's training is especially useful for mobile patrols and RFs. As an individual patrol, a patrol dog team can cover individual areas or several areas, and can respond to incidents occurring in any area.

a. Individual mobile patrol duties may include alarm response, building checks, area surveillance and patrol, and identifying and apprehending intruders. Dog teams on mobile patrol can cover large areas quickly, and present both a physical and psychological deterrent.

b. When responding to a request for assistance, the handler must be given the precise location of the incident and whether the intruder is located inside or outside the protected area. If wind direction can be determined, the handler can plan his or her approach to the area from the downwind side. When the patrol dog team arrives, the personnel on the scene should point out the location of the suspected intruder and give the handler any other related information. While the patrol dog team closes on the intruder, other responding forces should follow or provide cover for the team.

c. Patrol dog teams check buildings in their patrol area to detect anyone using the building as concealment or to detect personnel who have entered a building illegally.

(1) The patrol dog team always approaches the building from downwind and checks the entire outside of the building first. This includes checks of any storage sheds, trash containers, and other possible hiding places. As the team circles the building, the handler physically checks doors and windows for signs of forced entry.

(2) If a handler finds an unsecured building, the handler should report the situation immediately and request a backup patrol before entering to search the building. While waiting for the backup patrol to arrive, the handler should locate himself or herself to be able to observe or allow the patrol dog to detect any person attempting to leave the building. An intruder may not leave the building the same way he or she entered but often will choose an exit that allows the least chance of detection.

(3) When the backup patrol arrives, the handler should discuss the building search method and locate the backup patrol in areas where they can best support the dog team. The area around the apparent point of entry should be kept clear until after the building has been searched or processed for any evidence by investigators.

(4) The handler decides whether to conduct the search on- or off-leash considering the dog's ability to work effectively off-leash, the type and size of building, the time of day or night, indications of forced entry, known or suspected contents of the building, and the possibility of innocent persons being inside. The handler should carefully select the best point of entry into the building, if there is a choice.

(5) Backup patrol personnel should select positions from which they can observe all possible exits from the building and any vehicles parked nearby. They should also be alert for any other personnel moving about the area.

(6) When all personnel are in position, the dog team prepares to enter the building. The handler must announce to anyone inside the building that a trained patrol dog is entering to search the building and give anyone inside a reasonable opportunity to exit. After an appropriate length of time, the patrol dog team enters and searches the building. Even if an intruder comes out or is found, the patrol dog team should always search and clear the entire building in case there are more intruders.

(7) The handler should allow the patrol dog to enter the building first to clear the immediate area of entry before the handler enters. All rooms and areas inside the building should be entered by the dog first. As the search progresses, some lights may be turned on to areas that were cleared but no light that would silhouette the team should be turned on at any time.

(8) If the dog responds, the handler should take cover, recall the dog, and put the dog on-leash. The handler then calls to the intruder to come out with hands raised or the dog will be released to attack. The handler also should notify his backup that one or more intruders have been located. Help in making the apprehensions should be requested if necessary.

(9) If the dog does not respond and the building is cleared, the team should attempt to track away from the point of forced entry. Tracking may result in discovering the method of escape, discarded evidence, or finding the intruder.

d. As a member of a response team, a patrol dog team increases the response team's capability to find and apprehend suspects. The response team needs to frequently train and operate with the patrol dog team so that all actions are coordinated and predictable. A variety of response training exercises develop the ability of the team to work well together. The dog team should be the active member of the response team during all searches.

2-25. Secondary response forces

RFs are typically used as blocking forces and for sweeps and counterattacks. Patrol dog teams can greatly improve the capabilities of the RF. Some factors which must be considered are:

a. When used with blocking forces, blocking positions must be selected downwind from the dog team's position.

b. When used for sweeps, the RF moves into the wind with the dog team in the lead position.

c. In preparing for counterattacks, a dog team can often pinpoint the exact location of individual intruders.

d. In clearing a position that has been counterattacked successfully, a dog team can help locate and catch hidden intruders. EDDs can be used to help clear the area of explosive charges, weapons, and ammunition.

Section IV

Employment of Patrol Dogs—Combat Support Operations

2–26. General mission

In combat support operations, patrol dog teams are used to enhance the detection capabilities of the combat support force, and to provide a psychological deterrent to hostile intrusions. In a hostile environment, a dog's response will, in many cases, provide the initial warning to the presence of a hostile force if the teams are properly located. In past combat operations, MWD teams often provided warning of attacks early enough to allow RFs time to deploy into advantageous positions and prevent enemy forces from reaching their objectives. MWD teams also have helped to clear protected areas of hostile persons, explosives, and weapons after attacks.

2–27. Area defense

Areas that cannot be covered by static defensive posts because of vegetation, terrain, or some other peculiar feature can be secured by using patrol dog teams. The patrol dog can detect personnel using concealed avenues of approach and provide an early warning to defenders. Each dog team's area of responsibility should be large enough so that the team can move to take advantage of the prevailing wind directions. A fixed sentry position should be established to provide covering fires for each dog team in case the team must withdraw closer to the defensive perimeter after the dog has responded on an attempted hostile probe or penetration.

2–28. Warning and response procedures

Several procedures should be developed for warning friendly forces of a patrol dog's response because circumstances may prevent the use of a radio. Also, different types of responses tailored to fit a variety of potential situations should be developed. For example, it may be desirable to have the dog team follow the response and locate the cause. At other times, combat intelligence may require that the team maintain in the alert position until assistance arrives, or to withdraw to a more advantageous position. Whatever response is used, the handler should not release a dog unless it is necessary to defend:

- a. Himself or herself.
- b. Other personnel.
- c. Protected resources.

2–29. Listening posts, reconnaissance, and combat patrols

a. *Planning factors.* When setting up listening posts or combat patrols, consider the availability and suitability of patrol dogs for the particular mission. The kennelmaster must be briefed early regarding the mission. This will ensure that the most suitable patrol dog team can be selected and the handler can prepare for the mission. The handler should check the dog for any limiting ailments and conduct training rehearsals to become familiar with the mission. The kennelmaster and selected handler(s) must be involved in planning conferences and briefings involving the use of a dog team.

(1) In defensive operations, combat patrols are used to provide early warning, to confirm intelligence information, and detect or deter enemy action. Patrol dog teams greatly enhance the security of reconnaissance and combat patrols.

(2) On combat patrols, a patrol dog works at maximum efficiency for only two or three hours. The team is most effective in uninhabited areas. If a dog frequently responds on friendly forces and is continuously taken off response, the dog soon loses interest and reliability. Therefore, handlers must train to be able to perform these missions. Only the best teams should be selected.

(3) Patrol leaders and members must be briefed on actions to take if a dog handler is seriously wounded or killed. Patrol dogs that have worked closely with patrol members and have developed tolerance for one or more of them, will usually allow one of the patrol members to return it to the kennel area. However, the dog may refuse to allow anyone near its handler, and other handlers may need to be called for help.

b. *Listening posts.* On a listening post, the dog team (along with another soldier) should be positioned in the forward area of the tactical area to reduce distractions to the dog, yet close enough to maintain contact with friendly forces. In selecting a location, consider the primary detection senses of the dog. Whenever possible, MWD team listening posts should be located downwind from any potential enemy position or avenue of approach. Other locations force the dog to rely on its hearing and sight for detection. However, any advance warning the dog gives can be of benefit to friendly forces.

c. *Reconnaissance patrols.* Reconnaissance patrols may obtain information about the number, weaponry, and movements of enemy forces.

(1) Patrol dog teams used with reconnaissance patrols during daylight or darkness help by detecting enemy presence, helping the patrol to avoid discovery, and locating enemy outposts. In the past, some patrol dog teams also have been

trained to detect mines and booby traps. When the dog responds, the handler should signal the patrol to halt until the cause of the response can be identified and the patrol can proceed safely.

(2) If a fire fight develops while the patrol dog team is at the point position, the dog team should respond to fire team directions and act as a regular member of the patrol.

(3) Generally, the best locations for dog teams are directly in front of the patrol or on its flanks. Prevailing wind direction should be used to improve the patrol's chances for early warning of enemy forces. The handler must concentrate on the dog to read its response and will not be able to use a weapon rapidly. Therefore, a member of the patrol should be assigned to protect the dog team. If the wind direction is from the rear of the patrol, the dog is forced to rely on sight and sound and may not be as effective.

d. Combat patrols. The most common combat patrol using patrol dog teams is the ambush patrol. A dog team should be placed in front of the patrol to minimize distractions, yet close enough to maintain contact with other patrol members. Patrol dogs on ambush patrols must remain silent and not respond aggressively to approaching enemy forces.

2-30. Enemy prisoner of war (EPW) operations

In EPW operations, patrol dog teams are used for camp perimeter security to guard against escape. The dog's keen sense of sight, smell, and hearing assists the handler and camp authorities in detecting unauthorized activity. Their presence also acts as a deterrent to such activity. The team can be used to guard prisoners while in transit, and assist in the search for escaped prisoners.

2-31. Mobilization and deployment

a. Deployment preparations. All levels of command need to be involved in the deployment preparations for MWD teams. Plans for deployment, and for the actions to be taken after arriving at the deployment destination, must include the following:

- (1) Considerations of equipment requirements.
- (2) Use of field kennels.
- (3) Orientation training (including safety procedures).
- (4) The concepts of operations to be used.

b. Planning for deployment. Deployment plans must include coordination with the supporting military veterinarian, consideration of the expected duration of the deployment, and consideration of the types of facilities which may or may not exist at the deployment destination.

(1) Dogs must receive proper care during deployment and upon arrival at the destination. Care must be taken to be sure the dog does not overheat or freeze, or suffer from lack of food, water, or rest.

(2) Army mobility requirements necessitate that all MWD teams have a shipping crate. The shipping crates, when used to transport dogs even over short distances, simplify handling, loading, and transporting, and give the dogs adequate space and ventilation during shipment. In addition, the shipping crates may be needed for use as temporary kennels at intermediate sites or at the deployment destination. Standard metal dog crates occupy 31 cubic feet.

(3) Water requirements for dogs usually average about 10 gallons a day for each dog team.

(4) Enough dog food must be taken to last 30 days or until resupply can be established. Determination of type dog food and contents of first aid kits (that must go with the dog teams) should be made by the supporting veterinarian. Information on the deployment destination, climate, and terrain help to determine the specific contents of the first aid kits. For example, if dogs will be employed on rough terrain, a "pad toughener" is included in the first aid kit.

c. Equipment used. Required equipment must travel with and arrive with the patrol dog team(s) so they can be fully operational as quickly as possible. The following equipment should be available for dog teams identified for deployment:

- (1) *Dog equipment (one per dog).*
 - (a) Dog handler gear (two sets).
 - (b) Dog food (30-day supply).
 - (c) Water bucket (plus one spare for every five dogs).
 - (d) Feed pans (plus one spare for every five dogs).
 - (e) Shipping crate.
 - (f) Jerry cans, water type (two per day).
 - (g) Poncho (for use with the dog).
- (2) *Personnel equipment (one per handler).*
 - (a) Flashlight.
 - (b) Fatigues (three pair).
 - (c) Combat boots (two pair).
 - (d) Foul weather gear.
 - (e) Shelter half (two).
 - (f) Snake bite kit.

- (g) Field mess kit.
- (h) Sleeping bag.
- (i) Web belt.
- (j) Rope.
- (k) Canteens (three).
- (l) Other equipment as required by unit standard operating procedures (SOPs).
- (3) *Other equipment.*
 - (a) Axes.
 - (b) Shovels and rakes.
 - (c) Copies of AR 190–12, DA Pam 190–12, and other appropriate references.
 - (d) Hatchets.
 - (e) First aid kit.
 - (f) Brooms, mops, brushes, disinfectant.
 - (g) Arm protector (attack sleeve).
 - (h) 50-gallon trash can.
 - (i) Refrigerator for veterinary medical supplies.
 - (j) Power generator.
 - (k) Other equipment as required by unit SOPs.

d. *Field kennels and support facilities.* A suitable kennel site must be carefully selected. Before deployment, some possible locations may be selected from a map. However, as soon as possible after arrival, the sites should be inspected to choose the most suitable location.

(1) When selecting a site, consult a veterinarian whenever possible about possible health hazards. Location of the kennel in a congested area may be necessary to protect the kennels from enemy attack. A temporary screen or fence may be needed to block the dog's sight, so the dogs will be able to rest.

(2) When shipping crates are used as temporary kennels, the crate should be turned upside down and raised four to six inches off the ground to allow for adequate drainage and reduce parasite breeding places. Place modified pallets in the crates to prevent the dogs from injuring feet or legs in the crate air holes. In hot climates, place crates under trees, tarpaulin, or plywood to provide shade and ventilation. Spread gravel, if available, around and under the crates to allow for drainage and easy removal of solid waste.

(3) A large tent or prefabricated building can serve as a temporary storage location for equipment, rations, and other supplies. A second tent or building erected at the kennel site to house handlers and the kennelmaster provides the kennel with sufficient manpower for security of the kennel area.

(4) Although conditions around a temporary kennel may never be ideal, a high standard of sanitation is essential to prevent diseases and parasite infections.

e. *Orientation training.* As soon as possible after arriving at the deployment destination, and while making sure that site security is established, orientation training must begin. Orientation training allows the MWD teams to quickly develop familiarity with their new location and to quickly develop an understanding of their missions. The kennelmaster needs to evaluate or reevaluate the degree of skill of each of the MWD teams so they are fully prepared to support the deployed force. Initial evaluation and training should consist primarily of field problems, attack, search, reattack, tracking, and basic obedience. The remainder of the orientation period should be devoted to training on patrol, squad, and fire team exercises. Field problems should include combat and reconnaissance patrols, outpost, listening post, ambush patrol, sweep deployment, and tracking. Training should also include the handler firing his assigned weapon while maintaining control of the dog. Some training should be done at dusk, and then in darkness, so that the handler may see (for safety), and the dog may adjust to the noise and flash of weapons. Most MWD team missions can be expected to occur at night.

Section V

Employment of Narcotics Detector Dogs

2–32. The drug problem

The abuse of drugs by military personnel, their family members, and civilians, who may enter military areas for work, business, or recreation, presents a continuing problem for the Army. Every effort must be made to reduce the potential danger to society and particularly to the military community from those who sell or abuse drugs.

2–33. The narcotics detector dog

One of the most efficient means of detecting the possession or transportation of dangerous drug contraband is the well-trained narcotics detector dog. The narcotics detector dog is trained through a program of practice and reward to recognize the scent of certain drugs, such as marihuana, hashish, heroin, cocaine, and other related substances. When the narcotics detector dog locates any of these substances, the dog will alert its handler. Most of the Army's narcotics

detector dogs are also patrol dog qualified and are commonly referred to as patrol/narcotics detector dogs. Some large and small breed narcotics detector dogs are not patrol trained. They are called narcotics/contraband detector dogs or contraband dogs. (These dogs are being phased out of the inventory through attrition and are being replaced by the patrol/narcotics detector dog.) Regardless of the label, all these dogs perform a valuable service by helping to rid the military community of illegal drugs and the problems associated with drug and controlled substance abuse.

2-34. Legal aspects—narcotics detector dog teams

There are several legal considerations in using the narcotics detector dog since the apprehension and possible criminal prosecution of offenders may be involved.

a. The use of narcotics detector dogs during an inspection must be authorized by the installation commander or a commander having control over the personnel and property to be inspected. This applies to all inspections, including buildings, vehicles, aircraft, and so forth.

b. If, during the course of an inspection, a narcotics detector dog responds, the dog's actions may be sufficient in the case of persons to justify apprehension and a search. In the case of property, the response may be sufficient to establish probable cause to obtain authorization to search. In order to establish probable cause, a description of the dog's conduct, training, and experience must be conveyed to the authorizing official to permit that person to assess the reliability of the dog. To ensure that this information is available, the following will be maintained for each detector dog:

(1) A general record of the training and experience of the narcotics detector dog team is maintained on DA Form 2807-R (Military Working Dog Training and Utilization Record). (See para 3-34.) This form is prescribed in AR 190-12.

(2) A detailed record of training and experience showing the numbers of training and actual narcotics detection operations in which the narcotics detector dog team has been involved and the dog's performance record is maintained on DA Form 3992-R (Narcotics or Explosives Detector Dog Training and Utilization Record). (See para 3-35.) This form is prescribed in AR 190-12.

c. A demonstration of the narcotics detector dog's proficiency may be required. It should include training aid plants of each type of substance the dog has been trained to detect and a test of the dog's ability to respond on places where a drug has been recently concealed and then removed. This demonstration also may help establish the narcotics detector dog team as a reliable source of information for the commander. The test of the dog's ability to detect recently abandoned hiding places for the drugs or clothes that have the smell of drugs is important because it helps to explain the dog's response when no drug can be found, and reinforces the dog team's credibility.

d. The records described in para b, above, should be carried by the handler when the narcotics detector dog team is TDY for narcotics detection operations so the records are available to appropriate commanders at the TDY site. Commanders at the site should review these records and observe a demonstration before authorizing drug detection operations.

e. Commanders and supervisors should work closely with the command SJA to ensure that drug detection operations achieve objectives and comply with legal requirements. Court decisions and changes to existing laws and policy frequently alter the methods and procedures which must be followed for proper narcotics detection programs. Handlers must learn and apply the rules of evidence, search and seizure, and the procedures for collecting and preserving evidence.

f. Although the dog's training and utilization record and demonstrated proficiency are important to establishing credibility, omissions or irregularities will not necessarily prevent a valid authorization to search. As a basis for authorizing a search, an officer otherwise eligible to do so must be reasonably satisfied that the dog is reliable. This belief must be based on reasonable grounds. Those grounds may be reviewed in court. Whether information is enough to warrant faith in the dog's reliability is a matter of judgment based on facts rather than on compliance with the recommended procedures.

2-35. Certification and decertification

a. After the initial certification of a narcotics detector dog at the 341st Military Working Dog Training Squadron, recertification is required under any of the following circumstances:

(1) When a new handler is assigned to the dog. Any recertification with a new handler automatically nullifies any certification with any other handler. Dog team assignments always will be made consistent with the principle of one dog—one handler, and only certified narcotics detector dog handlers may be assigned to handle narcotics detector dogs. Only one handler will be assigned to each dog.

(2) When a dog team's proficiency training has been interrupted for 30 or more consecutive days for any reason, full recertification of the team by a certification authority (AR 190-12) is required.

(3) When a narcotics detector dog team fails to maintain the minimum proficiency standard of 90 percent or better detection for three or more consecutive months.

(4) Full or partial recertification may be required any time the installation commander, PM, security officer, or MP commander has reason to doubt the team's reliability.

b. To maintain the narcotics detector dog's proficiency during a handler's extended absence, at least four hours of proficiency training must be conducted each week. This is performed by the kennelmaster, a dog trainer, or a qualified narcotics detector dog handler.

c. If a narcotics dog is not able to continue detector duties, fails recertification, and retraining fails to correct the situation within 45 days, the circumstances will be thoroughly documented. Documentation will include the following:

(1) The apparent cause of failure.

(2) A statement from the supporting veterinarian identifying any physical or medical conditions which may be contributing to or causing the failure.

(3) A summary statement of retraining efforts to include MACOM or Army training assistance team's efforts to correct the deficiency.

d. The complete documentation package will be submitted through the appropriate MACOM to HQDA, ODCSOPS (DAMO-ODL-S), requesting further instructions. ODCSOPS (DAMO-ODL-S) will review and forward the request to the 341st Military Working Dog Training Squadron for appropriate disposition instructions.

e. If the dog is permanently decertified, the unit will report decertification by letter to the 341st Military Working Dog Training Squadron so the dog's NSN can be changed. Unit records also will be changed.

(1) If the unit where the dog is assigned can use the dog as a patrol dog, the unit should reassign the dog to a patrol dog handler. The unit should then request a replacement narcotics detector dog by submitting a MILSTRIP requisition according to AR 190-12. Any outstanding MILSTRIP requisition for a patrol dog will be canceled.

(2) If the unit has no patrol dog requirement, the unit will report the dog as excess to requirements in accordance with AR 190-12. A replacement narcotics detector dog will be requisitioned in accordance with AR 190-12.

Section VI

Employment of Explosives Detector Dogs

2-36. The need for explosives detector dogs

Few other criminal acts create such concern and fear in the hearts of a nation's citizens as a series of bombings. It is no coincidence that organized crime and terrorist groups routinely utilize explosive materials as a means of achieving their violent goals. Whether the objective is murder, intimidation, extortion, or governmental disruption, the bomb is a favorite and very effective weapon of the criminal element. One of the most effective countermeasures to the use of explosives is the deterrent value and the detection capabilities of the EDD team.

2-37. The explosives detector dog team

EDD teams fill three distinct roles in MP operations (in addition to the routine use of patrol dog teams.)

a. *Deterrent.* Public knowledge that EDD teams are assigned to and are used at an installation acts as a deterrent to persons who may try to use explosives illegally on the installation. The knowledge that explosives can be detected by EDDs at installation gates or in places where explosives have been hidden, can prevent a person from attempting to bring explosives on to an installation.

b. *Search.* The most common use of EDD teams, and probably the most important, is to search areas of buildings against which a bomb threat has been made. A well-trained EDD team can conduct a significantly more effective search of any area or facility in far shorter time than almost any number of people. Using EDD teams also helps to reduce the potential risk to persons who would otherwise have to do the search without benefit of the dog's superior sense of smell.

c. *Investigation.* EDD teams can be useful in many investigations involving almost any type of weapon, ammunition, or explosives. They are particularly useful if there is a need to locate one or more items which may have been hidden in an area.

2-38. Legal aspects—explosives detector dog teams

The most frequent tasks performed by EDD teams are in response to bomb threats against military or civilian resources. The general requirements for providing EDD team support to civil authorities are stated in AR 190-12. However, many units also are using EDD teams in random searches at entry control points, for inspection of troop and dependent housing areas, for checking aircraft and aircraft areas, for sensitive or high-value equipment storage area checks, or for checks of mail, baggage, freight shipments, and so forth. The expanded use of EDD for these functions presents many of the same legal problems for explosives searches that are characteristic of narcotics detector dog team searches for drugs. Whenever the operational situation may result in the apprehension and possible criminal prosecution of offenders, the procedural and record-keeping requirements defined in para 2-33 for narcotics detector dogs apply to EDDs. However, compliance with procedural requirements should never be an obstacle to protecting life and property. The EDD handler should always be prepared to establish the EDD team's credibility with training, utilization, and proficiency records, and/or a demonstration.

2-39. Certification and decertification

a. EDDs and handlers initially are certified upon successful completion of training by the 341st Military Working Dog Training Squadron. The continuing effectiveness of EDDs depends on continual reinforcement of the detection ability through proficiency training. Proficiency training is mandatory, and an EDD team should receive at least four hours training each week. The minimum standard to maintain certification as an EDD team is 95 percent or better detection. Failure to maintain an average proficiency that meets or exceeds the minimum standard for three or more consecutive months will result in automatic decertification of the MWD team. The team may be recertified only after retraining and consistent demonstration of the minimum standard of proficiency to an appointed certification authority or to the instructor staff of the 341st Military Working Dog Training Squadron.

b. After the initial certification of an EDD and handler at the 341st Military Working Dog Training Squadron, recertification of the EDD is required under any of the following circumstances:

(1) When a new handler is assigned to the dog. Any recertification with a new handler automatically nullifies any certification of the dog with any other handler. Dog team assignments always will be made consistent with the principle of one dog—one handler. Only certified EDD handlers may be assigned to handle EDDs. Only one handler will be assigned to each dog.

(2) When a dog team's proficiency training has been interrupted for 30 or more consecutive days for any reason, full recertification of the team is required.

(3) When an EDD team fails to maintain the minimum proficiency standard of 95 percent or better detection for three or more consecutive months.

(4) Full or partial recertification may be required any time the installation commander, PM, security officer, or MP commander has reason to doubt the team's reliability.

c. To maintain the EDDs proficiency during a handler's extended absence, at least four hours of proficiency training (in addition to four hours of patrol training) for the dog must be conducted each week by the kennelmaster, a dog trainer, or a qualified EDD handler.

d. If an EDD is not able to continue detector duties for any reason, or fails recertification, and concentrated retraining fails to correct the situation within 45 days, the circumstances will be thoroughly documented. Documentation will include:

(1) The apparent cause of failure.

(2) A statement from the supporting veterinarian identifying any physical or medical conditions which may cause the failure.

(3) A summary statement of retraining efforts to include MACOM or Army training assistance teams' efforts to correct the deficiency.

e. The complete documentation package will be submitted through the appropriate MACOM to HQDA, ODCSOPS (DAMO-ODL-S), requesting further instructions. Based on the documentation package, certification authority recommendations and status of Army-wide MWD program, the HQDA, ODCSOPS(DAMO-ODL-S), will review and forward to the 341st Military Working Dog Training Squadron who will advise:

(1) To continue retraining efforts.

(2) To decertify the dog.

(3) To ship the dog to the 341st Military Working Dog Training Squadron for evaluation.

f. If the dog is permanently decertified, the unit will report the matter by letter to the 341st Military Working Dog Training Squadron so that the dog's NSN can be changed. Unit property records will also be changed.

(1) If the unit where the dog is assigned can use the dog as a patrol dog, the unit should reassign the dog to a patrol dog handler and request a replacement EDD by submitting a MILSTRIP requisition as prescribed by AR 190-12. Any outstanding MILSTRIP requisition for a patrol dog will be cancelled.

(2) If the unit has no patrol dog requirement, the unit will report the dog as excess to requirements in accordance with AR 190-12. A replacement EDD will be requisitioned as prescribed by AR 190-12.

2-40. Bomb threat planning

Army guidance on bomb threat planning and procedures is contained in Training Circular (TC) 19-5. Each unit or activity on an installation should have a bomb threat search and evacuation plan that describes the actions taken when a bomb threat is received. When EDD teams are available, the use of these teams should be included in these plans.

2-41. Response to bomb threats

a. The procedures provided here as guidance should be used during both actual bomb threats and training rehearsals for bomb threats. Training on bomb threat responses can:

(1) Be used to enhance the proficiency of EDD teams.

(2) Train security and unit personnel on actions which can and cannot be taken when searching for explosive devices.

(3) Educate security and unit personnel on search precautions when the EDD team is not available.

b. The type of threat received and local policy determine the initial actions to be taken in response to a bomb threat. Evacuation of the area may or may not be ordered by the responsible commander. The area must be evacuated if the EDD team is being used to perform the initial search. The advantage of using the EDD team to conduct the first search is that the EDD handler has specialized knowledge of explosives and explosive devices and search techniques. The area must be evacuated to minimize the distractions to the EDD team and to reduce the risk to area occupants in the event of an explosives detonation. Whether the building is evacuated or not, a complete and thorough search of the area must be made by residents or users of the facility, with the assistance of safety and security personnel (MP, fire fighters, explosive ordnance disposal (EOD) teams, and others as prescribed by local policy), as appropriate. In conducting an explosives search with an EDD team, the following basic precautions should be taken in addition to the search procedures described in TC 19-5:

(1) The EDD handler should determine the number of safety and security personnel who will be allowed to accompany the EDD team into the area to be searched. Each of the personnel selected should be briefed on the actions to be taken during the search and in the event the dog responds.

(2) The EDD handler and any personnel designated to accompany the team during the search should be provided protective equipment and other items necessary to conduct a safe and thorough search. These would include flak vests, special flashlights such as the ones issued for use in coal mines, and inspection mirrors.

(3) The search should be as thorough as possible. However, nothing should be moved or disturbed unless it can be positively ruled out as an explosive device. Improvised explosive devices (IED) or homemade bombs, can be triggered in an almost infinite number of ways. Methods include lifting, tilting, pushing, pulling, or other movements, as well as sound, light, heat, and by remote control. IEDs can be disguised to look like anything from a desk pen, telephone, coffee pot, or trash can to a chair, table, door, fire extinguisher, movie projector, or briefcase. No object can be automatically ruled out. The EDD team should inspect every item that cannot be positively identified.

(4) Searchers should not change or move anything during the search. If lights or other electrical or mechanical appliances are on, leave them on; if they are off, leave them off until a thorough search is completed. An IED can be triggered by the application or removal of light or power.

(5) After the EDD search team is able to clear an area, section, or building, persons assigned to the area should also search, when it is possible to enter the area without distracting the EDD. Persons assigned to the area or building are most familiar with the contents and are probably best qualified to identify equipment which is out of place or which does not belong, as well as areas where a potential explosive device could be successfully hidden. Special care should be taken to search areas accessible to the general public such as the building exterior, entrances, corridors, stairways, storage and utility closets, and rest rooms. Be particularly cautious of and report any object that appears out of place or unusual.

(6) Searches of locked rooms can usually be left until open room searches have been completed. If, however, examination of the door and lock reveals evidence of forced entry, the room should be searched immediately. Before entering such a room, carefully examine the door for any indication that the door is wired as a triggering device.

(7) If the person making the bomb threat gave a specific time for the bomb to go off, the area should be evacuated of all personnel, to include search personnel, during an appropriate time frame surrounding the threatened time of detonation. All personnel being evacuated should be moved to an area at least 300 feet from the building or area in which the explosive device is allegedly planted. Whenever possible, personnel should be kept clear of an evacuated area for at least one hour past the threatened detonation time.

(8) During the conduct of the search, training aids such as C-4 plastic explosive, military dynamite, or smokeless powder should be planted periodically so the dog can find them. This helps the dog to maintain interest in the search. Training aids should only be planted in areas that already have been searched by the EDD team. During an actual search, the EDD should be allowed to find a training aid every 15 to 30 minutes to break the search routine and reward the dog for its perseverance. A skilled EDD handler will know the proper interval between training aid finds to maintain the dog's interest.

2-42. Positive responses

When the EDD shows increased interest in or responds on an object, the handler must reward the dog and report the response to the appropriate commander or supervisor. The handler should not touch or retrieve the suspected object during an actual search or training exercise, nor should the handler allow the dog to scratch or paw at the object or pick it up in its mouth. If the dog responds during an actual search, immediately notify EOD personnel of the location of the response. EOD will dispose of any suspect devices or objects. Neither the MPs nor any other person should ever attempt to move, open, or tamper with any object suspected of being an explosive device unless they have been specifically trained to do so.

2-43. Alternative immediate action

A situation may arise when EOD personnel are either not available or cannot respond immediately and, because of the location of the explosive device, immediate action must be taken to neutralize or limit the effects of the explosion. In some cases, barricades of sandbags, mattresses, or other nonfragmenting material may be erected around the device to partially contain or redirect the blast. Such efforts, however, greatly increase the exposure and attendant risk of

personnel to an explosion. Therefore, any immediate protective action should only be taken in cases of extreme necessity. Regardless of the circumstances, the area should always be evacuated of all personnel in advance of any time of threatened detonation. Only EOD personnel should be allowed to reenter the area to clear the explosives device.

Section VII

Reporting Use of Military Working Dogs

2-44. Incident reporting

The MP has known for several years, now, the valuable contribution made by MWD teams to the detection, investigation, or solving of several types of criminal activity. However, the ability to identify or document those completed cases or incidents that could both clearly identify how we use dog teams as well as demonstrate their value to MP and Army missions has been limited. As a result, supplementary crime codes have been developed for entry on DA Form 3975 (Military Police Report). The supplementary codes identify the incidents reported on MP reports which have involved the use of patrol dog teams, narcotics detector dog teams, and/or EDD teams. There are separate codes for each type of dog team as well as separate codes for detection of marihuana, hashish, heroin, and cocaine by narcotics detector dog teams. These supplementary codes are prescribed in AR 190-45.

2-44.1.

Not used.

Chapter 3

Training

Section I

Proficiency Training

3-1. General

a. The purpose of this chapter is to provide performance standards for the MWD team. This chapter is not intended to serve as a training manual, although some training methods will be presented. Specifically, this chapter:

- (1) Describes how to conduct proficiency training.
- (2) Identifies the tasks that dogs and handlers are school-trained to do.
- (3) Prescribes the tasks that MWD teams must be taught to be operationally proficient.
- (4) Prescribes the minimum standards for each of the tasks.
- (5) Explains the methods to be used to evaluate the proficiency of an MWD team.

b. Dogs and handlers who have been certified by the 341st Military Working Dog Training Squadron have demonstrated the proficiency level required for certification (that is, explosive detector has met 95 percent detection standard and narcotics detector has met 90 percent standard). This is not an assurance of their ability to perform these tasks to the same degree of proficiency in the working environment. Therefore, each MWD team assigned to a unit or installation should be evaluated locally on each of the tasks and on their general ability to perform MP missions as a team in the working environment. Additional training will normally be necessary before new MWDs and handlers, as a team, can consistently achieve all of the performance standards and perform the full range of MP missions.

c. In addition to the initial evaluation, each MWD team should be evaluated periodically by the PM or unit commander to be sure proficiency is maintained. All MWD team evaluations, whether initial or routine, must be done in an environment that simulates the working environment as closely as possible. The purpose of the evaluation must be to identify deficiencies and the corrective measures necessary to raise the MWD team's proficiency level to at least the minimum standards. An MWD team should be able to consistently meet at least minimum proficiency standards before being employed for operational MP missions. A written record of this evaluation will be maintained with the dog's training record.

3-2. The need for training

MWD teams need continual proficiency training to maintain their skills. The team's normal day-to-day duties do not provide the necessary practice in all of the skills a team has been trained to do. Without frequent reward reinforcement for performing a task correctly, the dog will soon lose interest in performing the task. Likewise, the handler who does not practice his or her skill loses the ability to "read" the dog's responses. Proficiency training, then, maintains all of the dog team's basic skills and improves the team's performance.

3-3. The principles of training

a. There is no magic formula or singular method for training MWDs. Each dog has unique characteristics and training must be adapted so that a consistently correct response is achieved. The basic principle of dog training is that

the dog is taught to associate a pleasant event with the correct performance of the required task. This association is brought about in training by applying knowledge, patience, repetition, praise, reward, and correction.

(1) When training the dog, the handler must apply all the knowledge he or she gained about dog training while being trained as a handler at the school, as well as drawing on the knowledge of other handlers, kennelmasters, and dog trainers. A handler's education must not stop when leaving the handler school. The handler must take advantage of every opportunity available to learn more about handling and training dogs.

(2) Patience is the steadiness, endurance, or perseverance necessary to help the dog develop the skill to perform a task correctly. A handler must remain calm and self-controlled while working with the dog on each task.

(3) Repetition is practicing the same exercise or task several times until the desired or correct response is achieved consistently.

(4) Praise is probably the most important reinforcement. Praise must be given at the precise moment the dog makes the desired or correct response. Praise encourages the dog to perform a task correctly. Praising a dog too early or too late may only confuse the dog about the nature of the task the handler is trying to train the dog to do.

(5) A reward is a specific object, such as food, a ball, or other favorite play object, that is used to recognize the dog for successful and proper completion of a task. To maintain the strength or value of the reward, the following principles apply:

(a) The dog must never get too much of the reward so that it no longer wants the reward.

(b) The reward must be given to the dog only when it has made the required response.

(c) The reward must be given to the dog immediately after the dog makes the required response. If a food reward system is used, only enough should be given to the dog so it realizes it has been rewarded. Similarly, if the dog is rewarded with a ball or other play object, the dog should be allowed to keep it only briefly to realize it has been rewarded and so the dog does not become bored with the reward.

b. The response the dog will be trained to make when it performs detection tasks correctly is determined during initial training of the dog at the school. Some dogs will have been taught to make an aggressive response such as biting or scratching at a hiding place. Other dogs will have been taught a passive response such as barking or sitting. The school now teaches only the passive response.

c. An important element for training success is to train the dog to adapt to the various areas and objects around which it will be required to work. This lessens the effect that strange odors and surroundings may have on the dog and helps the dog to concentrate on the desired task. For this reason, the real working environment offers the best training ground. Areas that offer excellent training opportunities without exposing the MWD team in training to real situations include the following:

(1) Theaters which have been vacated at the end of a movie or training class.

(2) Commercial facilities just after close of business.

(3) MP unit areas anytime.

3-4. Where to train

a. *Working environment.* Much of the required proficiency training for an MWD team can and should be conducted in the working environment or in a similar one. Handlers and kennelmasters can use the handler's normal tour of MP duty to conduct training exercises that closely simulate the actual tasks (such as scouting, detection, and building search) that the MWD team may be required to do. Training scenarios can be designed to include concurrent training in several different tasks thus developing the team's ability to accomplish the operational mission. For example, a situation can be set up that allows the MWD team to discover an unsecured building while on walking patrol. The handler must request a backup patrol, secure the building area until the backup patrol arrives, enter and search the building, find one suspect who attempts to escape, pursue the suspect by sight, sound and/or scent, then attack and apprehend the suspect and escort him or her back to the building. This exercise provides realistic training in several tasks, to include the proper application of necessary force to apprehend a suspect. The handler must remember to give the necessary warnings to the suspect, as well as consciously applying the use of force principles (that is, minimum necessary force) before releasing the patrol dog to attack. This exercise could require that the backup MP patrol accomplish the apprehension rather than allowing the handler to release the dog. This aspect of the training exercise helps MWD teams and regular MP patrols develop their knowledge about how to work together.

b. *Training area.* Some training may be best conducted in a training area. Before going on duty, the handler should exercise the dog moderately, just as an athlete would warm up before an event. This pre-duty exercise is an ideal time for obedience exercises, on- and off-leash, and for exercise on the obedience course obstacles. Nearly all off-leash attack training should be conducted in the training area, especially if the kennelmaster or handler is trying to correct a control problem.

c. *Obedience course.* The obedience course exposes the patrol dog to various obstacles that simulate walls, open windows, tunnels, ramps, or steps. The exposure of the dog to these obstacles reduces the amount of time required to adapt dogs to the environment. The dog learns to negotiate each of the obstacles. Then, when confronted with a similar obstacle in the working environment it is not deterred from completing its mission. The obedience course also develops the handler's ability to control the dog's behavior both on- and off-leash. The obedience course is not a substitute for

exercise. A dog should never be required to negotiate the obedience course until it has been warmed up by proper exercise.

(1) The obstacles should be run in sequence as shown in figure 3–1. This sequence allows the dog to progress from least difficult to most difficult. The critical obstacles are adjustable so that the dog can be trained to accomplish the maximum height a little at a time.

(2) Veterinarians may determine that due to a particular medical or physical condition, a dog should not negotiate certain obstacles or the obedience course. Alternative exercises may then be prescribed.

(3) The obedience course obstacles are painted with an exterior paint, preferably white. The top surface of the steps, A–frame, and the dog walk are painted with a nonskid paint.

3–5. When to train

a. Since dogs, like people, have different levels of capability, characteristics, and behavior patterns, the amount of time that must be spent training to guarantee proficiency will vary. The general rule is that at least four hours of proficiency training each week is necessary to maintain minimum standards for each dog. The ability of the dog to maintain proficiency on separate tasks will also vary depending on the nature and complexity of the task. Kennel-masters and handlers must learn how long a dog can go before it begins to lose proficiency on various tasks. The most important factor is the length of time between task performances, not the amount of time spent on doing the task. Until the optimum training cycle is worked out, have the dog perform each task at least once each 5– or 6–day period. If the dog correctly performs without any particular problems, try increasing the interval. If the dog performs a task poorly, decrease the interval. Once the best training cycle (frequency of repetition of a task) has been determined, set up a training schedule that keeps the dog at peak proficiency. Keep the schedule in the dog's training record and stick to it!

b. When public or business facilities are used for training exercises, the training should begin as soon as possible after the facilities have been closed so that the lingering human scents provide a realistic working or training environment. Normally, a building would be evacuated for an explosives search. Patrol dogs and narcotics detector dogs should be able to work in buildings where there may be other persons present. Therefore, it may not always be necessary to totally vacate a building or area when training MWD teams.

3–6. How to conduct proficiency training

Training exercises that closely simulate actual performance requirements are the best form of training. Stereotyped exercises lead to stereotyped results with little training value. Repeatedly using the same exercise scenario makes it easier for the trainer; however, it also conditions the dog to anticipate the actions required and the dog will soon begin acting without waiting for commands from the handler. If this situation is allowed to continue, more serious control problems will result.

a. *Patrol dog team training.* To control the total amount of time spent on training and the frequency as much as possible, varied training exercises should be developed. Training should be tailored with emphasis on the dog's or handler's weaknesses. For example, if the dog team is weak in building searches, several training exercises should require the team to search a building (not the same building). The team should track a suspect to the building. As a variation, have the team detect a suspect near a building and chase the suspect into the building. Each training cycle, concentrate on the critical tasks as defined in sections II, III, and IV, below. Remember—never let training become routine or stereotyped.

b. *Detector dog training.* In addition to the proficiency training in patrol dog tasks, detector dogs require continued training in detection of narcotics (drugs) or explosives. Well–conducted and documented training are both critical to the maintenance of team certification and to the establishment of probable cause for a search based upon a detector dog's number of correct responses. Although there are several differences in the training requirements for drugs or explosives detection, proficiency training scenarios for both types of detector dogs must be varied to avoid conditioning the dogs to a repetitious training pattern. The following factors can and should be varied for each training exercise or proficiency evaluation:

(1) *The general training exercise area.* The places selected should be at random and should be different for each exercise. (This indicates if the dog responds to locations rather than the odor of the substance.)

(2) *The number of training aids planted.* Some exercises should involve no training aid plants. (This indicates if the dog has been trained using the same number of training aid plants each time and identifies false responding by the dog, cues made by the handler that cause false responding, and guessing by the handler.)

(3) *The specific locations of the training aids in the area being used for training.* The training aids should not be visible to the dog or handler and the hiding places should vary. (This indicates if the handler is cuing the dog or if the dog is cuing on places rather than the odor.)

(4) *The amount of explosives or drugs used in the training aid plant.* (This indicates if the dog responds to various odor concentrations.)

(5) *The type of explosives or drugs used.* To maintain proficiency includes maintaining detection proficiency for each of the substances the dog has been trained to detect.

(6) *The time of day or night of the training.* (This indicates whether the dog has been trained to work anytime or will only work at specific times.)

(7) *The type of training aid container.* For example, training aids may be packaged in cloth, plastic, metal, paper, cardboard, glass, or wood containers. (This indicates if the dog responds to the odor of the container rather than the substance.)

(8) *The type of distraction material planted with the training aid.* The training aids should always be uncontaminated and fresh. Distraction materials may be planted adjacent to the training aid. (This indicates if the dog responds to the odor of the distraction rather than the training aid.)

(9) *The length of time the training aid is left in place before the detector dog team search.* Varying the time will affect the extent of odor dispersion and the longer a training aid is in place the easier it is for the dog to detect.

(10) *The person used to handle and/or plant the training aid.* (This indicates whether the dog is responding to the odor of a specific person rather than the odor of the substance.)

(11) *The height above or below the floor level of the training aid plants.* (Matches most real world situations and forces the team to work scent cones and follow air current patterns to detect training aids.)

(12) *The size of the room or area in which the training aids are planted, such as an auditorium, an office, a closet, a desk drawer.* (Improves the detector dog team's use of search patterns and the ability of the team to work scent cones and follow air currents to detect narcotics and explosives.)

(13) *Storage location of the training aids.* Training aids stored together can cross-contaminate or become contaminated with the odors of the storage location. Training aids should be isolated in vapor proof containers when stored, if possible.

3-7. Decoys

a. One of the most important roles to be played in proficiency training and proficiency evaluation is that of the decoy. One or more decoys are essential. The decoy is the person used as the primary adversary role player for training and evaluating the MWD team. The decoy may be a suspect, a subject, an attacker, an agitator, a drunk, an escapee, an enemy or any of a number of other "persons" a dog team may expect to encounter while performing MP duties. A decoy may also be neutral or an ally, such as another MP, a supervisor, a lost juvenile, or an innocent person passing through an identification check.

b. To maintain realism, the decoy should not be familiar to the patrol dog. The less a decoy knows about dog training, the more realistic the decoy's behavior will be. The one thing that a decoy must be taught is how to handle the arm protector (or wrap) for self-protection when the dog attacks. The sleeve or wrap used should be a hidden sleeve rather than the full, heavy padded sleeve. The hidden sleeve can be concealed under a sweater or field jacket in order to achieve more realistic conditions for training the dog.

c. Both male and female personnel should be selected as decoys and both the military uniform and civilian clothing should be worn to improve realism. Military and civilian clothing obtained from the installation property disposal office is suitable for this activity.

Section II

Military Working Dog Team Proficiency Standards

3-8. Proficiency standards

a. The proficiency standards identified in section III, below, apply to all MWDs which are certified as patrol dogs at the dog school. The standards in section III describe how a task must be performed in the school environment for certification. As evaluation criteria, the correct performance of the required tasks serves to verify that the handler understands control of the patrol dog. In the operational working environment, the handler will usually need to adjust commands to deal with situations individually. For example, in a STAND-OFF, the handler may prefer to command DOWN or SIT rather than HEEL. This can avoid giving a suspect an opportunity to escape or to attack the dog or handler while the dog is returning to the HEEL position.

b. The proficiency standards identified in section IV, below, apply to all patrol dogs. These standards must be achieved within six months of team assignment to a unit or installation. They must be maintained for retention of certification as a patrol dog.

3-9. Degrees of criticality

To strengthen the usefulness of the proficiency evaluation of MWD teams and to rank corrective training efforts, the proficiency standards are assigned varying degrees of criticality, depending on their relative importance to the MP mission.

a. *Critical.* A task which is not performed consistently to at least the minimum standard seriously degrades the effectiveness of the MWD team. Dogs that fail to meet or exceed the minimum standards for these tasks for three consecutive days are considered unreliable. Unless there are known reasons for failures, the MWD team should begin immediate and extensive corrective training.

b. Semi-critical. Tasks that are done correctly provide a higher level of confidence in the dog team. Therefore, the team may be employed in a broader range of MP duties. Overall effectiveness is not degraded substantially by failure to perform a semi-critical task; however, corrective training must be applied to eliminate the deficiency.

c. Noncritical. Tracking is the only noncritical task for which patrol dogs are trained. Although tracking is a valuable skill for the patrol dog team, improper performance of the task does not degrade the overall effectiveness of the patrol dog team to perform its MP mission. Tracking also is identified as noncritical because not all patrol dogs have tracking potential. Normally, a patrol dog with tracking potential will be identified while still at the school at Lackland AFB, TX.

Section III

Patrol Dog School Certification Requirements

3-10. Obedience commands

On command from the handler, the patrol dog must execute the commands of SIT, DOWN, HEEL, and STAY. These commands must be executed when the dog is located at the handler's side and when the handler is positioned at least 10 feet away from the dog. Only one physical correction per four commands is allowed. The command STAY is rated critical due to its importance to controlled aggression and performance. The commands SIT, DOWN, and HEEL are rated semi-critical.

3-11. Obedience course (semi-critical)

The dog must be able to negotiate the obedience course at a moderate pace, on-leash, by command of its handler. This task is rated semi-critical. The obedience course and proper sequence of the obstacles (numbered 1 through 11) is shown in figure 3-1.

a. Task one (barrels one, two, three, and tunnel). On command, the dog will walk or crawl through the barrels of various lengths and the tunnel, immediately coming to the heel or sit position when each part of the task is completed.

b. Task two (steps). On command, the dog will climb up, then down the step obstacle, and immediately come to the heel and sit position when the task is completed.

c. Task three (jumps one, two, and three). On command, the dog will leap jump one at the 24-inch level, jump two at the 30-inch level, and jump three at the 36-inch level. The dog will come immediately to the heel or sit position after completing the task.

d. Task four (window). On command, the dog will jump up and through the window opening at a height of 36 inches, and immediately come to the heel or sit position on the other side of the obstacle.

e. Task five (A-frame). On command, the dog will scale the entire length of the A-frame in the full raised position, up and down, and immediately come to the proper heel or sit position.

f. Task six (dog walk). On command, the dog will climb and walk the entire length of the dog walk, and immediately come to the heel or sit position.

3-12. Controlled aggression

a. False run (critical). On the command STAY, the dog must remain in the heel or sit position, off-leash, and not attack when approached by a person. To evaluate, a person wearing an arm protector, starting from a position at least 40 feet away from the dog, approaches the dog to a distance of no closer than four feet from the dog, and then returns to the starting position. The arm protector must not touch the dog or be used to provoke the dog to respond incorrectly. This task is rated critical.

b. Attack (critical). The patrol dog must stay in the heel or sit position, off-leash, and attack only on the command GET HIM. The dog must leave the handler's side and attack a person wearing an arm protector. The person must be positioned at least 40 feet away from the dog team. The dog must complete the attack, bite, and hold the arm protector for at least 15 seconds, and release on the command OUT. This task is rated critical.

c. Search and attack (critical). The dog must, on the command STAY, remain in the down or sit position while the handler searches a person. If there is any attempt to escape or if the person initiates any hostile act against the handler or the dog, the dog must attack without command and hold the person for at least 15 seconds. After the search, the handler moves to a position about two feet to the right and 10 feet to the rear of the person, so the person is positioned between the dog and the handler. Then, facing the dog, the handler commands the dog to HEEL. The dog must move to the HEEL position next to this handler without attacking the person. The person must not touch the dog or attempt to provoke the dog to attack. This task is rated critical.

d. Stand-off (semi-critical). The correct response for this task is for the dog to cease pursuit of an agitator on the command OUT, then on the command of HEEL return to the handler. During school training, the dog may bite or nip at the agitator, but the dog must respond to verbal correction and return to the HEEL position on command. This task is rated semi-critical.

e. Escort (semi-critical). With the dog in the heel position, the handler and dog escort the person for a distance of at least 10 meters. The dog must stay in the heel position, off-leash, and not attack. This task is rated semi-critical.

3-13. Building search (critical)

The patrol dog must find one person in a building and show the handler the location of the person. The dog also must show proficiency in attacking a person who tries to escape or who tries to harm the handler or the dog. For school certification, the dog must be on-leash. This task is rated critical.

3-14. Small arms fire (critical)

The patrol dog must not be deterred from attacking during gunfire. This task is rated critical.

3-15. Scouting or patrolling (critical)

The patrol dog must be able to detect a person by scent, sound, and sight. This task is rated critical. The following tasks must be accomplished to demonstrate proficiency in scouting or patrolling:

- a.* Detect and respond to the odor or scent of a person who is hidden 50 meters upwind and follow the odor or scent to the person's location.
- b.* Detect and respond to a sound made by a person 100 feet downwind and follow this sound to the source.
- c.* Visually detect and respond to a person in view 100 feet downwind and pursue the person on command.
- d.* The patrol dog must demonstrate proficiency in pursuit and attack during this detection work.

3-16. Vehicle patrol (semi-critical)

The patrol dog must ride quietly and calmly inside a vehicle with the handler. The patrol dog must not be aggressive towards passengers or the driver. The driver may or may not be the handler.

3-17. Tracking (noncritical)

Patrol dogs which demonstrate a potential for tracking are identified at the dog school. This information is recorded on DD Form 1834 (Military Working Dog Service Record) and is given to the gaining unit or installation.

Section IV

Patrol Dog Team Postgraduation Certification Requirements

3-18. Certification standards

After a patrol dog team completes formal training and is assigned to an organization, the patrol dog's proficiency is increased through unit team training. This section prescribes the minimum proficiency standards which each patrol dog team must meet within seven months after being assigned to a unit. These standards must be maintained for certification from then on. This unit team training is accomplished at the kennel training area and in all areas of the installation where MP missions would reasonably dictate a need for familiarizing the team. The training environment should approximate the MP working environment as closely as possible. Training should occur at varying times throughout the day and night and on varying days of the week, including weekends. The patrol team must perform these tasks whether the personnel used as suspects are male or female, and whether they are dressed in military or civilian clothing. The emphasis in training must be on developing the skills of both the handler and the dog so that they complement each other and the team becomes a working unit. As proficiency evaluation criteria, the correct performance of these required task serves to verify that the handler understands how to control his or her patrol dog and is able to do so. In the working environment, the handler usually will need to adjust commands to deal with the individual situation. The team should be required to develop skills using both verbal command and visual commands (hand and arm signals) so that the patrol dog is responsive to either type of command.

3-19. Obedience commands

a. On command from the handler, the patrol dog must execute the commands of SIT, DOWN, HEEL, and STAY. The dog must execute correctly the commands when the dog is located at the handler's side and when the handler is positioned at a distance of 50 feet with no more than one correction per five commands. On the command of STAY, either in the SIT or DOWN position, the patrol dog must remain in that position for at least three minutes. The commands STAY and HEEL are rated critical. The commands SIT and DOWN are rated semi-critical.

b. While off-leash, the patrol dog will maintain a proper heel position while the handler starts, stops, changes speed, changes direction, and executes passing movements. Movements the dog team must be able to perform include forward march, rear march, column left, column right, and halt. These and other marching movements are rated semi-critical.

c. Recall will consist of calling the dog from a distance of 50 feet and stopping the dog at a distance of 25 feet with a SIT or DOWN command. The dog will then be called to HEEL position with a voice command. Recall is rated semi-critical.

3–20. Obedience course (semi-critical)

The patrol dog must negotiate the obedience course at moderate rate of speed, on-leash or off-leash, by command of its handler. When off-leash, the patrol dog will maintain the heel position while the patrol dog handler walks the dog through the course. Random stops will be made between obstacles, and some obstacles will be passed to ensure that the dog is responding to the handler's direction and not simply "running the course." This task is rated semi-critical.

3–21. Controlled aggression

When evaluating the patrol dog team on controlled aggression tasks, situations and locations should closely approximate real working situations. Evaluation exercises must not be limited to the kennel training area, but done in areas where MWD teams may be realistically employed.

a. False run (critical). When the MWD team confronts a group of at least two persons and the dog is commanded to STAY, the patrol dog must remain in the heel or sit position, off-leash, and not attack when the MWD team is approached by one of the persons. One person wearing a concealed arm protector, the decoy, approaches no closer than four feet from the dog and then returns to the starting position. The decoy should not touch or provoke the dog or make any hostile gestures toward the handler. This task is rated critical. An appropriate evaluation exercise would be to have the decoy approach the MWD team, present an identification card to the handler by placing it on the ground; the handler retrieves the card, examines it, and then replaces it on the ground; the decoy reclaims the card and returns to the group or leaves the area. The handler should never break the line of sight between the patrol dog and the decoy. Alternatively, the decoy may present identification directly to the handler if the dog has developed sufficient tolerance for persons approaching that closely.

b. Attack (critical). The patrol dog must stay in the heel or sit position, off-leash, and attack only on the command GET HIM. The decoy may be running toward or running away from the dog team. When the handler commands the dog to attack, the decoy halts and prepares to meet the attacking dog. The dog must complete the attack, bite and hold the decoy (using the arm protector), hold the bite for at least 15 seconds, and release on the command OUT. The patrol dog must return to its handler when commanded to HEEL. This task is rated critical. To develop a full range of appropriate attack responses, the patrol dog also must be trained to attack, bite, and hold a decoy who does not stop to meet the attacking dog. Similarly, after the command OUT, the dog should be trained to respond to commands other than HEEL, such as SIT, DOWN, and STAY so that the dog is prepared to reattack on command.

c. Search and attack (critical). The patrol dog must, on the command STAY, remain in the heel, down, or sit position while the handler searches a decoy. The search will consist of patting down both arms, both legs, and the torso of the decoy. During the search, the dog must attack the decoy without command if the decoy tries to escape or to attack the handler. The patrol dog must bite and hold the decoy for at least 15 seconds, and release on the command OUT. After the search, the handler moves to a position about two feet to the right and 10 feet to the rear of the decoy, so that the decoy is positioned between the dog and the handler. The handler faces the dog and commands the dog to HEEL. The dog must respond to the command without attacking the decoy. This task is rated critical. The patrol dog will be trained to not interpret movement by the decoy as a reason to attack. Some movement must be expected from a person being searched.

d. Stand off (critical). The correct response for this task is for the dog to cease pursuit of a decoy on the command OUT, then on command of HEEL, the dog will return to the handler. This task is accomplished off-leash, and the decoy may be moving or standing. Only one command of GET HIM will be given. Only one correction may be used to enforce the OUT command. If the decoy is moving, when pursuit begins, the decoy will not stop moving until the dog obeys the OUT command. The decoy will do nothing to cause the patrol dog to attack when the original command of GET HIM is given. This task is rated critical.

e. Escort (semi-critical). With the patrol dog in the Heel position, the MWD team must escort the decoy for at least 20 meters to a vehicle. The dog must stay in the heel position, off-leash, and will not attack while the decoy is placed into the vehicle. This task is rated semi-critical.

3–22. Building search (critical)

The patrol dog must find three decoys in different locations inside any structure, and show the handler where the decoys are located. For certification, this task must be done both on- and off-leash. When working off-leash, the handler will remain at the entrance until the dog indicates it has found one of the decoys. If the dog returns to the handler and then returns to the location of the decoy, this is sufficient. A patrol dog must be able to search away from the handler on its own. This task is rated critical.

3–23. Gunfire (critical)

The patrol dog must not be adversely affected by gunfire, either when the handler or another person is firing. The dog may respond on gunfire. However, gunfire will not be a command for the dog to attack. The patrol dog will hold its position while its handler or another person is firing a weapon. The dog will attack, only on command, a decoy who is firing a weapon. This task is rated critical.

3-24. Scouting or patrolling (critical)

The patrol dog must be able to find people by scent, sound, and sight. This task is rated critical. Proficiency in scouting or patrolling requires demonstrating the ability to detect persons according to the following criteria:

- a.* Detect and respond to the scent of one or two decoys who are hiding together or in separate locations, upwind at least 100 meters but not more than 200 meters, and follow the scent(s) to the decoy(s) location(s).
- b.* Detect and respond to the sound made by one or two decoys who are hiding together or in separate locations at least 100 feet downwind and follow the sound(s) to the source(s).
- c.* Visually detect and locate one or two decoys who are downwind together or in separate locations show the handler their locations. Night detection will be evaluated at a distance of at least 25 meters but not more than 50 meters. Daylight detection will be evaluated at a distance of at least 150 meters but not more than 250 meters.
- d.* The patrol dog will pursue and attack only on command.
- e.* The handler will respond properly each time the patrol dog responds. He or she will make proper use of the wind for an area search and will be able to state whether the patrol dog's response is for scent, sight, or sound. If the dog loses the scent, the handler will demonstrate the proper technique to help the dog regain the scent.

3-25. Vehicle patrol (semi-critical)

The patrol dog must ride quietly and calmly in a vehicle that the handler is driving and not show any aggressiveness toward passengers. The handler will not allow the dog to ride with its head outside of the window. The handler must demonstrate the procedures for mounting and dismounting from any assigned vehicle and will demonstrate his or her ability to control the dog while in the vehicle. This task is rated semi-critical.

3-26. Tracking (noncritical)

a. All patrol dogs identified as having tracking potential will receive tracking training to develop this potential. As a general rule, at least one out of every 10 patrol dogs can and should be trained for tracking. Tracking training takes a lot of patience and determination on the part of the handler. The patrol dog must not only have some natural ability for tracking, but also must have some natural willingness to track. Patrol dogs selected for tracking training should be trained and employed for tracking on a tracking harness. The harness serves as a useful cue to the patrol dog that it should focus its senses on tracking. Tracking harnesses may be procured by the unit and should be issued to the tracking dog handler for use with the dog.

b. The minimum level of proficiency a patrol dog trained for tracking must attain is to be able to follow the scent of a human on a scent at least one hour old for one mile over varied terrain on a course with several turns. Given suitable tracking conditions, a skilled tracer dog team can follow the natural wanderings of individuals or groups of persons for a least 5000 meters over rugged and varied terrain, on a scent track that is at least 12 hours old. While tracking, the dog is also capable of alerting its handler to the presence of tripwires and ambushes. Additional information on tracking can be found in FM 19-35, chapters 2 and 5. The tracking skill is rated noncritical.

Section V

Proficiency Training and Evaluation of Detector Dog Teams

3-27. Certification standards

a. The operational effectiveness of narcotics detector dogs depends on continual reinforcement of the detection ability through proficiency training. A minimum of four hours narcotics detection proficiency training is mandatory each week. This proficiency training is in addition to the patrol dog proficiency training for all patrol-trained dogs. The minimum standard of proficiency to maintain certification as a narcotics detector dog team is a 90 percent or better detection rate. Failure to maintain an average that meets or exceeds this minimum standard for three or more consecutive months results in automatic decertification of the team. The team may be recertified only after retraining and consistent demonstration of proficiency to an authority. Narcotics or contraband training aids, which are procured according to the procedures described in chapter 4, are essential for proficiency training.

b. The greater complexity and danger of explosives detection requires that the proficiency standards for EDD teams be significantly higher than for any other type of MWD team. Therefore, certification depends on the demonstrated knowledge and handling skill of the handler and the explosives detection rate of the EDD.

(1) Handler proficiency is evaluated by having the handler demonstrate detailed knowledge of:

- (a)* The characteristics of each of the explosives the team is trained to detect.
- (b)* How these explosives may be used in explosive devices.
- (c)* The requirements for safe handling, transportation, and storage of these explosives.
- (d)* The requirements for conducting safe training exercises.

(2) The handler must be a capable instructor so that other MPs can be trained to support an EDD team. The handler must have detailed knowledge of bomb threat response procedures and must be involved in bomb threat planning. This will ensure the operational needs of the explosives detection team are met, giving the team the greatest opportunity to detect the presence of explosive substances.

(3) The EDD must receive a minimum of four hours explosives detection proficiency training each week. This proficiency training is in addition to the required patrol dog proficiency training for all patrol-trained dogs. The minimum standard of proficiency to maintain certification as an EDD team is a 95 percent or better detection rate. Failure to maintain an average that meets or exceeds this minimum standard for three or more consecutive months results in automatic decertification of the EDD team. The team may be recertified only after retraining and consistent demonstration of proficiency to a certification authority.

(4) Explosives training aids, which are procured according to the procedures described in chapter 5, are essential for proficiency training. Proficiency cannot be maintained without explosives training aids. Any EDD, whose detection rate falls below the 95 percent detection rate standard in any single month should be entered immediately into remedial proficiency training to ensure that problems are corrected before they become more serious.

3-28. The narcotics detector

Narcotics detector dogs are trained to detect concealed marihuana, hashish, heroin, and cocaine. Some narcotics detector dogs also may be trained to detect additional narcotics or drug contraband substances, such as amphetamines or barbiturates. Narcotics detector dogs are not trained to detect drug substances, such as PCP, that present a significant health and safety threat to the dog. Narcotics detector dogs are not trained to detect explosives. The credibility of the narcotics detector dog team is critical to the establishment of probable cause and the authorization to search. Therefore, the narcotics detector dog should never be trained to detect anything that would detract from the team's credibility. The narcotics detector dog's detection proficiency should be maintained on all of the narcotics and drug contraband substances the dog has been trained to detect and all training should be thoroughly documented in training records.

3-29. The explosives detector

The EDD is trained to detect several types of commercial and plastic explosive, detonating cord, potassium chlorate, and sodium chlorate. No training should ever be conducted which could damage the public's trust and confidence in the EDD team. The EDD team's detection proficiency should be maintained on all of the explosives the dog had been trained to detect. All training should be thoroughly documented in training records.

3-30. Proficiency training of detector dogs

All of the principles applied to the proficiency training of patrol dogs apply equally well to the proficiency training of detector dogs. That is, the training environment should be as close to the working environment as possible. Training scenarios should involve realistic situations, including decoys, supporting MPs, and supervisors. If there are opportunities to conduct training in the working environment, these should be used to train both the detector dog team and the supporting MPs. Training is automatically conducted any time training aid plants are used during an actual search to help maintain the dog's interest. Some of the principles which apply to the proficiency training of detector dogs are as follows:

a. All detector dogs must receive a minimum of four hours detection proficiency training each week. Detection training is in addition to the mandatory four hours minimum patrol dog proficiency training for all patrol-trained dogs. Even the nonpatrol-trained detector dogs must receive some obedience training, although the full four hours may not be necessary. The general rule is to train as much and as often as necessary to maintain the desired level of proficiency. There is, of course, some trade-off between training time and utilization time. Every handler also has unit responsibilities. Therefore utilization time may fluctuate depending on the extent of these responsibilities. Although the utilization goal is 30 hours per week, increased proficiency training requirements may reduce the ability of the team to be used the full 30 hours per week. Unit commanders must balance the handler's operational and training responsibilities with unit responsibilities to ensure that the MWD team is ready to perform the MP mission.

b. The detector dog should not be expected to detect an odor unless the dog has access to the odor. The following will have a direct bearing on whether the odor will or will not be accessible to the detector dog:

- (1) The quality of the substance.
- (2) The length of time it has been in place.
- (3) The type of container enclosing the substance.
- (4) Heat.
- (5) Humidity.
- (6) Air currents.

c. The odor of a substance may be present in enough concentration to cause the dog to respond even after the substance has been removed. Therefore, when a detector dog responds and no drug or explosive is found, do not assume the dog has made an error. Some substances that are not illegal or dangerous have the same odor as the substances the detector dogs are trained to detect. When such substances are identified, their identity is included in the training program. In this way, handlers can differentiate between responses on these substances as opposed to a genuinely false response.

d. Training aids are planted during actual searches to keep the dog from exceeding the maximum search time and

losing interest. Training aid plants also provide a periodic verification during an actual search that the dog is working consistently. This training also helps the dog's continuing adaptation to all working environments.

e. The person hiding training aids during training exercises should be varied to prevent the dog from responding on the person's scent. The handler's scent is very familiar to the dog. If the handler consistently hides the training aids, the detector dog quickly learns to respond on the handler's scent rather than the substance and numerous nonproductive responses may result. An increasing number of nonproductive responses is a good indication that this situation exists. By that time, extensive retraining may be necessary to correct the problem.

3-31. Proficiency evaluation of detector dog teams

a. Records. The proficiency of a detector dog team can be evaluated by reviewing the training and utilization records. The records will reveal the frequency of proficiency training, the amount of time which has been spent in training, the types of substances on which training has been conducted, and the performance record of the detector dog team in training and on duty. The detector dog's proficiency rating also is recorded on the training and utilization record. A proficiency evaluation based on records always should include at least three months records (at least one year worth of records are required), and should clearly substantiate the detector dog team's ability. The detector dog's proficiency rating should meet or exceed the detection rate standard of 90 percent for narcotics detector dogs and 95 percent for explosives detector dogs.

b. Demonstration. The detector dog team may be required to demonstrate its proficiency if an authority is not satisfied that the training and utilization records have clearly substantiated the team's ability. Some of the performance indicators which help to verify the detector dog team's ability are as follows:

- (1) The dog team should approach the area or object to be searched from downwind whenever possible.
- (2) The handler should give the command SEEK to start the search.
- (3) On command, the dog should actively search, sniffing areas and objects as shown by the handler.
- (4) The search should be systematic and overlook nothing capable of hiding the substance being sought. The search should start from the outside to the inside, and from left to right. A scan of the area to be searched before the detailed systematic search is acceptable. However, the dog must stay on-leash at all times during the presearch scan.
- (5) When the dog smells an odor it was trained on, it should try to go to the source of the odor and give a response (alert) recognizable to the handler. Some dogs are trained to give a passive response (sit, bark, and so forth) and other dogs will give an aggressive response (excitement, scratching, pawing, biting, and so forth).
- (6) The handler should recognize the dog's response, praise or reward the dog, and continue to search until the demonstration is complete.
- (7) The number and type of training aids selected should be appropriate to the purpose of the demonstration.

3-32. Validation tests

a. Validation tests will be given by the kennelmaster, at least quarterly, to verify the detection accuracy rates recorded on DA Form 3992-R. Validation tests will be given to any detector dog whose demonstrated proficiency appears to significantly differ from the rating recorded on the DA Form 3992-R. The validation test should verify proficiency or identify the specific detection weaknesses which need corrective training.

b. Validation tests should include at least 20 trials for a narcotics detector dog and at least 45 trials for an EDD. These trials should be divided so at least five trials are made with each substance the dog is trained to detect.

c. Training aids should be distributed in at least four different areas over a 2-day period. A person fulfilling the requirements of a decoy will be used to make the training aid plants. Every type of substance which the dog has been trained to detect will be used during validation testing.

Section VI

Administrative Records

3-33. DD Form 1834 (Military Working Dog Service Record)

- a.* DD Form 1834 contains the official and physical description of the MWD when the dog is procured.
- b.* The form is completed and issued by the 341st Military Working Dog Training Squadron with initial assignment of the dog after training.
- c.* The form records all certification training at the MWD Squadron received by the dog throughout the dog's service career.
- d.* Each time a new handler is assigned to the dog, the handler information is recorded on the back of the form.
- e.* The section titled "Final Disposition" is completed by the organization to which the dog is assigned at the time the dog dies or undergoes euthanasia.

3-34. DA Form 2807-R (Military Working Dog Training and Utilization Record)

a. DA Form 2807-R is a daily record of training and employment activities for all MWDs. (See fig 3-2 for a completed sample.)

- b.* Entries are the responsibility of the handler.
- c.* When completed, the record provides a daily report of training, utilization, and feeding for one month which can aid in identifying training deficiencies and can improve the utilization of the MWD team.
- d.* When the form is used to schedule training or duty, it helps to ensure that:
 - (1) Scheduling conflicts are avoided.
 - (2) Training and utilization rates are maintained.
 - (3) All tasks are repeated frequently enough to maintain team proficiency.
 - (4) Corrective training is sufficiently intensive to be productive.
- e.* One form is required for every MWD each month and forms are retained in the dog's record for at least one year from the date of the last entry on each form.
- f.* When completed, the form gives the handler, the kennelmaster, the commander, the veterinarian, and other supervisors essential training, utilization, and health management data.
- g.* A copy of DA Form 2807-R is located at the back of this handbook, and can be locally reproduced on 8 1/2 by 11-inch paper.

3-35. DA Form 3992-R (Narcotics or Explosives Detector Dog Training and Utilization Record)

a. DA Form 3992-R will be used as a daily record of training, use, and performance of all narcotics and EDD teams.

(1) This form is used in addition to DA Form 2807-R, and is intended to be an accurate record of the training, utilization, and proficiency status of the detection capability for each detector dog. AR 190-12 prescribes the use of the form. (See fig 3-3 for a completed sample.)

(2) Its purpose is to record and establish the detector dog's detection reliability by using training aids during both training and actual searches.

(3) It is specifically a record of the detector-related training and utilization of the detector dog team.

(4) At least one form is required for every detector dog every month.

(5) The handler is responsible for the information entered on the form.

(6) When completed, the form gives the handler, the kennelmaster, the commander, the veterinarian, and other supervisors essential training, utilization, and health management data.

(7) Completed DA Forms 3992-R will be retained in the administrative record for at least one year from the date of the last entry on the form.

(8) A copy of DA Form 3992-R is located at the back of this handbook and can be locally reproduced on 8 1/2 by 11-inch paper.

b. The training section of the form is used for recording all training of the detector dog team in the detection skill. All detection training is conducted using all appropriate training aids.

(1) In order to maintain the detector dog's proficiency, the dog must receive training on each of the substances it has been trained to detect. The frequency with which the dog is trained on each substance is a very important part of maintaining the dog's proficiency. Accordingly, the handler must keep a training record that shows the frequency with which the handler trains with the dog on each of the appropriate training aids. The training record must also show the proficiency of the dog at detecting each of the required substances.

(2) A suggested method of keeping this training record is to use a separate DA Form 3992-R for each substance the dog is trained to detect. By consecutively numbering all the forms for a particular month, the forms also may be used to record utilization and detector dog search data in chronological order. For example, a narcotics detector dog is trained to detect marihuana, hashish, heroin, and cocaine. Using one DA Form 3992-R for each substance, the form for marihuana is number one, hashish is number two, heroin is number three, and cocaine is number four. Training and proficiency data are entered on the appropriate form. Utilization data is entered on form number one. Forms two, three, and four would only be used if the commander, kennelmaster, or handler wanted to account separately for more than one mission on each calendar day. That is, the second mission of the day is entered on form number two, the third mission on form number three, and so on. Detector dog search data is entered chronologically on form number one. Forms two, three, and four are used, in turn, when all the lines on the preceding form are filled in.

(3) The goal here is not to produce a set of complicated and confusing rules about how to use these forms. Instead, the goal is to suggest some of the ways that the forms can be used to develop meaningful training and utilization data. This data should improve the proficiency of the detection team and ensure that team assets are being used effectively and efficiently to support the mission.

c. The utilization section is used to record all operational detection missions. If desired, when training aid plants are used during actual searches, the handler can keep track of the number of training aids planted and the number found by recording those numbers in the training section. However, utilization search time should not be counted as training time even if training aids are used. Also, training aid finds should not be included in the total number of finds during an actual search.

d. The detector dog search data section is used by the handler to record all relevant information about the

productivity and success of each detection mission. Remember to use the remarks section (or a separate sheet of paper) to record any information which may be useful in preparing the team for future searches, or which may be applicable or useful to other detector dog teams. The greater the amount of information shared among detector dog handlers, the more successful the detector dog program will become.

e. When making entries in the detector dog proficiency section, remember that the only way to determine proficiency accurately is to know the exact number of substances (training aid plants) which are supposed to be found. This is the only way to be able to differentiate between correct responses and false/missed responses. The control of the majority of variables in a training environment ensure that the dog is responding to the real substance in the training aid rather than a masking agent, a distraction, or some other external cue.

f. The integrity of the handler and kennelmaster to record both the successes and failures of the detector dog team is critical to the credibility of the detector dog program. The commander places a significant trust in the narcotics detector dog handler because the dog's response serves as the basis for an authorization to search and the possible criminal prosecution of a person. For the EDD handler, the quick identification of training or operational deficiencies may mean the difference between a successful detection of an explosive device or the tragic loss of life or property. No handler should ever betray the commander's trust.

g. Remember that total training and utilization hours for a detector dog is computed by adding together the training time and utilization time reported on both DA Form 2807-R and DA Form 3992-R.

Section VII

Training of Nonhandler Military Police Personnel

3-36. Military police training

Any personnel that are routinely expected to work with an MWD team as a partner or back up for the team should be educated about the functions dog teams perform, how to work safely around an MWD team, and how to support the MWD team without interfering with the dog. The kennelmaster and the individual handlers probably are the best qualified personnel to provide this instruction to other MP personnel. All MP personnel should be able to answer the following questions:

- a.* What effect does wind have on how a dog works?
- b.* Where should you be when the dog is being used to clear an area or building?
- c.* Where should you be when the dog is tracking?
- d.* Who will do the search of a person if you are to properly assist a handler when a search of a suspect is necessary? (The common rule is that the handler does the search with the dog as primary backup and other MP personnel as secondary backup.)
- e.* What do you do if the dog handler is hurt or unconscious and you have to aid them?
- f.* How do you support a narcotics detector dog team?
- g.* How do you support an explosives detector dog team?

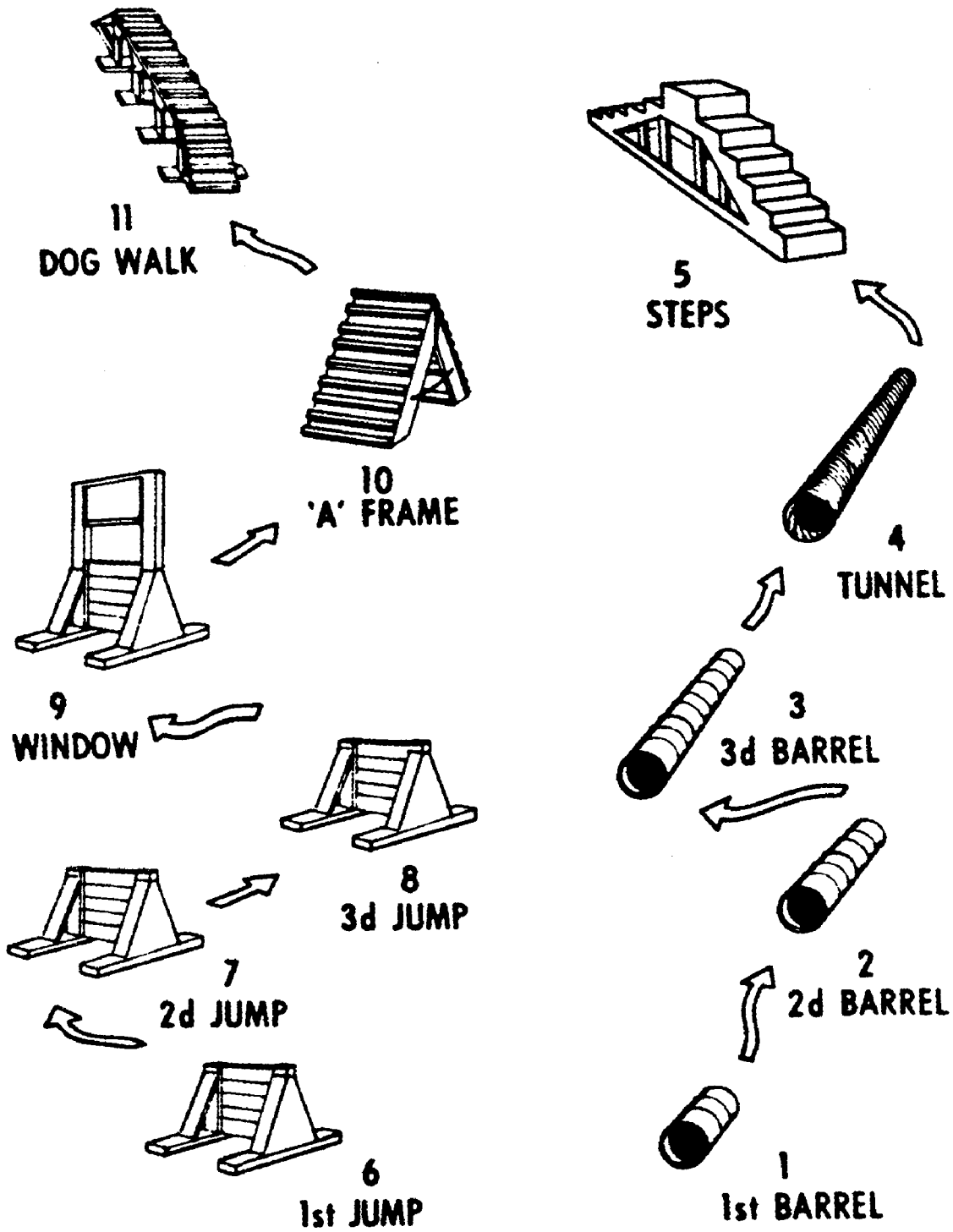

**EACH OBSTACLE IS 15 TO 20 FEET FROM PREVIOUS OBSTACLE
AND COURSE RUNS IN SEQUENCE**

Figure 3-1. Obedience course

MILITARY WORKING DOG TRAINING AND UTILIZATION RECORD										MONTH AND YEAR																								
For use of this form, see AR 190-12; proponent agency is ODCSOPS										JUN 84																								
NAME/TYPe OF DOG			TATTOO NUMBER			AGE			NAME OF HANDLER			GRADE		ORGANIZATION AND LOCATION																				
THOR / PATROL			D123			S			MAY T.			SGT		123B MP COMPANY FT IRON GA 12345																				
DAILY RATINGS: S - SATISFACTORY, U - UNSATISFACTORY (Explain deficiency and corrective action on reverse)																																		
Use reverse side of this form for any remarks or notes.																																		
TRAINING	DAY OF MONTH																														TOTAL HOURS			
	1	2	3	4	5	6	7	8	9	10	11	12	13	14	15	16	17	18	19	20	21	22	23	24	25	26	27	28	29	30		31		
1. ON LEASH OBEDIENCE	S	S					S	S				S	S	S	S	S	S	S	S	S	S	S	S	S	S	S	S	S	S	S	S	S	4	
2. OFF LEASH OBEDIENCE	S	S					S	S				S	S	S	S	S	S	S	S	S	S	S	S	S	S	S	S	S	S	S	S	7		
3. OBEDIENCE COURSE	S	S					S	S				S	S	S	S	S	S	S	S	S	S	S	S	S	S	S	S	S	S	S	S	4		
4. CONTROLLED AGGRESSION (S or U)																																		
a. FALSE RUN																																		
b. ATTACK																																		
c. SEARCH AND ATTACK																																		
d. STAND-OFF																																		
e. ESCORT																																		
5. BUILDING SEARCH																																		
6. GUNFIRE - HANDLER																																		
7. GUNFIRE - DECOY/AGITATOR																																		
8. SCOUTING/PATROLLING (TIME)																																		
a. SCENT DETECTION (DISTANCE)																																		
b. SIGHT DETECTION (DISTANCE)																																		
c. SOUND DETECTION (DISTANCE)																																		
9. VEHICLE PATROL																																		
10. TRACKING																																		
11. DAILY TRAINING RATING (S or U)																																		
UTILIZATION															HOURS PER DAY										TOTAL HOURS									
COMBAT SUPPORT OPERATIONS																																		
PATROL - LAW ENFORCEMENT																																		
PATROL - SECURITY																																		
DAILY UTILIZATION RATING (S or U)																																		
DAILY FEEDING															QUANTITY OF FOOD (BY WEIGHT)										WT OF DOG									
1. MSD - MEDICATED (OUNCES)																																		
2.																																		

Figure 3-2. Sample completed DA Form 2807-R

NARCOTICS OR EXPLOSIVES DETECTOR DOG TRAINING AND UTILIZATION RECORD															MONTH AND YEAR																																	
For use of this form, see AR 190-12; proponent agency is ODCSOPS															JUL 84																																	
NAME/TYPE OF DOG	TATTOO NUMBER	AGE	NAME OF HANDLER	GRADE	ORGANIZATION AND LOCATION																																											
ZEUS/PATROL - Marc Det	N 321	6	DOUGHOBY, P.	SGT	321st MP COMPANY FT BOARD, KY 54321																																											
DAY OF MONTH															TOTAL HOURS																																	
TRAINING															1	2	3	4	5	6	7	8	9	10	11	12	13	14	15	16	17	18	19	20	21	22	23	24	25	26	27	28	29	30	31			
BUILDINGS	PLANTS/ FINDS	/														19	6	6	6	6	6	6	6	6	6	6	6	6	6	6	6	6	6	6	6	6	6	6	6	6	6	6	6	6	6	6	6	
	SEARCH TIME	/														2	1	1	1	1	1	1	1	1	1	1	1	1	1	1	1	1	1	1	1	1	1	1	1	1	1	1	1	1	1	1	1	1
CONTAINERS	PLANTS/ FINDS	/														8	6	6	6	6	6	6	6	6	6	6	6	6	6	6	6	6	6	6	6	6	6	6	6	6	6	6	6	6	6	6	6	6
	SEARCH TIME	/														1	1	1	1	1	1	1	1	1	1	1	1	1	1	1	1	1	1	1	1	1	1	1	1	1	1	1	1	1	1	1	1	1
VEHICLES	PLANTS/ FINDS	/														8	6	6	6	6	6	6	6	6	6	6	6	6	6	6	6	6	6	6	6	6	6	6	6	6	6	6	6	6	6	6	6	6
	SEARCH TIME	/														1	1	1	1	1	1	1	1	1	1	1	1	1	1	1	1	1	1	1	1	1	1	1	1	1	1	1	1	1	1	1	1	1
DAY OF MONTH															1	2	3	4	5	6	7	8	9	10	11	12	13	14	15	16	17	18	19	20	21	22	23	24	25	26	27	28	29	30	31			
UTILIZATION															1	2	3	4	5	6	7	8	9	10	11	12	13	14	15	16	17	18	19	20	21	22	23	24	25	26	27	28	29	30	31			
BUILDINGS	FINDS	/														6	1	1	1	1	1	1	1	1	1	1	1	1	1	1	1	1	1	1	1	1	1	1	1	1	1	1	1	1	1	1	1	
	SEARCH TIME	/														12	15	4	3	4	3	4	4	3	4	4	4	10	10	13	10	10	12	23	4	4	14	27	4	4	4	4	4	4	17	4		
CONTAINERS	FINDS	/														1	4	4	4	4	4	4	4	4	4	4	4	4	4	4	4	4	4	4	4	4	4	4	4	4	4	4	4	4	4	4	4	
	SEARCH TIME	/														1	4	4	4	4	4	4	4	4	4	4	4	4	4	4	4	4	4	4	4	4	4	4	4	4	4	4	4	4	4	4	4	
VEHICLES	FINDS	/														0	2	4	4	4	4	4	4	4	4	4	4	4	4	4	4	4	4	4	4	4	4	4	4	4	4	4	4	4	4	4	4	
	SEARCH TIME	/														0	2	4	4	4	4	4	4	4	4	4	4	4	4	4	4	4	4	4	4	4	4	4	4	4	4	4	4	4	4	4	4	

EDITION OF 1 DEC 72 IS OBSOLETE

DA FORM 3992-R, Oct 84

Figure 3-3. Sample completed DA Form 3992-R

DETECTOR DOG SEARCH DATA									
NO.	TIME	DATE	LOCATION	MPR NUMBER	SUBSTANCE	QUANTITY	REMARKS		
1	0630	15JUL	B / 1-21 INF	634-84	MARIJUANA	50 grams	Field test verified		
2	0730	23JUL	Bldg 501	647-84	COCAINE	6 grams			
3	1030	33JUL	C / 2-37 ARMOR	649-84	COCAINE	3 grams			
4	0900	5JUL	C / 2-4 CAV	659-84	MARIJUANA	20 grams	Field test verified		
5	0530	6JUL	R / 1-19 INF	663-84	MARIJUANA	43 grams	Field test verified		
6	1945	9JUL	D / 323 ENG	682-84	MARIJUANA	100 grams	Field test verified		
7	2015	10JUL	Bldg 523	690-84	MARIJUANA	63 grams	Field test verified		
8	2030	11JUL	Bldg 677	699-84	MARIJUANA	71 grams	Field test verified		
9	2330	12JUL	MAIN GATE	712-84	MARIJUANA	19 grams			
10	2130	13JUL	SOUTH GATE	720-84	MARIJUANA	28 grams			
11	1945	17JUL	ATCS 1473-SOUTH POST	726-84	HEROIN	5 grams			
12	2240	18JUL	NORTH GATE	733-84	HASHISH	10 grams	Field test verified		
13	2130	19JUL	ATCS 1475-SOUTH POST	740-84	MARIJUANA	104 grams			
14	2010	20JUL	C / 1-37 ARMOR	742-84	MARIJUANA	37 grams	Residue, Seeds		
15	0700	23JUL	A / 1-19 INF	750-84	MARIJUANA	10 grams	Residue, Seeds		
16	0745	24JUL	C / 323 ENG	758-84	MARIJUANA	17 grams	Residue, Seeds		
17	0630	25JUL	155TH AVN CO	798-84	MARIJUANA	5 grams	Field Test Verified		
18	0900	26JUL	D / 1-55TH ADA	807-84	MARIJUANA	18 grams			
19	0530	31JUL	MHC / 56TH TRANS	826-84	MARIJUANA	154 grams			
20									
21									
22									
23									
24									
25									
26									
27									
28									
29									
30									
31									
32									
33									

DETECTOR DOG PROFICIENCY																																	
(Alerts on training aids during training and actual searches)																																	
		DETECTOR DOG PROFICIENCY																															
		100% = 917																															
		205																															
		PROFICIENCY = $\frac{a}{a+b} \times 100$																															
DAY OF MONTH		1	2	3	4	5	6	7	8	9	10	11	12	13	14	15	16	17	18	19	20	21	22	23	24	25	26	27	28	29	30	31	
TOTAL CORRECT ALERTS		6	6	6	20	6	5			11	11	6	6	6	6	18	5	5	5	6	9	6	6	6	6	6	6	6	6	6	6	6	6
TOTAL FALSE/MISSED ALERTS		0	0	0	5	0	1			1	1	0	0	0	4	1	1	1	0	1	0	0	0	0	0	0	0	0	0	0	0	0	0

Figure 3-3. Sample completed DA Form 3992-R—Continued

Chapter 4 Controlled Substances Training Aids

4-1. General

The effectiveness of narcotics/contraband detector dogs depends on continual reinforcement of the detection skill through proficiency training.

a. Army installations located within the States or territories of the United States that are assigned narcotics/contraband detector dogs are required to register with the Drug Enforcement Administration (DEA), U.S. Department of Justice, before obtaining controlled substance training aids from any source. Possession and/or use of controlled substance training aids by Army installations or activities not registered with DEA is prohibited by law. Proof of registration is possession of a current registration certificate DEA Form 223 (Controlled Substances Registration Certificate). An Army research protocol filed with the DEA is the document that allows installations or activities identified in the protocol to apply for registration, and to then procure, store, and use controlled substance training aids in proficiency training. (See section 33, part 1301, title 21, Code of Federal Regulations (21 CFR 1301.33).)

b. Army units or installations located outside the States or territories of the United States are not required or eligible to register with DEA. DEA controlled substance training aids are not available to overseas units. Overseas units will coordinate all activities involving the use of controlled substances for training with their respective host government(s). Consistent with host country agreements, controlled substance training aids may be obtained from US Army Criminal Investigation Command (CID) or MP evidence custodians in accordance with AR 195-5. Security, control, accountability, use, and destruction of training aids obtained from CID or MP evidence custodians will be as prescribed in this chapter.

c. The requirements stated in this chapter are derived from section 801, title 21, United States Code (Controlled Substances Act) (21 USC 801) as published in part 1301, title 21, Code of Federal Regulations (21 CFR 1301). Current copies of 21 CFR 1301 should be on hand in each unit registered with DEA. Units may obtain copies through their installation library or directly from the Superintendent of Documents, US Government Printing Office, Washington, DC 20402; commercial telephone (202) 783-3238. The CFR is revised annually as of 1 April. The numbers and letters in parentheses at the end of some paragraphs in this chapter are references to paragraphs in the CFR. Questions concerning these requirements may be directed to the Compliance Division of the local DEA Field Division/Resident Officer. DEA Field Divisions, District and Resident offices, are listed in figure 4-1 and a map showing these elements is provided in figure 4-2.

4-2. DEA registration

The Army research protocol is the only protocol required for registration. Installation PMs or security officers are not required to submit a protocol to DEA with their registration application. However, the transmittal letter should make reference to the Army research protocol on file at Headquarters, DEA, which covers the Army narcotics/contraband detector dog program. DEA registration for authority to procure and use controlled substance training aids (marihuana, hashish, heroin, and cocaine) will be accomplished as follows:

a. Registration for heroin, hashish, and marihuana (Schedule I). Complete DEA Form 225 (New Application for Registration Under Controlled Substances Act of 1970). The form is completed according to the instructions printed therein. A sample DEA Form 225 - Schedule I at figure 4-3 also may be used as a guide. The individual assigned direct responsibility for control and safe keeping of controlled substance training aids will sign the DEA Form 225 as the applicant. This normally will be the installation PM or security officer or his designee. A custodian and an alternate custodian should be appointed in writing to handle the daily responsibility for controlled substances (21 CFR 1301.32).

b. Registration for cocaine (Schedule II). A separate DEA Form 225 must be submitted to obtain DEA registration for cocaine. A separate form is required because cocaine is classified in a different schedule. The form is completed according to the instructions printed therein. A sample DEA Form 225 - Schedule II at figure 4-4 also may be used as a guide (21 CFR 1301.32).

c. Address. Send the original completed DEA Form(s) 225 to the Registration Branch, Drug Enforcement Administration, Department of Justice, P.O. Box 28083, Central Station, Washington, DC 20005; and a copy to the major Army command under whose jurisdiction the installation falls (21 CFR 1301.32 (c)).

d. DEA responsibilities. When the application is approved, DEA will issue a DEA Form 223 (Controlled Substances Registration Certificate). DEA may assign a single registration number to both Schedule I and II substances rather than issuing two registration certificates. This does not change the requirement to submit separate applications. The registration certificate authorizes the applicant from the registered installation/activity to procure, store, and use controlled substance training aids for narcotics/contraband detector dog proficiency training. No other personnel are required to register. The Controlled Substances Act authorizes any Federal officer engaged in the enforcement of any Federal law relating to controlled substances, drugs, or customs to possess controlled substances in the course of his or her duties (21 CFR 1301.26 and 1301.44).

e. Renewals. The registration certificate normally will be valid for one year. Approximately 60 days prior to the expiration date, a preprinted DEA Form 225a (Renewal Application for Registration) will be sent to each registrant by DEA. If DEA Form 225a has not been received within 45 days prior to the expiration date, notify the appropriate DEA regional office. DEA Form 225a will be used following the same procedures for completion of DEA Form 225 to reregister. Copies of renewal registration certificates will be sent to the appropriate MACOM as required in *c* above (21 CFR 1301.32 (c)).

f. Changes. If, during the period of registration, changes occur which modify any information contained on the original DEA Forms 225 or 225a, a certified letter identifying the changes will be sent to the Registration Branch, Drug Enforcement Administration, Department of Justice, PO Box 28083, Central Station, Washington, DC 20005. The letter will include the registrant's name, address, and registration number(s) that are printed on the current certificate of registration, and the new or modified information. The letter is processed by DEA in the same manner as a new application. When approved, DEA will issue a new certificate of registration which will be maintained with the old certificate of registration until expiration. Copies of new registration certificates will be sent to the appropriate MACOM as required in *c* above (21 CFR 1301.61).

4-3. Procurement of training aids

Each installation or activity with assigned narcotics/contraband detector dogs that is registered with DEA is authorized to procure controlled substance training aids. Maximum amounts permitted in a procurement action are up to 20 grams of cocaine, up to 20 grams of heroin, up to 20 grams of hashish, and up to 200 grams of marihuana. The maximum quantities of controlled substances authorized to be on hand at any one time are 300 grams of marihuana, 30 grams of hashish, 30 grams of heroin, and 30 grams of cocaine. This "extra" amount is authorized only when "old" training aids are being destroyed and "fresh" controlled substances are being issued.

a. DEA supplies bulk quantities of marihuana, hashish, heroin, and cocaine to the US Air Force Security Police Academy, 341st Military Working Dog Training Squadron. Upon receipt of bulk shipments from DEA, the 341st Military Working Dog Training Squadron has the substances qualitatively analyzed if this information is not provided by DEA. The substances are weighed and packaged into appropriate quantities for shipment as training aids to registered units or installations.

b. Individual units possessing a current certificate of registration DEA Form 223 will order training aids as required by submitting DEA Form 222 (DEA Official Order Form for Schedule I and II Controlled Substances). Supplies of these preprinted order forms will be provided by DEA when the registration certificate is issued. The DEA Form 222 is controlled and a sample is not included with this pamphlet. However, the form is easy to complete using the following guidance:

- (1) *Supplier's name.* 341st Military Working Dog Training Squadron.
- (2) *Supplier's address (city and State).* Lackland AFB, TX 78236.
- (3) *Street address.* Leave blank.
- (4) *Date block.* Leave blank.
- (5) *Packaging.* Heroin, hashish, and cocaine training aids are packaged in 20-gram containers. Marihuana is packaged in a 200-gram container. Orders should state the same quantities of these substances as follows:
 - (a) Line item 1: one package, size of package: 200 grams, marihuana.
 - (b) Line item 2: one package, size of package: 20 grams, hashish.
 - (c) Line item 3: one package, size of package: 20 grams, heroin.
 - (d) Line item 4: one package, size of package: 20 grams, cocaine.
- (6) *Name and address of registrant block.* The installation or activity already should be identified in this block when the forms are obtained from DEA.
- (7) *Signature of purchaser or his attorney or agent.* Enter the typed name, rank, title, and signature of the responsible individual who signed the DEA Form 225 or 225a as applicant. (See para 4-2.)

c. Mail copies one and two to Commander, 341st Military Working Dog Training Squadron, Lackland AFB, TX 78236. Keep copy three for your files. National Drug Codes are used by DEA on the DEA Form 225/225a and the unit may wish to add this information to its file copy of DEA Form 222. Drug codes on copies one and two of DEA Form 222 are filled in by the supplier.

d. The 341st Military Working Dog Training Squadron will fill the order and record the number of containers of each substance furnished and the date the containers are shipped to you on copies one and two of the order form. The substances can only be shipped to the location preprinted on the order form. The 341st Military Working Dog Training Squadron will keep copy one of the order form for its records and will forward copy two to the DEA at the end of the month in which the order was filled. The 341st Military Working Dog Training Squadron will include a qualitative analysis statement for each line item in the shipment.

e. When the requested shipment is received, the appointed custodian will verify the weight of each container and record, on copy three of the order form, the weight of each container received and the date received. Controlled substance training aids will be stored and controlled as required by this chapter.

f. Any order form which is not complete, legible, properly prepared, properly signed, or shows any signs of

alteration or erasure will not be accepted by the supplier (1). Unaccepted forms are returned to the installation or activity with a statement explaining the reason(s) the form was not accepted. Copies one and two of the unaccepted forms and the statement explaining nonacceptance will be filed with the retained copy three and maintained for a period of at least two years. A defective order form may not be corrected. A new order form must be initiated (21 CFR 1305.11).

4-4. Controlled substances accountability folder

A controlled substances accountability folder will be kept for each separate controlled substance training aid shipment from the supplier. A new folder is started whenever a new DEA Form 222 is initiated. Similarly, a folder will be started for each issue of controlled substances from a CID or MP evidence custodian.

a. When a new training aids shipment is requested, copy three of the DEA Form 222 is the first document filed in the folder. A copy is made of copy three DEA Form 222 for each additional control substance folder as needed. For controlled substances requested and obtained from CID or MP evidence custodians, a copy of the request and DA Form 4137 (Evidence/Property Custody Document) on which the controlled substances are accepted are the first documents filed in the folder.

b. When controlled substances are received, the appointed controlled substance training aids custodian (or alternate) first weighs each container to verify the quantity of substances being received. Any discrepancies should be immediately reported to the issuing agency. Any theft or unexplained loss should be reported and investigated according to the criteria in paragraph 4-6e. For DEA training aids, annotate copy three of the DEA Form 222 in the space provided with the number of containers of each substance received, the weight of each container, and the date received. Separate .5 gram each of heroin and cocaine and preserve separately for analysis. When this is done, the custodian may repack the substances into other types of containers and in various quantities, if desired. Do not mix controlled substances with each other or with other substances when repackaging training aids. Qualitative integrity of the controlled substances must be maintained.

c. Controlled substance training aids/containers will be identified using a three-number code with hyphens between the numbers, for example, 1-3-4.

(1) The first number indicates the order in which the controlled substances were received by the using installation or activity. For example, 1-3-4 would indicate the training aid/container is from the first shipment of DEA controlled substances received from the 341st Military Working Dog Training Squadron. Numbers will be assigned sequentially beginning with one and will continue indefinitely without interruption, duplication, or consideration for changing years.

(2) The second number indicates the container in the shipment from the 341st Military Working Dog Training Squadron or in the issue from an MP or CID evidence custodian from which the training aid was taken. If only one container of a controlled substance is received in a shipment or issue, all training aids taken from the container will have the same middle number. If one container of marihuana and one container of heroin are received, they will be identified as number one and two in the sequence they appear on the DEA Form 222 or DA Form 4137. The DEA Form 222 (or DA Form 4137) will be annotated with this identifying number for each container when the weight of the controlled substances received is verified according to the procedure in b, above. For example, 1-3-4 would indicate that the training aid came from the third container in the first shipment received from Lackland AFB by the installation or activity.

(3) A third and final number in the three-number code identifies a specific training aid. Each portion or container which results from the subdividing or repackaging of an original container of controlled substances received from any source will be assigned a sequential number beginning with the number one. For example, training aid/container 1-3-4 is the fourth training aid repackaged out of the third original container, received in the first controlled substance shipment from the 341st Military Working Dog Training Squadron.

(4) The three-part number, then, represents the issue or shipment sequence number, the original line item number from the DEA Form 222 or DA Form 4137 used to issue the controlled substances, and the training aid number. For example, in your first shipment of controlled substances you received heroin and marihuana which were line items number one and two on DEA Form 222. When you repackaged the substances to make training aids, you made three heroin training aids and seven marihuana training aids. Your heroin training aid containers would be numbered 1-1-1, 1-1-2, and 1-1-3. Your marihuana training aid containers would be numbered 1-2-1, 1-2-2, 1-2-3, 1-2-4, 1-2-5, 1-2-6, and 1-2-7.

d. Each controlled substance training aid/container will be assigned its own unique training aid/container number, and each will be individually weighed. This information will be recorded on DA Form 4608-R (Controlled Substances Accountability Record). An example of a completed DA Form 4608-R is provided in figure 4-5. All controlled substances received will be accounted for on the DA Form 4608-R. A new DA Form 4608-R will be initiated each time new controlled substances are received and will be maintained in the controlled substances accountability folder. Disposition of all training aids/containers will be recorded in the "Remarks" column.

e. Controlled substance containers/training aids will be signed out, and signed back in by the custodian whenever they are removed from secure storage for training or for any other reason. The DA Form 4607-R (Controlled Substance Training Aid Utilization Record) will be used for this purpose. One DA Form 4607-R will be used for each training aid/container. The DA Form 4607-R will be maintained with the training aid/container until final disposition.

When final disposition is made, the method of destruction or disposal will be recorded on the form including the date, witnesses, and any other appropriate information. The completed DA Form 4607–R will be filed in the controlled substances accountability folder along with any associated documents. Figures 4–6 and 4–7 provide examples of properly completed DA Forms 4607–R, correctly cross–referenced with the sample DA Form 4608–R at figure 4–5 and 4–8.

f. Controlled substances accountability folders will be retained in active secure files for at least 2 years after the date of the last action affecting any training aid that was taken from the controlled substances to which the folder pertains. Because portions of each shipment or issue of controlled substances may become unusable and be disposed of at different times, several DA Forms 4607–R and 4608–R, DEA Forms 41 (Registrant’s Inventory of Drugs Surrendered), letters of disposition instructions, and letters of notification of disposition may be filed in the accountability folder. These records are subject to inspection by the Department of Justice, the DEA, the commander, the PM, the inspector general, or by any representative of these agencies or individuals who has been appointed or authorized to conduct inspections or investigations (21 CFR 1316.03).

4–5. Destruction of training aids

a. Destruction of training aids, for any reason, which were procured from the 341st Military Working Dog Training Squadron will be accomplished as follows:

(1) Store all controlled substances or packaging determined to be unusable physically separate from usable controlled substances. Each package of unusable controlled substance/package will be marked clearly as unusable.

(2) Submit a letter to the appropriate DEA office requesting disposition instructions for controlled substances to be destroyed. The letter must list the type and quantity of all the drugs scheduled for destruction. The DEA Division or District Administrator will furnish instructions for proper disposal of substances. Complete DEA Form 41 and submit three copies to the DEA office. Insert one copy for each type of substance destroyed into the respective control substance accountability folder. Copies of the DEA letter of disposition instructions are also to be filed in the accountability folders. DEA Form 41 is available on request from DEA offices (21 CFR 1307.21).

b. Destruction of controlled substance training aids and packaging obtained from CID or MP evidence custodians will be accomplished as follows:

(1) When all or part of a controlled substance training aid is determined to be of no further value for training, it will be destroyed in the presence of a witness (SFC/E7 or above) using an approved method of destruction (for example, marijuana may be destroyed by burning).

(2) Appropriate entries will be made on all accountability documents, including the DA Form 4137, noting the following:

- (*a*) Date.
- (*b*) Time.
- (*c*) Location of the destruction.
- (*d*) The identity of the person performing the destruction.
- (*e*) The identity of all witnesses to the destruction.

(3) Accountability documents will be retained in active secure files for at least two years after the date of destruction of all the training aids that were taken from the original amount of controlled substances issued on DA Form 4137.

4–6. Security requirements

Strict physical security and control procedures must be applied to prevent the misuse or theft of controlled substances used as training aids obtained from any source. All installations or activities using controlled substance training aids will comply with the following minimum security and control requirements (21 CFR 1301.72):

a. Storage location. Controlled substance training aids will be stored in a location meeting the minimum criteria shown below.

(1) Buildings and rooms will meet or exceed the minimum structural standards specified for secure storage structures in AR 190–51.

(2) The door(s) to the room in which controlled substance training aids are stored will be secured using approved locking devices. Lightweight doors will be replaced with solid metal or wood doors, or covered with 9–gauge to 12–gauge security screen or 16–gauge sheet steel. They will be fastened with smooth–headed bolts and nuts, and peened in place.

(3) All windows providing access to a storage room that is not staffed 24 hours a day will be protected by a 9–gauge to 12–gauge security screen, or 3/8–inch or larger diameter steel bars spaced no more than 6 inches apart. The frames holding the screen or bars must be fastened to the window frame with smooth–headed bolts.

b. Storage containers.

(1) Controlled substance training aids will be secured in a Class 5, General Services Administration–approved security container equipped with approved 3 position combination locks. If the security container weighs less than 750 pounds, it will be bolted, chained, or cemented to the floor or wall in such a way that it cannot be readily removed.

(2) Heroin, cocaine, hashish, and marihuana will each be stored in a separate area, drawer, or container within the security container to prevent cross-contamination of the individual odor characteristics of each substance. Marihuana has a very strong scent and is the most likely substance to cause an odor cross-contamination problem.

c. IDS. The security container should be protected by an approved IDS connected to a central monitoring station, with personnel on 24-hour duty who can provide an armed response to an alarm signal. When IDS is used, it will be installed to protect the storage container as well as the doors and windows to the storage room for unauthorized entry. The decision whether to install IDS is based on:

- (1) A thorough risk analysis considering the security threats.
- (2) The location of the storage facility.
- (3) The structural integrity of the building and room in which the storage container is located.
- (4) The quantity of drugs being stored.
- (5) The relative cost of compensatory measures necessary to provide security equivalent to an IDS.

d. Access control. The controlled substances storage area shall be accessible to an absolute minimum number of specifically authorized personnel (21 CFR 1301.72(d)).

(1) Access to the controlled substance storage room will be limited to the primary and alternate custodians, and a very limited number of other individuals. These are persons who will require access for official purposes. They are to be specifically identified in writing by the PM or security officer. A copy of access authorizations will be maintained on file in the storage area, but will not be posted in the area or on the container.

(2) SF 702 (Security Container Checklist) will be used to record all openings and closings of the storage container. SF 702 will be posted on the container. The completed SF 702 will be retained for 30 days from the date of the last entry on the form and will then be destroyed unless needed for an investigation.

(3) The doors to the storage area will always be locked unless authorized personnel are physically present and have direct observation of the storage container.

(4) During normal duty hours or at other times when the storage room has been authorized to be open, unauthorized personnel will not be allowed to enter the storage room. The storage container will not be opened except to issue, inventory, repackage, or return controlled substance training aids, or to perform other necessary and authorized functions. At all other times, the storage container will be secured.

e. Weight checks.

(1) Each container of controlled substances will be weighed monthly and verified by a disinterested person (E7 or above) who will certify the exact weight of each controlled substance training aid/container in grams. The Trip Balance Laboratory, NSN 6670-00-401-7195, one of which is authorized by CTA 8-100, for each military police unit with narcotics/contraband detector dogs authorized, may be used for this purpose. Monthly weight checks will be recorded on a separate DA Form 4608-R for each training aid/container. Completed weight check forms will be filed in the controlled substances accountability folder. A sample completed form is provided at figure 4-8.

(2) Minor weight variation because of irretrievable loss resulting from breakage of training aids during dog team training exercises or any unexplained or suspicious loss of more than one gram of heroin, cocaine, or hashish, or two grams of marihuana will be reported immediately to the PM or security officer. An immediate investigation will be conducted. One copy of the report of investigation will be sent to HQDA(DAMO-ODL-S), 400 Army Pentagon, Washington, DC 20310-0400, and one copy will be sent to the appropriate MACOM PM or security officer. One copy of the investigation report will also be filed in the controlled substances accountability folders.

(3) Any theft or significant loss (one gram or more of heroin, cocaine, or hashish; and 2 grams or more of marihuana) of any controlled substance obtained from the 341st Military Working Dog Training Squadron will be reported immediately to the appropriate DEA Field Division or Resident Office upon discovery of such theft or loss. DEA Form 106 (Report of Theft or Loss of Controlled Substances) will be used. Thefts must be reported whether or not the controlled substances are subsequently recovered and/or the responsible parties are identified and action taken against them (21 CFR 1301.74(c)). A copy of the completed DEA Form 106 will be attached to each of the copies of the report of investigation required for distribution in compliance with the requirement of (2) above.

f. Inventories.

(1) Inventories will be made:

- (a) Once during each calendar quarter.
- (b) When a new primary controlled substance training aid custodian is appointed.
- (c) When any controlled substances are lost from storage, or when there has been a breach in security of the storage room or storage container.

(2) Quarterly inventories will be made by a disinterested person (anyone not assigned to or with direct responsibility for the installation MWD program) in grade E7 or above, who is appointed by the PM or security officer, or installation or activity commander. Inventories which are required because of losses or breaches of security will also be conducted by a disinterested person.

(3) Change of primary custodian inventories will be joint inventories between the old and new custodian.

(4) An inventory will completely account for all quantities of controlled substances maintained as training aids and

will be a complete audit of the accountability records pertaining to those substances. Only those records that are still active and those that have not been previously audited need to be audited. The person conducting the inventory will positively account for all quantities and types of substances by verifying the audit trail set up by the DEA Form 222 (or DA Form 4137), DA Forms 4608-R, DEA Forms 41 (or destruction certificates), and the amount of the substances on hand.

(5) The person conducting the inventory will prepare a report for the PM or security officer, or other appointing authority. A copy of the report will be maintained with the controlled substances accountability folders in a secure files storage area. Inventory reports will be maintained for at least two years from the date of the report (21 CFR 1304.04).

(6) Inventory reports will include the following information:

(a) Date of inventory and the inclusive dates of all controlled substances accountability records included in the inventory.

(b) Name, rank, and unit of the person conducting the inventory. Include a copy of any written appointing document for disinterested persons or the appointing document for a new primary custodian.

(c) Quantity of each type of controlled substance ordered and received (from DEA Form 222 and/or DA Form 4137 in controlled substances accountability folders).

(d) Quantities of each type of substances disposed of (from DEA Forms 41 or other documents validating authorized disposition).

(e) Quantities of each substance on hand or in use.

(f) State whether the inventory and audit of records successfully accounted for all controlled substances. If all substances could not be accounted for, state what action was taken to resolve the discrepancies and any recommendations to improve accountability procedures.

(g) Evaluate the custodian's compliance with security, accountability, and control procedures.

4-7. Control of issue, return, and use

a. Issue or return procedures.

(1) Personnel authorized to sign out, possess, and use controlled substance training aids to conduct proficiency training will be designated in writing by the PM or security officer (21 CFR 1301.90).

(2) DA Form 4607-R will be used to maintain a record of all issues and turn-ins of training aids as discussed in paragraph 4-4e.

(3) When training aids are issued, the date, time of issue, training aid/container number, location where training is to be conducted, and the signature of the person receiving the training aids will be recorded on the form.

(4) When returned, the date, time of return, and the signature of the custodian receiving the aids will be recorded on the form along with any appropriate remarks.

(5) Training aids will be issued, returned, and secured during the same duty day, unless special authorization to do otherwise is granted in advance by the PM or security officer.

b. Control of training aids during use.

(1) All personnel authorized to conduct training using controlled substance training aids will be thoroughly briefed on the security requirements and personal responsibility for controlled substances before being allowed to participate in training. Briefings will be conducted at least annually thereafter. A written record for these briefings will be made and will be maintained on file.

(2) The person who was issued and is using controlled substance training aids for training is responsible for the control and security of the training aids. This person will not leave the immediate area where training aids are being used, and is responsible for retrieving and returning all training aids to the custodian.

(3) Unauthorized personnel will not be allowed to handle training aids. However, different authorized personnel should be involved in placing training aids rather than the same person, so that the dog genuinely responds on the training aids rather than the scent of the person placing the training aids (21 CFR 1301.90).

c. Temporary duty control procedures. Qualified narcotics/contraband detector dog handlers may be authorized to carry training aids when deployed TDY if the period of TDY exceeds five working days. Training aids which are authorized for use while TDY will be controlled as follows:

(1) The handler's TDY orders will specifically authorize the handler to possess the type and quantity of controlled substance training aids being carried.

(2) When the training aids are not in use at the TDY location, the training aids will be secured in a container that meets or exceeds the requirements of paragraph 4-6b. The container will be located in a secure storage room or area protected by IDS, or in a room or area which is always occupied by armed military or security police personnel.

(3) DA Form 4137 will be used for issue from and turn-in to the TDY storage location, and to provide a continuous chain of custody record for the controlled substance training aids while the handler is TDY. The TDY handler is the only person authorized to receive the training aids being stored at the TDY location.

(4) If the dog handler must unavoidably interrupt travel between his or her home station and TDY location overnight, the handler will contact the nearest military installation PM or security officer, or the local civilian police

agency, and request that the agency secure the training aids. A written receipt (DA Form 4137 may be used) for the training aids will be obtained when the training aids are surrendered by the handler for safekeeping.

(5) Training aids procured from the 341st Military Working Dog Training Squadron will not be transported outside the State or territories of the United States. Training aids obtained from CID or MP evidence custodians will also not be transported outside the geographic and jurisdictional boundaries of the host country, except as permitted by law, and by prior coordination with and the written consent of, any country involved. Transportation of training aids within the geographic and jurisdictional boundaries of host country is subject to the laws and coordinated agreements with the host government.

4-8. Form procurement and control

a. DEA forms.

(1) DEA Form 225 and other noncontrolled blank DEA forms may be obtained at any Field Division of the DEA, or by writing to the Registration Branch, Drug Enforcement Administration, Department of Justice, PO Box 28083, Central Station, Washington, DC 20005.

(2) DEA Form 225a will be mailed to each registered person approximately 60 days before the expiration date of the current registration. If DEA Form 225a has not been received within 45 days before the expiration date of the current registration, request DEA Form 225a by writing to the DEA Registration Branch at the address given above.

(3) Blank DEA order forms (DEA Form 222) are controlled and are issued with the DEA registration certificate. Reproduction of blank DEA order forms is prohibited (21 CFR 1305.05).

(4) DEA Form 223 is issued by DEA when the application for registration is approved.

(5) DEA Form 223 and DEA Form 222 will be secured in a locked security container under the immediate control of the PM or security officer, or of the individual whose signature is on the application for registration (DEA Form 225 or 225a) as the applicant. DEA Forms 223 and blank DEA Forms 222 will be secured separately from the controlled substance training aids/containers and the controlled substances accountability folders. DEA Form 223 and blank DEA Forms 222 will be inventoried at least quarterly by the applicant.

b. DA forms. DA Form 4607-R and DA Form 4608-R may be reproduced locally. Copies for reproduction purposes are located at the back of this book.

4-9. Use of synthetic drug training aids

a. The use of pseudo-cocaine or pseudo-heroin substances to train narcotics/contraband detector dogs is prohibited. No controlled scientific studies have been conducted by competent scientists which prove drug substitutes will adequately simulate the real drug. The use of real cocaine and heroin to train dogs to detect and respond avoids detection problems caused by the perfume effect (a substance mixed with splicing materials can produce a new odor). It also avoids real odor concentration problems (substitutes may not emit the same odor concentration as the real drug).

b. The use of pseudo-drugs to train detector dogs can be compared to the problem created when a dog that is trained to detect marihuana is assumed to be able to detect hashish. Although both substances contain tetrahydrocannabinol (THC), the THC exists in different concentrations. A dog trained to detect marihuana may not respond on hashish because of this difference. A properly trained dog is therefore trained to detect and respond on both marihuana and hashish.

c. To maintain the proficiency of narcotics/contraband detector dog teams, real marihuana, hashish, heroin, and cocaine training aids will be obtained and used in both training and actual searches.

ATLANTA FIELD DIVISION¹

Suite 200, United Family Life Bldg., 200 Houston St., N.E., Atlanta, Georgia 30303; 242-4401

Charleston Resident Office, Room 630, 334 Meeting St., Charleston, South Carolina 29403; 930-5209

Columbia Resident Office, Room 204, 1101 Laurel, P.O. Box 702, Columbia, South Carolina 29202; 677-5251

Columbus Resident Office, P.O. Box 1565, Columbus, Georgia 31902; 247-9787

Greensboro Resident Office, 2300 W. Meadowview Road, Suite 224, Greensboro, North Carolina 27407; 699-5203

Figure 4-1. DEA field divisions and district/resident offices (Office, Address, and Telephone)

Memphis Resident Office, 401 Federal Bldg., 167 N. Main St., Memphis, Tennessee 381031; 222-3396
Nashville Resident Office, A929, Estes Ke Fauver Bldg., FB-USCH, 801 Broadway, Nashville, Tennessee 37203 1; 852-5988
Savannah Resident Office, Suite C, 430 Mall Blvd., Savannah, Georgia 31406; 248-4288
Wilmington Resident Office, P.O. Box 4189, Wilmington, North Carolina 28406; 671-4513

BOSTON FIELD DIVISION ¹

G-64 JFK Federal Bldg., Boston, Massachusetts 02203; 223-2170
Bridgeport Resident Office, FB-USCH, 915 Lafayette Blvd., Bridgeport, Connecticut 06604; 643-4591
Burlington Resident Office, P.O. Box 327, Essex Junction, Vermont 05452; 832-6777
Concord Resident Office, Federal Bldg. & P.O., 55 Pleasant St., P.O. Box 1314, Concord, New Hampshire 03301; 834-4754
Hartford Resident Office, Room 628, 450 Main St., Hartford, Connecticut 06103; 244-3230
Portland Resident Office, 329 USCH Bldg., 156 Federal St., P.O. Box 451, Portland, Maine 04101; 833-3331
Providence Resident Office, 232 P.O. & Federal Bldg., Exchange Terrace, Providence, Rhode Island 02903; 838-4322
Springfield Resident Office, 1550 Main St., Rm. 408, Springfield, Massachusetts 01103; 836-9284

CHICAGO FIELD DIVISION ¹

1800 Dirksen Federal Bldg., 219 S. Dearborn St., Chicago, Illinois 60604; 353-7875
Fargo Resident Office, Room 257, 657 2nd N. Ave., Fargo, North Dakota 58102; 783-5331
Hammond Resident Office, 407 Federal Bldg., 507 Slate St., Hammond, Indiana 46302; 370-5321
Indianapolis Resident Office, Room 290, 575 N., Pennsylvania, Indianapolis, Indiana 462041; 331-7977
Milwaukee Resident Office, 228A FB-USCH, 517 E. Wisconsin, Milwaukee, Wisconsin 53202; 362-3395
Minneapolis Resident Office, 402 Federal Bldg., 110 S. 4th St., Minneapolis, Minnesota 55401; 725-2783

DALLAS FIELD DIVISION ¹

1880 Regal Row, Dallas, Texas 73235; 729-7151
Ft. Worth Resident Office, P.O. Box 17478, Ft. Worth, Texas 76102; 334-3455
Oklahoma City Resident Office, Federal Bldg., 200 N.W. Fifth St., Suite 960, Oklahoma City, Oklahoma 73102; 736-4141
Tulsa Resident Office, 333 W. Fourth St., Rm. 3335, Tulsa, Oklahoma 74103; 736-7611
El Paso District Office, 4110 Rio Bravo, Suite 100, El Paso, Texas 79902; 572-7920
Alpine Resident Office, P.O. Box 1282, Alpine, Texas 79830; 8-915-837-3421
Lubbock Resident Office, 1605 Broadway, Lubbock, Texas 79403; 738-7344

DENVER FIELD DIVISION ¹

316 U.S. Customs House, P.O. Box 1860, Denver, Colorado 80201; 327-3951
Cheyenne Resident Office, 8020 Federal Center, 2120 Capitol Ave., Cheyenne, Wyoming 82001; 328-2391
Salt Lake City Resident Office, 8416 Federal Bldg., 125 State St., Salt Lake City, Utah 84138; 588-4156
Albuquerque District Office, 1st National Bank Bldg., East 5301 Central Ave., N.E., Albuquerque, New Mexico 87108; 474-3285
Las Cruces Resident Office, P.O. Box 399, Las Cruces, New Mexico 88004; 571-8337

DETROIT FIELD DIVISION ¹

357 Federal Bldg., 231 W. Lafayette, Detroit, Michigan 48226; 226-7290
Cincinnati Resident Office, 7405 Federal Office Bldg., 550 Main St., Cincinnati, Ohio 45201; 684-3671
Cleveland Resident Office, Room 300, 601 Rockwell, Cleveland, Ohio 441141

HOUSTON FIELD DIVISION ¹

4299 San Felipe, Suite 200, Houston, Texas 77027; 526-4950
Corpus Christi Resident Office, 723 Upper North Broadway, P.O. Box 2443, Corpus Christi, Texas 78403; 734-3236
Galveston Resident Office, P.O. Box 2070, Galveston, Texas 77553; 527-6565
McAllen District Office, 3017 S. 10th St., McAllen, Texas 78501; 734-4562
Brownsville Resident Office, 2100 Boca Chica Blvd., Suite 305, Brownsville, Texas 78521; 734-8253
Laredo Resident Office, P.O. Drawer 2307, Laredo, Texas 78041; 734-6211
San Antonio District Office, 4th Floor, 1800 Central Bldg., 1802 N.E. Loop 410, San Antonio, Texas 78217; 730-5050
Austin Resident Office, 55 N. Interregional Hwy., P.O. Box 8, Austin, Texas 78767; 770-5631
Del Rio Resident Office, 132 Foster Drive, Del Rio, Texas 78840; 730-7241

Figure 4-1. DEA field divisions and district/resident offices (Office, Address, and Telephone)—Continued

Eagle Pass Resident Office, 342 Rio Grande, Room 102, Eagle Pass, Texas 78852; 730-7236

LOS ANGELES FIELD DIVISION ¹

Suite 800, 350 S. Figueroa St., Los Angeles, California 90071; 798-2650
Honolulu Resident Office, Room 3129, 300 Ala Moana Blvd., P.O. Box 50163, Honolulu, Hawaii 96850; 8-808-546-8391
Guam Resident Office, Suite 502C, 238 O'Hare St., P.O. Box 2137, Agana, Guam 96910; 9-011-671-472-7384
Las Vegas Resident Office, FB-USCH, 300 Las Vegas Blvd. S., P.O. Box 16023 Las Vegas, Nevada 89101; 598-6635
Reno Resident Office, 209 Bldg. 1, 4600 Kietzke Lane, Reno, Nevada 89502; 470-5617

MIAMI FIELD DIVISION ¹

8400 N.W., 53rd St., Miami, Florida 33166; 820-4870
Ft. Myers Resident Office, 2345 Union St., Suite D, Ft. Myers, Florida 33901; 826-3744/54
Jacksonville Resident Office, Suite 210, 4077 Woodcock Dr., Jacksonville, Florida 32207; 946-3566
Orlando Resident Office, 235 Whooping Loop, Altomonte Springs, Florida 32701; 820-6155
Panama City Resident Office, P.O. Box 1486, Panama City, Florida 32401; 946-5217
Tampa Resident Office, Suite 400, 700 Twiggs St., Tampa, Florida 33602; 826-2178
Ft. Lauderdale Resident Office, FB-USCH, 299 E. Broward Blvd., Ft. Lauderdale, Florida 33301; 820-7220
Marathon Resident Office, Room 215, 11400 Overseas Hwy., P.O. Box 1269, Marathon, Florida 33050; 350-5483
West Palm Beach Resident Office, Room 223, 701 Clematis St., West Palm Beach, Florida 33401; 350-7263
Tampa Airport Detail, Tampa, Florida 33401; 826-2176
San Juan District Office, 154 Housing Investment Bldg., 416 Ponce de Leon Ave., Hato Rey, Puerto Rico 00919; 8-809-754-6450

NEWARK FIELD DIVISION ¹

Federal Office Bldg., 90 Broad St., Newark, New Jersey 07102; 341-6060
Atlantic City Resident Office, P.O. Box AB, Northfield, New Jersey 08225; 483-4316

NEW ORLEANS FIELD DIVISION ¹

1661 Canal St., Suite 2200, New Orleans, Louisiana 70112; 682-3894
Baton Rouge Resident Office, Suite 118, 4560 North Blvd., Baton Rouge, Louisiana 70806; 687-0254
Birmingham Resident Office, Suite 520, 236 Goodwin Crest, Birmingham, Alabama 35209; 229-0621
Jackson Resident Office, 1501A Federal Bldg., 100 W. Capitol St., Jackson, Mississippi 39269; 490-4400
Little Rock Resident Office, Suite 850, One Union National Plaza, Little Rock, Arkansas 72201; 740-5981
Mobile Resident Office, Suite 216, 2 Office Park, Mobile, Alabama 36609; 537-2831
Shreveport Resident Office, 8A20A Federal Bldg., Shreveport, Louisiana 71102; 493-5078

NEW YORK FIELD DIVISION ¹

555 W. 57th St., Suite 1900, New York, New York 10019; 662-5151
Albany Resident Office, 746 Leo W. O'Brien Federal Bldg., Clinton Ave. & N. Pearl St., Albany, New York 12207; 562-3425
Buffalo Resident Office, Suite 300, 268 Main St., Buffalo, New York 14202; 437-4421
Rochester Resident Office, P.O. Box 14210, Rochester, New York 14614; 963-3180
Long Island District Office, Suite 1C-02, 1 Huntington Quadrangle, Melville, New York 11747; 667-1777
New York DEA Drug Task Force, Suite 1700, 555 W. 57th St., New York, New York 10019; 662-4991
JFK Airport Station, P.O. Box 361, Jamaica, New York 11430; 667-1666

PHILADELPHIA FIELD DIVISION ¹

10224 William J. Green Federal Bldg., 600 Arch St., Philadelphia, Pennsylvania 19106; 597-9530
Pittsburgh Resident Office, 2306 Federal Bldg., 1000 Liberty Ave., Pittsburgh, Pennsylvania 15222; 722-3390
Wilmington Resident Office, 5305-5307 J. Caleb Boggs Federal Bldg., 844 King St., Wilmington, Delaware 19801; 487-6184

PHOENIX FIELD DIVISION ¹

1980 Valley Bank Center, 201 N. Central, Phoenix, Arizona 85073; 261-4866
Yuma Resident Office, 370 S. Main St., P.O. Box 10151, Yuma, Arizona 85364; 764-6578
Tucson District Office, Tucson International Airport, 6904 South Plumer Ave., Tucson, Arizona 85706; 762-6845
Nogales Resident Office, 3970 Fairway Dr., Nogales, Arizona 85621; 764-1248

Figure 4-1. DEA field divisions and district/resident offices (Office, Address, and Telephone)—Continued

SAN DIEGO FIELD DIVISION ¹

402 W. 35th St., National City, California 90250; 895-5654

Calexico Resident Office, 38 W. 4th St., P.O. Box J, Calexico, California 92231; 894-2446

SAN FRANCISCO FIELD DIVISION ¹

Room 12215, 450 Golden Gate Ave., P.O. Box 36035, San Francisco, California 94102; 556-6771

Fresno Resident Office, Room 104F, 2202 Monterrey St., Fresno, California 93707; 467-5402

Sacramento Resident Office, 2941 B Fulton Ave., P.O. Box 255097, Sacramento, California 95825; 468-4205

San Jose Resident Office, Suite 200, 777 N. 1st St., San Jose, California 95110; 463-7235

SEATTLE FIELD DIVISION ¹

Suite 301, 220 W. Mercer, Seattle, Washington 98119; 399-5443

Anchorage Resident Office, 701 C St., Anchorage, Alaska 99513; 8-907-271-5033

Blaine Resident Office, 170 C St., P.O. Box 1680, Blaine, Washington 98230; 396-9420

Boise Resident Office, 2121 American Reserve Bldg., 2404 Bank Dr., Boise, Idaho 87305; 554-1620

Eugene Resident Office, 230 Federal Bldg., 211 E. 7th Ave., Eugene, Oregon 97401; 425-6861

Great Falls Resident Office, 111 14th St. South, P.O. Box 2887, Great Falls, Montana 59403; 585-1371

Portland Resident Office, 706 Terminal Sales Bldg., 1220 S.W. Morrison, Portland, Oregon 97205; 423-3371

Spokane Resident Office, USCH, 920 W. Riverside, P.O. Box 1504, Spokane, Washington 99201; 439-5342

ST. LOUIS FIELD DIVISION ¹

Suite 200, Chromallory Plaza, 120 S. Central Ave., St. Louis, Missouri 63120; 279-3241

Des Moines Resident Office, USCH, P.O. Box 1784, Des Moines, Iowa 50306; 862-4700

Kansas City Resident Office, Suite 300, 1150 Grand Ave., Kansas City, Missouri 641061; 758-2631

Omaha Resident Office, Federal Bldg., 215 N. 17th St., P.O. Box 661, Downtown Station, Omaha, Nebraska 68101; 864-4222

Sioux Falls Resident Office, P.O. Box 1109, Sioux Falls, South Dakota 57102; 782-4421

Wichita Resident Office, Room 505, 202 W. 1st St., Wichita, Kansas 67202; 752-6601

WASHINGTON D.C. FIELD DIVISION ²

Room 2558, 400 Sixth St., S.W., Washington, D.C. 20024; 724-7834

Charleston Resident Office, 22 Capital St., P.O. Box 1146, Charleston, West Virginia 25324; 930-5209

Norfolk Resident Office, Suite 320, 200 Grandby Mall, Federal Bldg., Norfolk, Virginia 23510; 827-3152

Richmond Resident Office, 400 N. 8th St., P.O. Box 10150, Richmond, Virginia 23240; 925-2871

Baltimore District Office, 955 Federal Bldg., 31 Hopkins Plaza, Baltimore, Maryland 212012; 922-4800

EL PASO INTELLIGENCE CENTER FIELD DIVISION

South 200, 2211 E. Missouri, El Paso, Texas 79903; 572-7942

Notes:

¹ Field Divisions/Resident Offices that can assist in registration matters.

² Assistance capability at Baltimore to be transferred to Washington, DC on a date to be determined.

Figure 4-1. DEA field divisions and district/resident offices (Office, Address, and Telephone)—Continued

U.S. Department of Justice Drug Enforcement Administration

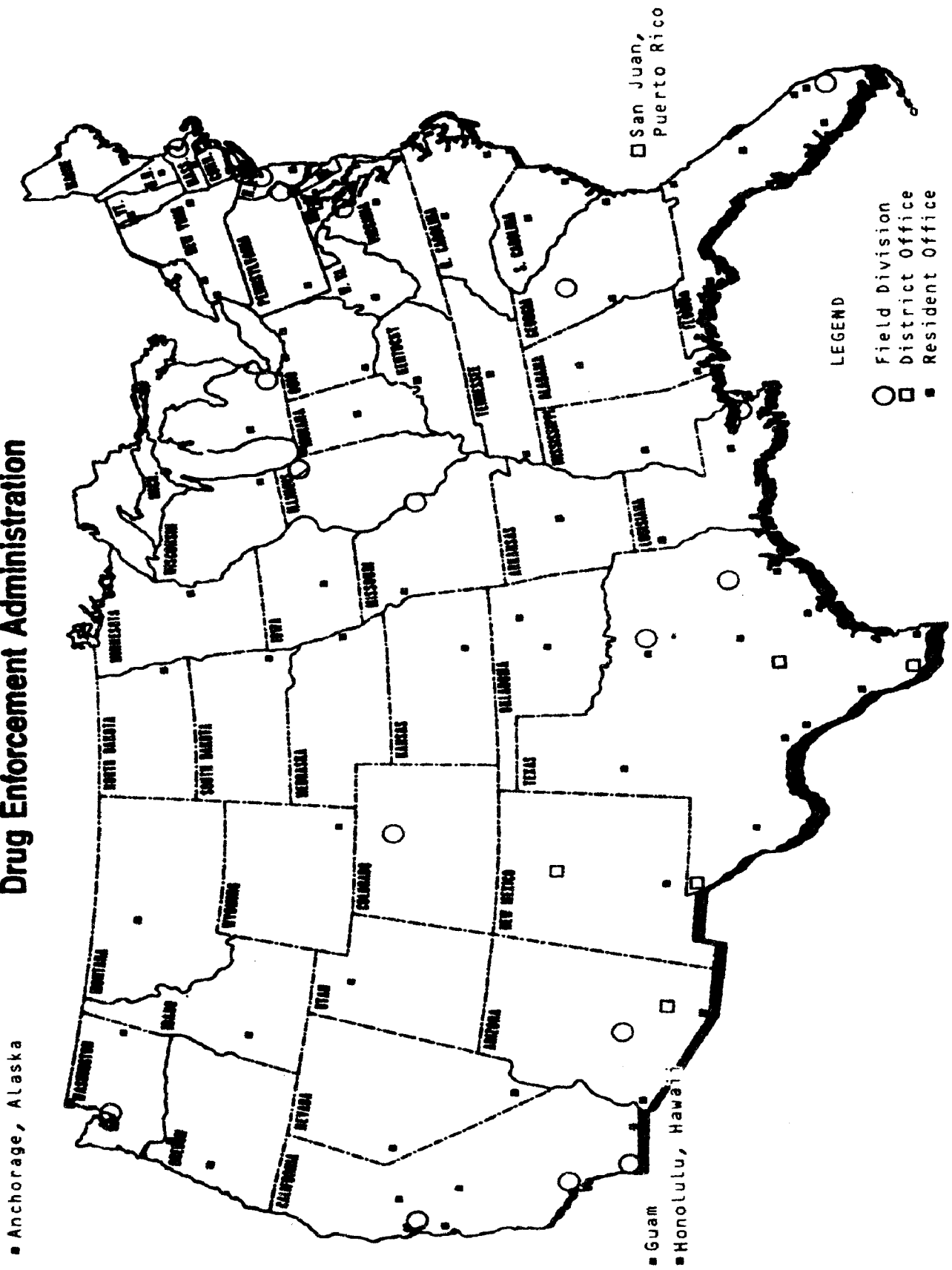

Figure 4-2. DEA field division and district/resident office map

DEA Form 225
(Dec. 1982) - 225 OMB No. 1117-0012

RETAIN COPY 3. Mail Orig. and 1 copy with FEE to:
UNITED STATES DEPARTMENT OF JUSTICE
DRUG ENFORCEMENT ADMINISTRATION
P.O. Box 26083
CENTRAL STATION
WASHINGTON, D.C. 20005
For INFORMATION, Call: (202) 254-8255
See "Privacy Act" Information on Reverse

NEW
APPLICATION FOR REGISTRATION
UNDER
CONTROLLED SUBSTANCES ACT OF 1970

READ AND COMPLETE ALL APPLICABLE ITEMS
PRINT or TYPE All Entries

No registration may be issued unless a completed application form has been received (1801.21 CFR 21)

REGISTRATION CLASSIFICATION: Submit Check or Money Order Payable to: DRUG ENFORCEMENT ADMINISTRATION in Amount specified for Activity checked below.

1. BUSINESS ACTIVITY: (Check one only; see NOTES on Instruction Sheet before checking)
 RESEARCHER - Fee \$ 5.00
 ANALYTICAL LAB - Fee \$ 5.00
 MANUFACTURER - Fee \$ 50.00
 IMPORTER - Fee \$ 25.00
 DISTRIBUTOR - Fee \$ 25.00
 EXPORTER - Fee \$ 25.00

2. DRUG SCHEDULES (Check all applicable schedules in which you intend to handle controlled substances.) Complete Item 9 if applicable.
 SCHEDULE I
 SCHEDULE II
 SCHEDULE III
 SCHEDULE IV
 SCHEDULE V
 NONNARCOTIC
 NARCOTIC

3. (E) Check this block if applicant is exempt from payment of Registration Fee. If checked, applicant's superior must complete Item 5.
4. (Y) Check here if you require Order Forms.
5. Supply any other DEA Registration Numbers for any class of business activity at the address shown on this application.

COMMANDER
ATTN: Provost Marshal
CITY STATE ZIP CODE
Fort Bridge Arizona 78901

THIS BLOCK FOR DEA USE ONLY

Signature of Certifying Official: Alan T. Hughes Date: 20 Apr 1984
Name of Institution or Agency: U.S. ARMY
Print or Type Name & Title: Major General, Commander, Fort Bridge, AZ

9. DRUG CODE NUMBERS must coincide with the schedules requested. Listed below are the Drug Code requirements for each business activity:

Analytical Lab - Not required to list drug codes	Manufacturer - Schedule I, II, III, IIII In addition to codes furnished, bulk manufacturer (synthesizer/extractor) applicants MUST Circle Below those "Basic Classes" of controlled substances in Schedule I and II which they propose to "Manufacture in Bulk"
Distributor - Schedule I	Importer - Schedule I and II on Instruction Sheet)
Researcher - Schedule I and II on Instruction Sheet)	

IF ADDITIONAL SPACE IS REQUIRED, USE A SEPARATE SHEET AND RETURN WITH APPLICATION.

WARNING: Section 843(A) (4), Title 21, United States Code, states that any person who knowingly or intentionally furnishes false or fraudulent information in this application is subject to imprisonment for not more than four years, a fine of not more than \$30,000.00, or both.

MAIL the Original and 1 copy to the above address. Retain 3rd copy for your records.

MANUFACTURERS ONLY (Item 1E, Business Activity):
MA NA SCHEDULES
I II III IIII V

Check Schedules & Category applicable in the boxes to the right. (Definitions on Reverse)

A Bulk, Synthesizer-Extractor
B Dosage Form
C Repacker - Resealer
D Non-Human Consumption

7. ALL APPLICANTS MUST ANSWER THE FOLLOWING:
(a) Are you currently authorized to manufacture, distribute, dispense, prescribe, conduct research, in instructional activities, or chemical analysis with, or otherwise handle the controlled substances in the schedules for which you are applying, under the laws of the State or jurisdiction in which you are operating or propose to operate? YES NO
Current State License Number for the State in which you are applying for Registration: NA
(b) Has the applicant been convicted of a felony in connection with controlled substances under state or federal law? YES NO
(c) Has the applicant ever surrendered a previous CSA registration or had a CSA registration revoked, suspended, or denied? YES NO
(d) If the applicant is a corporation, association, or partnership, has any officer, partner, or stockholder been convicted of a felony in connection with controlled substances under state or federal law? YES NO
(e) If the applicant is a corporation, association, or partnership, has an officer, partner, or stockholder surrendered a previous CSA registration or had a CSA registration revoked, suspended, or denied? YES NO

IF ANSWER TO QUESTIONS (b), (c), (d), or (e) is YES, include a statement using the space provided on the REVERSE of this part.

Print or Type Name, Title, Signature
John E. Law 202: 555-1234
Applicant's Business Profile Number (Optional)
19 Apr 84
Date
Lieutenant Colonel, MPC, Provost Marshal
Title of the person signing on behalf of the applicant. E.g., President, Dean, Procurement Officer, etc.....

DRUG ENFORCEMENT ADMINISTRATION

Figure 4-3. Sample completed DEA Form 225—Schedule I

DEA Form 225 (Dec. 1982) OMB No. 1117-0012

NEW APPLICATION FOR REGISTRATION UNDER CONTROLLED SUBSTANCES ACT OF 1970

READ AND COMPLETE ALL APPLICABLE ITEMS
PRINT or TYPE All Entries

No registration may be issued unless a completed application form has been received (1201.81 CFR 31)

REGISTRATION CLASSIFICATION: Submit Check or Money Order Payable to: **DRUG ENFORCEMENT ADMINISTRATION** in Amount specified for Activity checked below.

1. BUSINESS ACTIVITY: (Check one only; see NOTES on Instruction Sheet before checking)
 RESEARCHER - Fee \$ 5.00 ANALYTICAL LAB - Fee \$ 5.00
 MANUFACTURER - Fee \$ 50.00 DISTRIBUTOR - Fee \$ 25.00
 IMPORTER - Fee \$ 25.00 EXPORTER - Fee \$ 25.00

2. DRUG SCHEDULES (Check all applicable schedules in which you intend to handle controlled substances.) Complete Item 9 if applicable.
 SCHEDULE I SCHEDULE II SCHEDULE III SCHEDULE IV SCHEDULE V
 NONNARCOTIC NARCOTIC

3. (E) Check this block if applicant is exempt from payment of Registration Fee: if checked, applicant's superior must complete Item 8.

4. (V) Check here if you require Order Forms.

5. Supply any other DEA Registration Numbers for any class of business activity at the address shown on this application.

6. MANUFACTURERS ONLY (Item 15, Business Activity):

NA	NA	NA	NA	NA	NA	NA	NA	NA	NA
Check Schedules & Category applicable in the boxes to the right. (Definitions on Reverse)	A	B	C	D	E	F	G	H	I
	Bulk, Synthesizer-Extractor	Dosage Form	Repacker - Relabeler	Non-Human Consumption					

7. ALL APPLICANTS MUST ANSWER THE FOLLOWING:

(a) Are you currently authorized to manufacture, distribute, dispense, prescribe, conduct research, in instructional activities, or chemical analysis with, or other ways handle the controlled substances in the schedules for which you are applying, under the laws of the State or jurisdiction in which you are operating or propose to operate? YES NO

(b) Current State License Number for the State in which you are applying for Registration: NA

(c) Has the applicant been convicted of a felony in connection with controlled substances under state or federal law? YES NO

(d) Has the applicant ever surrendered a previous CSA registration or had a CSA registration revoked, suspended, or denied? YES NO

(e) If the applicant is a corporation, partnership, or other entity, has any officer, partner, or stockholder been convicted of a felony in connection with controlled substances under state or federal law? YES NO

(f) If the applicant is a corporation, partnership, or other entity, has an officer, partner, or stockholder surrendered a previous CSA registration or had a CSA registration revoked, suspended, or denied? YES NO

IF ANSWER TO QUESTIONS (b), (c), (d), or (e) IS YES, include a statement using the space provided on the REVERSE of this part.

John E. Low
 Print or Type Name Here - Sign Here 202: 555-1234
 Applicant's Business Phone Number (Optional)

Signature of applicant or authorized individual: *John E. Low* 20 Apr 84
 Date

LIEUTENANT COLONEL MPC PROVOST MARSHAL
 Title (If the applicant is a corporation, institution, or other entity, enter the TITLE of the person signing on behalf of the applicant, e.g., President, Dean, Procurement Officer, etc.)

RETAIN COPY 3. Mail Orig. and 1 copy with FEE to:
 UNITED STATES DEPARTMENT OF JUSTICE
 DRUG ENFORCEMENT ADMINISTRATION
 P.O. Box 20083
 CENTRAL STATION
 WASHINGTON, D.C. 20005
 For INFORMATION, Call: (202) 254-8255
 See "Privacy Act" Information on Reverse

CITY STATE ZIP CODE
 Fort Bridge Arizona 78901

ATTN: Provost Marshal

Commander

THIS BLOCK FOR DEA USE ONLY

8. CERTIFICATION FOR FEE EXEMPTION (Complete only if Item 3 is checked)
 The undersigned hereby certifies that the applicant herein is an officer or employee of a Federal, State or local agency who, in the course of such employment, is authorized to obtain, dispense, or prescribe controlled substances or is authorized to conduct research, instructional activity or chemical analysis with controlled substances, and is exempt from the payment of this registration fee.

Alan T. Uniform 20 Apr 84
 Signature of Certifying Official Date

Alan T. Uniform
 Major General, Commander, Fort Bridge, AZ
 Print or Type Name & Title

US ARMY
 Name of Institution or Agency

9. DRUG CODE NUMBERS must coincide with the schedules requested. Listed below are the Drug Code requirements for each business activity:

Analytical Lab - Not required to list drug codes
 Distributor - Schedule I
 Exporter - Schedule I and II
 Importer - Schedule I and II
 Manufacturer - Schedules I and II (See Note B on Instruction Sheet)

Manufacturer - Schedule I, II, III, IV, V
 In addition to codes furnished, bulk manufacturer (synthesizer/extractor) applicants MUST Circle Below those "Basic Classes" of controlled substances in Schedule I and II which they propose to "Manufacture in Suit":

9041									

IF ADDITIONAL SPACE IS REQUIRED, USE A SEPARATE SHEET AND RETURN WITH APPLICATION.

WARNING: Section 843(A) (4), Title 21, United States Code, states that any person who knowingly or intentionally furnishes false or fraudulent information in this application is subject to imprisonment for not more than four years, a fine of not more than \$30,000.00, or both.

MAIL the Original and 1 copy to the above address. Retain 3rd copy for your records.

Figure 4-4. Sample completed DEA Form 225—Schedule II

CONTROLLED SUBSTANCE ACCOUNTABILITY RECORD										
For use of this form, see AR 190-12; proponent agency is ODCSOPS										
ORGANIZATION/INSTALLATION			DEA REGISTRATION NO.			DEA FORM 322a NO.				
Provost Marshal, Fort Bridge, AZ			A 1111-0000			Z44560000				
The controlled substances received from this order were repackaged (or weight checked) as indicated below.										
ENTRY NO.	TRAINING AID/CONTAINER NO.	WEIGHT AND CODE OF SUBSTANCE	WEIGHT AND TYPE OF CONTAINER	TOTAL WEIGHT OF TRAINING AID	WEIGHT CHECKED/PACKAGED BY	DATE AND INITIALS	REMARKS			
1	1-1-1	10g MJ	Nylon 8g Hose	18g	ILT James Behr	12 JUL 83				
2	1-1-2	17g MJ	Cloth 5g Bag	22g	ILT James Behr	12 JUL 83	Don't BT 19 JUL 83, 2g md lost. Rest (15g) repackaged into 1-1-5 (Entry # 11)			
3	1-1-3	5g (seeds) MJ	Plastic 3g Bag	8g	ILT James Behr	12 JUL 83	Unusable seeds sent Registered med (234.547) to DEA 18 JUL 83 DEA Form 41 completed.			
4	1-1-4	168g MJ	Plastic 18g Bag	186g	ILT James Behr	12 JUL 83				
5	1-2-1	6g HE	Red 4g Balloon	10g	ILT James Behr	12 JUL 83	Destroyed 16 JUL 83. DEA witnesses. DEA Form 41 completed			
6	1-2-2	8g HE	Metal 80g Box	88g	ILT James Behr	12 JUL 83				
7	1-2-3	6g HE	Plastic 3g Bag	9g	ILT James Behr	12 JUL 83				
8	1-3-1	4g CO	Plastic 3g Bag	7g	ILT James Behr	12 JUL 83				
9	1-3-2	6g CO	Plastic 18g Bag	24g	ILT James Behr	12 JUL 83	Bag stained 14 AUG 83. Lost 2g Rest (5.2g) to DEA by Reg MAN (284.778) 22 AUG 83			
10	1-3-3	10g CO	Metal 80g Box	90g	ILT James Behr	12 JUL 83				
11	1-1-5	15g MJ	Cloth 5g Bag	20g	ILT James Behr	19 JUL 83	See Entry # 2			

Code Key: Marijuana--MJ; Hashish--HH; Heroin--HE; Cocaine--CO

DA FORM 4608-R, Oct 84

Figure 4-5. Sample completed DA Form 4608—R

CONTAINER/TRAINING AID NO.			ORGANIZATION/INSTALLATION			CONTROLLED SUBSTANCE TRAINING AID UTILIZATION RECORD For use of this form, see AR 190-12; proponent agency is ODCSOPS			PAGE NO.	NO. OF PAGES
1-1-2			PROVOST MARSHAL, FORT BRIDGE, AZ			A 1111-0000			1	1
DEA REGISTRATION NO.			REMARKS			DEA FORM 222b NO.			244560000	
DATE AND TIME OUT	WEIGHT OUT	RECEIVED BY (Signature grade and title)	DATE AND TIME IN	WEIGHT IN	RECEIVED BY (Signature grade and title)					
14 JUL 83 0700	22g	Paul Sade TRAIN SACK 243 TAK OFF	14 JUL 83 1230	22g	John Jones TRAIN SACK 243 CLASSICAL	TRAINING AREA #2				
19 JUL 83 0730	22g	Paul Sade TRAIN SACK 243 TAK OFF	19 JUL 83 1000	20g	John Jones TRAIN SACK 243 CLASSICAL	BUDG 234 - Dry distilled container				
						2g MS lost. Rest				
						(15g) repackaged into # 1-1-5.				
/										

DA FORM 4607-R, Oct 84

Figure 4-6. Sample completed DA Form 4607—R

CONTAINER/TRAINING AID NO.		1-3-2		ORGANIZATION/INSTALLATION		PROVOST MARSHAL, Fort Bridge, AZ		CONTROLLED SUBSTANCE TRAINING AID UTILIZATION RECORD		For use of this form, see AR 190-12; proponent agency is ODCSOPS		PAGE NO.	NO. OF PAGES
										DEA REGISTRATION NO.		1	1
										A 1111-0000		DEA FORM 222c NO. 744560000	
DATE AND TIME OUT	WEIGHT OUT	RECEIVED BY (Signature, grade and title)	DATE AND TIME IN	WEIGHT IN	RECEIVED BY (Signature, grade and title)	REMARKS							
13 JUL 83 0930	24 g	Kelly Hull SFC TAG NCO	13 JUL 83 1200	24 g	Peta Jones SSG CUSTODIAN	PMO Parking Lot							
16 JUL 83 1000	24 g	Bud Suck 2LT TAGS OFF	16 JUL 83 1000	24 g	Peta Jones SSG CUSTODIAN	Bldg # 236							
21 JUL 83 0900	24 g	Kelly Hull SFC TAG NCO	21 JUL 83 1530	24 g	Peta Jones SSG CUSTODIAN	Main Parking Lot							
24 JUL 83 0830	24 g	Bud Suck 2LT TAGS OFF	24 JUL 83 1730	24 g	Robert Kane 1SG Aft Custodian	Airfield							
5 AUG 83 1130	24 g	Bud Suck 2LT TAGS OFF	5 AUG 83 1630	24 g	Robert Kane 1SG Aft Custodian	PMO Parking Lot							
14 AUG 83 1015	24 g	Kelly Hull SFC TAG NCO	14 AUG 83 1415	23.2 g	Peta Jones SSG CUSTODIAN	Bldg 234 Dog cleaned; .8g lost Investigation initiated							
Report of findings of investigation mailed to Commander USAMBA on 16 AUG 83													
Remaining cocaine in 1-3-2 sent to DEA by Registered Mail (#234,778) on 22 AUG 83. DEA form 41 completed.													

DA FORM 4607-R, Oct 84

Figure 4-7. Sample completed DA Form 4607—R

CONTROLLED SUBSTANCE ACCOUNTABILITY RECORD
 For use of this form, see AR 190-12; proponent agency is ODCSOPS

ORGANIZATION/INSTALLATION

Provost Marshal, Fort Bridge, AZ

DEA REGISTRATION NO.

A 1111-0000

DEA FORM 222a NO.

Z44560000

The controlled substances received from this order were repackaged (or weight checked) as indicated below.

ENTRY NO.	TRAINING AID/COM. TAINER NO.	WEIGHT AND CODE OF SUBSTANCE	WEIGHT AND TYPE OF CONTAINER	TOTAL WEIGHT OF TRAINING AID	WEIGHT CHECKED/PACKAGED BY	DATE AND INITIALS	REMARKS
1	1-2-3			9 GRAMS	MAS B. MERRY Co A 1/2 INF	14 AUG 83 BMM	
2	1-2-3			9 GRAMS	CPT JOHN SMITH Co B 3/4 MRSY	16 SEP 83 JST	
3	1-2-3			8.8 GRAMS	MAS B. MERRY Co A. 1/2 INF	15 OCT 83 BMM	

Code Key: Marijuana--MU; Hashish--HH; Heroin--HE; Cocaine--CO

DA FORM 4608-R, Oct 84

Figure 4-8. Sample completed DA Form 4608-R (weight check)

Chapter 5 Explosives Training Aids

5-1. General

The proficiency of EDDs is a critical skill that depends on continual reinforcement through training. To maintain satisfactory proficiency (95 percent or better detection rate), EDDs must be given a minimum of 4 hours of explosives detection training each week.

a. Within safety limits, training should be conducted in the same or a similar environment to that which the EDD team will be required to work. Some examples of good training environments are barracks just after all occupants have left for training, post exchanges, commissaries, and theaters just after closing. This includes any other facility that will provide real or nearly real conditions, and that will not present an unreasonable safety hazard to personnel not involved in the training exercise. Detailed requirements to ensure the safety of personnel during training exercises are given later in this chapter.

b. In selecting facilities for training, consideration should be given to the structure of the building. Some buildings may be much more susceptible to high cost structural damage in case of an accidental explosion than others. Taking this factor into consideration may lead to selection of alternate facilities with relative little, if any, loss in training effectiveness or realism. For example, a commissary warehouse may be selected as a training site in place of the commissary. The same wide variety and concentration of odors will be present. Therefore, much of the effectiveness of performing the training in the commissary is maintained.

c. In selecting facilities to be used for EDD training, a plan should be developed in conjunction with local safety and engineer personnel. A listing of buildings or facilities to be used should be compiled. The selection process should take into consideration the personnel exposure or safety factors listed later in this chapter, the factors listed above, and the need to maintain EDD detection proficiency in varied surroundings (that is, in buildings with variation of distracting odors, floor surfaces, outside noises, and so forth). Once a plan is formed, the installation commander should be informed of, and approve, the list of buildings or facilities selected for use. The plan should include the projected frequency of training and safety precautions being taken. Included would be the following:

- (1) Prior notification of, and coordination with, building or facility managers.
- (2) Evacuation of area in which training is taking place.
- (3) Compliance with provisions of safety precautions prescribed in this chapter.

5-2. Explosives used for training

a. A variety of explosives training aids are needed to maintain proficiency. Many different explosive compounds are in use today and the explosives used in homemade bombs may range from common household materials to the most sophisticated military or commercial chemical compounds. Nearly all explosives, however, have certain identifiable elements that are found in at least one of the explosives used for training aids. Dogs trained to detect these explosives training aids can therefore detect most other explosives. The handler must develop an understanding of what odors the dog is able to detect to be sure that the EDD is consistently trained to detect the explosives substance rather than containers, wrappings, tapes, and other material which may be present. The following types of explosives are authorized for training of EDD teams:

- (1) Commercial dynamite.
 - (a)* Gelatin.
 - (b)* Ammonium nitrate.
- (2) Military dynamite.
- (3) Water gel (TOVEX).
- (4) TNT (trinitrotoluene).
- (5) Smokeless powder.
- (6) C-4 plastic explosive.
- (7) Detonating cord.
- (8) Potassium chlorate.
- (9) Sodium chlorate.

b. All of the explosives included in the list in *a*, above are contained in the explosive scent kit, and should be available to the EDD team for training. Each of these explosives should be used frequently enough to maintain the EDDs detection proficiency at 95 percent or better on each of the explosives. The general rule to follow is to use any type of explosive, varying the amount and type from day to day. Of the basic types of explosives to be used, C-4 plastic explosive has the strongest odor. This is followed by dynamite, smokeless powder, TOVEX, detonating cord, and TNT. The chlorates are a relatively new addition and their position in the odor spectrum has not been established.

5-3. Explosives characteristics

The effectiveness of the EDD team depends on the dog's ability to detect explosives substances. This ability can be greatly enhanced by the handler's knowledge of the characteristics of explosives, the source of the odor the EDD is trained to detect, and how explosives devices are constructed. The information provided here is intended to give only a general understanding of explosives. Handlers should use this information as a foundation for further study in other Army publications on explosives (field manuals and technical manuals) and related references.

a. Smokeless powder.

(1) Smokeless powder is the world standard propelling powder for small arms, cannons, and, in a slightly different form, some rockets. All low explosives currently used as propellants have a nitrocellulose base and are commonly referred to as smokeless powders. Various organic and inorganic substances are added to the nitrocellulose base during manufacture to give improved qualities for special purposes. Various commercial trade names or symbols may be used to identify the family of smokeless powders.

(2) Smokeless powders are produced by dissolving gun cotton (nitrocellulose) in a mixture of ether and alcohol to form a mass called colloid. The colloid has a consistency of melted glue and is squeezed into macaroni-shaped tubes that are subsequently cut in short lengths. The ether and alcohol used to dissolve the guncotton are evaporated, leaving a hard substance. The small cylindrical powder grains resulting from this process are generally used as rifle ammunition powders.

(3) Pistol powders, unlike rifle powders, do not generally have cylindrical grains. Instead, they are manufactured in the form of very fine, thin wafers, flakes, or balls. These shapes ensure the shorter burning time necessary for full combustion in weapons with short barrels. Shotgun powders are similar to pistol powders in that they burn more rapidly than rifle powders. Most shotgun powders are straight nitrocellulose in composition.

(4) Like black powder, smokeless powders vary widely in both form and color. The majority of rifle and pistol powders are black in color and are formed into rods, cylindrical strips, round flakes, or irregular grains. Shotgun powders may be translucent round or square flakes, orange to green in color, or may be black irregularly shaped granules. Smokeless powders of all types are sold in tin flasks, glass jars, plastic containers, and kegs of varying weights up to 25 pounds.

(5) Unconfined smokeless powder burns with little or no ash or smoke and, when confined, its rate of burning increases with temperature and pressure. For this reason it is frequently used in the construction of pipe bombs. It should be noted that smokeless powder manufactured for use in small arms ammunition is usually glazed with graphite to facilitate machine loading and prevent the accumulation of static electricity. Many of these powders are as sensitive to friction as black powder. Therefore, the precautions used in handling black powder should be observed for smokeless powder.

(6) The age of the smokeless powder can also affect the dog's detection ability. The ether base dissipates with age when the powder has been exposed to the open air. Therefore, training aids should be made using both old and new smokeless powder.

b. C-4 plastic explosive. Composition C-4 is a composite explosive containing 91 percent Research Department Explosive (RDX) and nine percent nonexplosive plasticizers. C-4 has a greater shattering effect than the earlier C-3. C-4 is white to light brown in color and does not stain the hands. C-4 is often used in letter bombs because it can be shaped easily to fit the letter. Even though only a small amount of C-4 is used, it has such a strong odor that detection should be easy for the dog when searching mail. C-4 is available as a block demolition charge in the M5A1 2 1/2-pound block or the M112 1 1/4-pound block. Additional information on this and other explosives can be found in FM 5-25.

c. Detonating cord.

(1) Detonating cord consists of a core of PETN or RDX in a textile sheath, waterproofing materials, and plastics. Detonating cord will detonate at a speed of approximately 21,000 feet (or four miles) per second. Various colorings and textiles patterns are used to identify different explosive strengths and types of detonating cord. Detonating cord resembles safety fuse, is approximately the same diameter, and is supplied in rolls or coils. Detonating cord is nearly always distinguishable by its white or pink powder core. Detonating cord is manufactured under brand names such as Primacord, Primex, Detacord, Detonating Fuse, Cordeau Detonant, or Cord Tex.

(2) Most of the common detonating cords contain 50 to 60 grains of PETN per foot. A white crystalline powder, PETN is an extremely powerful explosive. Although pure PETN is white, the addition of desensitizers may slightly change its color to light gray. Detonating cord which contains up to 400 grains of PETN as a core load is dyed pale green in color. There are other lower energy detonating cords designed for specific applications, especially for operations in developed areas where a reduced noise level is desired.

(3) Another special type of detonating cord is used in operations where the ability to withstand high temperature is required, such as oil well jet perforating. This type of detonating cord has a black nylon or synthetic rubber outer sheath and the explosive core is 70 to 80 grains of RDX per foot. The RDX core load is pink. RDX is used because it can be exposed to crude oil and well fluids at high pressure and temperature (up to 325 degrees Fahrenheit) for as long as 2 hours without deterioration or detonation.

(4) Detonating cord is used with high explosives in the same way as blasting caps. Detonating cord may be tied

around, threaded through, or knotted inside explosives to cause them to detonate. Detonating cord is also used when a simultaneous detonation of a number of explosive charges is planned, and when it is not practical to use electrical circuits for this purpose. A single line of detonating cord can be laid out from the firing point in a path that will pass near all of the explosive charges. From this main line shorter lengths of detonating cord are attached to the charges. A blasting cap is attached to one end of the main line of the detonating cord to initiate detonation of all the charges simultaneously.

d. TNT. TNT is the most common military explosive. Alone or as part of a composite explosive, TNT is used widely as a booster charge, bursting charge, and demolition charge. TNT is a standard explosive that serves as a basis for rating other explosives. The TNT most likely to be found will be in 1/4-, 1/2-, or 1-pound blocks. When TNT is removed from its cardboard container, it is light yellow brown in color. TNT gradually turns dark brown after several days exposure to sunlight. Some TNT also may be gray in color due to the addition of graphite during manufacture.

e. Water gels (TOVEX). Water gels, or blasting slurries, are a new commercial group of blasting agents. These consist of nitrocellulose mixtures, with or without TNT, in a gel-like substance. Powdered metals, such as aluminum may be added to increase their performance. Water gels can be poured into irregular or wet bore holes to fill all available space with explosive. Most water gels require an explosive booster or primer for detonation. Some water gels also are being manufactured that can be detonated by using a blasting cap. Water gels may be packaged in plastic bags, 1 1/2 to 8 inches in diameter, or may be delivered to the blasting site by special pump trucks.

f. Military dynamite.

(1) Military dynamite is a composite explosive which consists of 75 percent RDX, 15 percent TNT, five percent SAE 10 motor oil, and five percent flour. When removed from its wrapper, military dynamite is a buff colored granular substance which crumbles easily and is slightly oily to the touch. It does not cause the headaches which are a typical side-effect for personnel who handle commercial dynamites.

(2) Military dynamite is used as a substitute for commercial dynamites in military construction, quarry work, and demolitions. It is equivalent in strength to 60 percent straight dynamite. Since it contains no nitroglycerin, military dynamite is safer to handle, transport, and store than commercial dynamite. Military dynamite is relatively insensitive to heat, shock, friction, or bullet impact.

(3) Military dynamite is packaged in standard dynamite cartridges. The cartridge may be marked either M1, M2, or M3 depending on the cartridge size only. All military dynamite detonates at about 20,000 feet per second.

g. Commercial dynamites. Commercial dynamites include straight dynamites, ammonia dynamites, gelatin dynamites, and ammonia gelatin dynamites.

(1) The explosive base of straight dynamite is liquid nitroglycerin absorbed in a mixture of various carbon-rich materials, such as wood pulp or ground meal. Sodium nitrate is added primarily to supply oxygen for complete combustion of the carbon-rich materials and increase the strength of the explosion. When removed from its wrapper, straight dynamite will generally be light tan or reddish-brown in color. While the texture of straight dynamites may vary, they are usually loose, slightly moist, oily mixtures similar to a mixture of sawdust, clay, and oil. Straight dynamites are manufactured and graded in ranges from 15 to 60 percent.

(a) The nitroglycerin gives straight dynamite a heavy, pungent, sweet odor. Breathing straight dynamite fumes, even for short periods of time, will usually cause a very persistent and severe headache. Nitroglycerin liquid and vapors are quickly absorbed by the body and enter the bloodstream producing the headache. Although aspirin and other pain relievers have little effect on such headaches, some relief may be obtained by drinking strong black coffee or caffeine citrate. Personnel in constant contact with nitroglycerin usually develop some immunity from the headaches. This immunity, however, can be maintained only by almost daily contact.

(b) Straight dynamites are rarely used in general blasting work because they are highly sensitive to shock and friction, and they are highly flammable. When detonated, they produce toxic fumes which make them unsuitable for use underground or in confined spaces. Because of their nitroglycerin content, straight dynamites are the most hazardous of the dynamites to handle and store. Boxes or sticks of dynamite in storage must be periodically turned over to prevent the nitroglycerin from settling to the bottom and leaking out of the dynamite stick. Any dynamite that appears to be deteriorating or leaking an oily substance should be moved only by properly trained EOD personnel.

(c) A form of straight dynamite that is widely used in commercial blasting operations is called ditching dynamite. Ditching dynamite is manufactured in a 50 percent grade in sticks 1 1/4 inches by 8 inches and is used for blasting ditches. If soil conditions are right, ditching dynamite will detonate by propagation. This eliminates the need for individual priming of each charge with blasting caps or detonating cord. A principal characteristic of ditching dynamite is its relatively high detonation velocity of almost 17,000 feet per second. This rapid detonation produces a powerful shock wave and good earth shattering effect.

(2) In the manufacture of ammonia dynamites, ammonium nitrate replaces a portion of the nitroglycerin. This substitution produces a dynamite which costs less and which is less sensitive to shock and friction than straight dynamite. Ammonia dynamite has a lesser shattering effect and, therefore, is more suitable for quarry operations, stump or boulder blasting, and hard pan gravel or frozen earth blasting. Because of its ability to move or dislodge objects, ammonia dynamites are probably the most widely used explosives of the dynamite family. Ammonia dynamites are generally made in strengths from five to 70 percent with detonation velocities ranging from 3,600 to 13,000 feet per

second. When the wrapper is removed, ammonia dynamite will appear light tan to light brown in color and will have a pulpy, granular, slightly moist, oily texture. It has the same odor as straight dynamite because of its nitroglycerin content, and may also produce severe headaches after short periods of contact.

(3) Gelatin dynamites have a base of water resistant "gel" made by dissolving or colliding nitrocotton with nitroglycerin.

(a) The gel varies from a thick viscous liquid to a tough rubbery substance. Gelatin dynamite is neither hygroscopic nor desensitized by water, and therefore avoids two of the disadvantages of ammonia dynamite. Since it is insoluble in water and tends to waterproof and bind other ingredients with which it is mixed, gelatin dynamite is well suited for all types of wet blasting work. Because of its density, it is also used extensively for blasting very hard, tough rock or ore.

(b) Gelatin dynamites are manufactured in strengths from 20 to 100 percent. Gelatin dynamite will also detonate at two velocities. Unconfined, the lower rated strengths will detonate at about 7,000 feet per second. Confined, gelatin dynamites will detonate at approximately 13,000 feet per second. Detonation velocities up to 23,600 feet per second are available. Semi-gelatin dynamites have characteristics that fall between those of ammonia dynamites and ammonia-gelating dynamites.

(4) Ammonia-gelatin dynamites have most of the characteristics and qualities of gelatin dynamites. A portion of their strength is provided by using less costly ammonium nitrate. Ammonia-gelatin dynamites are manufactured in strengths of 25 to 90 percent, with detonating velocities ranging from about 7,000 to 23,000 feet per second.

h. Dynamite detonation. All dynamites may be detonated using either electric or nonelectric blasting caps or detonating cord. Since blasting caps are extremely sensitive, a hole is made in the dynamite stick before the cap is inserted. A blasting cap crimper tool has a pointed handle, and is usually used to prepare dynamite for insertion of the blasting cap.

i. Ammonium nitrate.

(1) Ammonium nitrate is one of the least sensitive and most readily available main charge high explosives. It ranges in color from white to buff-brown, depending on its purity, and has a salty taste. Colored dyes may be added to aid identification. Ammonium nitrate is usually found in the form of small compressed pellets called prills. It is used extensively as a blasting agent or as a cratering charge, and as an ingredient in the manufacture of some dynamites. Ammonium nitrate is commonly used as a fertilizer.

(2) Even a high explosive grade of ammonium nitrate generally needs a booster for detonation. For cratering charges, TNT is used as the booster. RDX or pentolite boosters or primers are often used for commercial applications. The detonation velocity of ammonium nitrate ranges from 3,300 to 8,200 feet per second. Ammonium nitrate absorbs moisture easily (hygroscopic) and will lose power and sensitivity as its moisture content increases. As a result, ammonium nitrate is usually packaged in some type of waterproof container.

j. Sodium chlorate and potassium chlorate. Both sodium chlorate and potassium chlorate are substances which are frequently being used in improvised explosive devices (homemade bombs). These chlorates are available as a pharmaceutical or from a chemical supplier. The strength and odor is affected by exposure to air or moisture, so most explosive devices made using chlorates will be packaged in waterproof materials. For training, the chlorates should never be mixed with each other or with other substances. Chlorates used for training will need to be replaced frequently (about every three months) because of their exceptionally rapid loss of potency (odor and strength).

5-4. Procurement of explosives training aids

a. Procurement. Procurement of explosives training aids is the responsibility of the installation PM, security officer, or the MP unit commander. The source of training aids and the procedures for obtaining explosives training aids will be established before the request for authorization of EDDs is submitted. Arrangements need to be made with the installation activity having installation responsibility for procurement and storage of explosives, and with the nearest EOD unit. Army installations or activities with authorized and assigned EDD teams are authorized to procure and issue the explosive scent kit which contains the items listed in paragraph 5-2 for the purpose of providing explosives training aids for proficiency training of MP EDD teams.

b. Inventories.

(1) Inventories will be made:

(a) Monthly.

(b) When a new explosives training aid custodian is appointed.

(c) When an explosives training aid is not accounted for at the conclusion of the daily training session, lost from storage or when there has been a breach in security of the storage room or storage container.

(2) Monthly inventories will be conducted by a disinterested person (anyone not assigned to or with direct responsibility for the installation MWD program) in grade E-7 or above, who is appointed by the PM or security officer, or by the installation or activity commander. Inventories which are required because of losses or breaches of security will also be conducted by a disinterested person.

(3) Change of primary custodian inventories will be joint inventories between the old and new custodian.

(4) An inventory will account completely for all quantities of explosives training aids maintained as training aids and will be a complete audit of the accountability records pertaining to those substances. Only those records that are

active and those that have not been audited previously need to be audited. The person conducting the inventory will positively account for all quantities and types of explosives training aids by verifying the previously established audit trail.

(5) The person conducting the inventory will prepare a report for the PM or security officer or other appointing authority. A copy of the report will be maintained with the explosives training aids folders in a secure files storage area. Inventory reports will be maintained for at least two years from the date of the report.

(6) Inventory reports will include the following information:

(a) Date of inventory and the inclusive dates of all controlled substances accountability records included in the inventory.

(b) Name, rank, and unit of the person conducting the inventory. Include a copy of any written appointing document for disinterested persons or the appointing document for a new custodian.

(c) Quantity of each type of explosive received.

(d) Quantities of each explosive disposed of or destroyed.

(e) Quantities of each explosive on hand or in use.

(f) State whether the inventory and audit of records successfully accounted for all explosive aids. If all explosives could not be accounted for, state what action was taken to resolve the discrepancies and any recommendations to improve accountability procedures.

(g) Evaluate the custodian's compliance with security, accountability, and control procedures.

5-5. Cutting training aids

Explosives training aids issued for individual team training will not exceed the following quantities:

a. *Commercial dynamite or military dynamite—one stick per training aid.* Use a normal manufactured configuration. Do not cut dynamite. Size and weight may vary between types and brands of dynamite.

b. *TNT—no more than 16 ounces per training aid.* Use a normal manufactured configuration. Do not cut TNT.

c. *Smokeless powder—no more than 16 ounces per aid.* Smokeless powder may be removed from the container and repackaged into other containers as necessary. Preparation should be carried out in a suitable remote location.

d. *C-4 plastic explosive—no more than 20 ounces per aid.* Use a normal manufactured configuration. If cutting or dividing is necessary, only qualified munitions or EOD personnel should do the cutting or dividing.

e. *Detonating cord—no more than 10 feet per training aid.* Detonating cord may be cut with a knife.

f. *Potassium chlorate and sodium chlorate—30 grams (or one ounce) per aid.* The portion of the chlorate not being used should be left in a tightly closed storage container. The training aid used will be stored separately to avoid contaminating the remaining chlorates.

5-6. Storing explosives

Explosives must be stored in vapor proof containers in facilities that meet the requirements of AR 385-64. The security requirements for explosives are contained in AR 190-11, AR 710-2 and AR 740-26 prescribe inventory, accountability, and issue procedures.

5-7. Issue and turn-in procedures

a. Explosives and explosives training aids will only be issued to those individuals who have received the explosives safety training required in AR 190-12. All personnel who are authorized to receive and handle explosives training aids will be designated in writing by the PM, security officer, or unit commander.

b. DA Form 581 (Request for Issue and Turn-in of Ammunition) will be used for requesting, receipting for, and turning in explosives used for training. Local procedures will be established to ensure that all quantities of explosives issued for training are all returned to secure storage. Thefts and/or losses will be investigated as required by AR 190-11.

c. Only the amount of explosives needed for that day's training will be issued.

5-8. Vehicle transportation requirements

Explosives are transported only in Government vehicles meeting the criteria of TM 9-1300-206 and/or AR 55-355, as appropriate. Vehicles must be certified as safe for explosives transportation by explosives safety personnel.

a. Before each use, the driver of the vehicle being used to transport explosives will inspect the vehicle to be sure it is in good mechanical condition and that all safety equipment is in working order. This inspection includes the following:

(1) The vehicle must have two approved Class B/C (CO2 or dry chemical) fire extinguishers that are fully charged. One extinguisher is mounted on the outside of the vehicle on the driver's side and the other on the inside of the cab.

(2) All electrical wiring must be in good condition and all connections properly attached.

(3) Fuel tanks and fuel lines will be secure and free of leaks.

(4) Brakes, tires, steering and other equipment should be in proper working order. Tire inflation pressure should be checked and adjusted if necessary.

(5) Exhaust system will be free of oil, grease, and fuel.

(6) "Explosives A" placards will be mounted on the sides, front, and rear of the vehicle (and/or trailer).

b. Each type of explosive should be transported in a separate closed container. Containers should not be metal or other material that would fragment. Paper, cardboard, or light wood should be used. Each container must be marked to show the type of explosive in it.

c. Explosives are only transported in the cargo compartment of the vehicle. Personnel and MWDs will not ride in or on the cargo area with explosives.

d. Each explosives container should be immobilized so that it cannot shift during transit. Sandbags should be placed between containers and around the sides of the cargo compartment.

e. Wheel chocks should be used when the vehicle has stopped to prevent the vehicle from rolling from its stationary position.

5-9. Explosives safety

The consistent practice and observance of explosives safety requirements is as important to the credibility of the EDD team as the maintenance of the team's proficiency. There can be no tolerance of unsafe practices because carelessness invites disaster. Before any individual is allowed to handle explosives, he or she must be fully knowledgeable of explosives safety requirements and should be able to demonstrate that knowledge in both training and real situations.

5-10. Explosives safety training

Each PM, security officer, or MP unit commander will ensure that personnel who will be involved in EDD training have been thoroughly trained in the safe storage, transportation, and handling of each type of explosive to be used as training aids before they are allowed to conduct or take part in this training. This training should be conducted by or with the direct assistance of EOD or explosives safety personnel. The initial explosives safety training will occur before the individual participates in any training where explosives are present. Training will be repeated at least annually thereafter. A written record of all explosives safety training conducted, including a list of personnel (by name) who have been trained, will be maintained for at least two years. Explosives safety training will include at least the following subjects as they relate to the types and quantities of explosives to be used in training.

a. Storage requirements.

b. Security requirements.

c. Vehicle transportation requirements.

d. Explosives handling and personnel precautions.

e. Extinguishing agent for explosives fires.

f. Fire department assistance.

g. Explosive ordnance disposal assistance.

h. Emergency actions.

i. Physical characteristics of each type of explosive used.

j. Functional characteristics of each type of explosive used.

k. Sensitivity to shock, heat, electricity, moisture, and corrosive agents of each type of explosive used.

l. Hazards related to each type of explosive used.

m. Procedures for using, placing and recovering explosives used in training.

5-11. Explosives safety requirements

a. Proficiency training is best done in the same environment in which actual searches would most likely be done. For example, public buildings such as post exchanges, commissaries, schools, banks, and warehouses provide a suitable training environment, as well as aircraft, vehicles, motor pools, petroleum storage areas, open areas around water towers, electrical power stations, and so forth. Training in these areas must be coordinated in advance with the users so as not to disrupt normal operations. Whenever possible, training should be done after normal operating hours but as close to the end of the operational period as possible to simulate building or area evacuation.

b. Training must not be done during an electrical storm or when an electrical storm is approaching. Always contact the local weather station or military weather detachment before training is conducted to be sure weather conditions will permit a safe training exercise. If an electrical storm comes up during training, all training activity will be stopped and explosives will be returned to the storage area. If time does not allow for safe return to the storage area, all explosives will be placed in an open unoccupied area at least 300 feet from occupied buildings, personnel, or equipment. The person in charge of the explosives will maintain surveillance over them during this period from at least 100 feet.

c. Before training starts, the fire department will be notified of the training location and the amount and type of explosives to be used. Proper fire symbols will be posted around the training area so that they are clearly visible from approach roads used by fire fighters. A class B/C type fire extinguisher will be readily available in the training area.

- d.* All persons handling commercial dynamite will wear rubber or plastic gloves to prevent the absorption of nitroglycerin into the skin. Dogs will not be allowed to pick up any explosive training aids in their mouths.
- e.* Smoking is prohibited within 100 feet of explosives used in training or within 100 feet of any actual search location.
- f.* All persons not actively involved in training exercises will be evacuated to a distance of at least 100 feet from the training area. Only the minimum number of personnel required to conduct the training will be authorized in the training area.
- g.* The total quantity of explosives used in any training event must not be more than 5 pounds of explosives. This quantity may be a mix of any of the types of authorized explosives.
- h.* Blasting caps, squibs, explosive detonators, or any type of initiating explosive or device may not be used for training when other explosives are being used. When training EDDs with initiating devices, only those devices (no explosives) may be present in the training area.
- i.* Explosives training aids will not be placed near any heat or spark producing source such as electrical wiring and outlets, radiators, heaters, heat vents, car engines, ash trays, or any other source of potential ignition.
- j.* Explosives training aids should not be placed inside metal containers that would fragment in case of accidental initiation.
- k.* When multiple training aids are used, they must be placed at least 50 feet apart to prevent propagation in case of accidental detonation.
- l.* Leave training aids in place only for the minimum time necessary for required odor dispersion, search, and recovery. Collect all training aids immediately after the training period.
- m.* Training aids must be kept under constant surveillance. **DO NOT LEAVE EXPLOSIVES UNATTENDED!**

Chapter 6

Health, Care, and Feeding

Section I

Veterinary Medical Care

6-1. Veterinary services

- a.* The Army provides veterinary service for all MWDs as authorized by DOD Directive 6015.5, AR 40-1, AR 40-3, and AR 40-905.
- b.* At most locations, veterinary medical care is provided by the assigned installation veterinarian. When there is no assigned installation veterinarian, a veterinarian from a nearby military installation will be assigned responsibility for providing veterinary health services.
- c.* The PM, security officer, or the MP unit commander who has the MWD assigned or the military veterinarian will be responsible for approving all emergency civilian veterinary care when a military veterinarian is not available. If routine military veterinary care is not available, the attending Army veterinarian will establish procedures to ensure that adequate care is provided.

6-2. Veterinary responsibilities

- a.* The Surgeon General, U.S. Army, through the Army Veterinary Corps, provides professional veterinary medical support for the entire MWD program. This responsibility includes:
 - (1) Medical and surgical care at training facilities, bases, and installations.
 - (2) Sanitary inspection of kennel facilities.
 - (3) Professional review of plans for new construction and modification of kennels, support buildings, and sites.
 - (4) Prescribing an adequate feeding program.
 - (5) Instructing dog handlers and supervisors in all matters related to the health of MWDs.
 - (6) Conducting research to improve the MWD program.
- b.* The veterinarian provides treatment for the diseased or injured MWD at the kennel site or at the installation veterinary medical treatment facility. The veterinarian is responsible for equipping this facility and for providing medical and surgical supplies.
- c.* Physical examinations of dogs being offered to the military by sale or donation are given free of charge to make sure only healthy dogs are procured. MWDs also receive a physical examination before and after shipment.
 - (1) An examination is given just before shipment from one installation to another. A health certificate is issued for the state or country into which the dog is being shipped for PCS or TDY greater than 30 days. When the TDY period exceeds 30 days, the MWD will be accompanied by a health certificate prepared and signed by a veterinarian no more

than 10 days prior to embarkation. If TDY location is in a different Army veterinarian area of operation, the gaining veterinarian will be notified prior to departure from the home station.

(2) An arrival examination is given as soon as possible, but not more than 30 days after arrival of a dog at a new location.

(3) The dogs are examined to detect injury or disease and support the safe shipment and continued good health of the dog.

d. Dogs are routinely immunized against contagious diseases. Immunizations begin at the procurement or training facility and are continued regularly throughout the dog's service life. The zoonosis control program refers to prevention and control of diseases and conditions common to man and other animals. Rabies is an example. The veterinarian will train MP personnel about control and preventive measures to minimize the possibility of getting diseases from dogs.

e. At least quarterly, the veterinarian inspects the kennel facility and area to make sure that proper sanitary standards are being maintained. The veterinarian ensures that insect and rodent control efforts are adequate, and that the general health of the dogs judged from appearance, grooming, and feeding is being properly maintained by the handler. The quarterly inspection also includes the following elements:

(1) Examine the kennel facilities for safety hazards and distractions that may interfere with the rest and relaxation of the dogs.

(2) Review the adequacy of the kennel structure (particularly for environmental conditions), and the adequacy of feeding and watering schedules. Make recommendations to help prevent disease and injury.

f. The veterinarian instructs handlers about dog health, care, feeding, and first aid. This instruction helps the handler to have a better understanding of the dog's health needs and improves the handler's ability to care for the dog.

g. The veterinarian is responsible for the MWD medical record and related information about examinations, immunizations, and treatment.

h. The veterinarian prescribes an appropriate feeding program based on the dog's health, the climate, and working conditions.

i. The veterinary officer is involved in the review of all plans for new kennel construction or kennel modifications. This is to ensure potential health and safety hazards can be corrected before construction begins.

j. Veterinarians may conduct medical research in support of the MWD program to improve the health, welfare, and effectiveness of the dogs.

Section II

Diseases and Parasites

6-3. Disease prevention

The nature of the work being performed by MWD teams and the importance of this work to the Army mission makes the dog's continuing good health a matter of special attention. The veterinarian provides the professional expertise for treatment, prevention, and control of disease; however, only the handler is in daily contact with the dog. Handlers must be knowledgeable about the physical indicators of failing health in a dog, so prompt action can be taken to help the dog recover. Handlers must be familiar with their dog's normal body functions, such as temperature, appetite, and stool, and must know their dog's normal attitude. Changes must be reported to the veterinarian. Although handlers may not be able to recognize a specific disease, they should be able to recognize the symptoms of illness and be able to describe the symptoms to the veterinarian.

6-4. Contagious diseases

a. Infectious diseases are caused by microscopic or macroscopic organisms. Contagious diseases that can be transmitted between humans and other animals are zoonotic diseases. Four of the more important contagious diseases of dogs are:

(1) *Canine distemper*. This is a widespread, highly contagious, and often fatal viral disease that occurs primarily in young dogs. The airborne virus is easily transmitted from dog to dog but does not affect humans.

(2) *Infectious canine hepatitis*. This is a widespread viral disease found most commonly in young dogs but also in older dogs that are not immunized. The mortality rate is not as high as from distemper, but recovery takes a long time. The virus is spread through the urine, mainly by the use of feeding and drinking utensils contaminated by urine. It does not infect humans.

(3) *Leptospirosis*. This disease, commonly known as "lepto," is caused by a spirochete and is fairly common.

(a) Animals other than dogs can be infected by the disease, and it can be transmitted to humans. It is spread through the urine, usually of dogs and rats. Therefore, in addition to immunization, it is essential that dogs do not consume contaminated food and water.

(b) Rodent control is important in preventing the spread of this disease since rats are the most common carriers.

(c) Where leptospirosis is known or suspected to exist, dogs should not be allowed to enter or drink surface water that may be contaminated by urine or dead animals.

(d) The possibility of human infection reinforces the need for personal cleanliness. Handlers must protect themselves from urine contamination when caring for sick dogs.

(e) Although vaccination will usually prevent the dog from exhibiting clinical signs of disease, vaccination of the dog against leptospirosis does not prevent the dog from shedding the infectious organisms in its urine. Therefore, it is possible to transmit the infectious organism to a human or unvaccinated dog that comes in contact with the infected dog's urine. Food sanitation practices are important in the control of this disease. Runs and kennels should be cleaned and sanitized daily.

(4) *Parvovirus*.

(a) This is an infectious and contagious viral organism which is shed in the stool, vomitus, and urine.

(b) There is a vaccine available which protects the dog against the disease.

(c) The clinical signs of the disease are vomiting (usually green in color) and bloody diarrhea. The dog is usually off food and water for a day prior to onset of the clinical signs.

(d) After onset of the vomiting and bloody diarrhea, the MWD could die within hours if veterinary medical treatment is not obtained. The animal should be taken to a veterinarian immediately.

(5) Dogs infected with any of the diseases discussed in this paragraph usually exhibit one or more of the symptoms listed below. When a dog shows such symptoms, or other changes in normal body functions, the veterinarian must be notified.

(a) Elevated temperature.

(b) Loss of appetite.

(c) Depression.

(d) Loss of weight.

(e) Loss of energy.

(f) Diarrhea.

(g) Vomiting.

(h) Coughing.

(i) Thick discharge from the eyes and nose.

(j) Muscle stiffness.

(k) Convulsions.

b. Rabies, like leptospirosis, is a zoonotic disease. The rabies virus in the saliva of infected animals is readily transmitted to humans through the bite wounds or contact of saliva with broken skin.

(1) Rabies affects all warm blooded animals. Most frequently infected are skunks, raccoons, bats, foxes, dogs, cattle, and cats.

(2) There are two stages of rabies seen in dogs:

(a) In dumb rabies, the most common stage of rabies seen in dogs, the animal will usually have the following signs: excessive drooling from the mouth, sit at one place with blank expression and howl, and unable to move jaw and, therefore, cannot swallow food or water.

(b) In furious rabies, the dog will have a sudden change in temperament or attitude, become very excitable and bite at all objects placed in front of him, appears to walk aimlessly about (loss of eyesight), and not able to swallow food or water. Rabid wild animals often lose their natural fear and will attack rather than retreat.

(3) Handlers must prevent contact between their dogs and wild or stray animals. Contact resulting in bites or scratches must be reported to the veterinarian. Extreme cautions must be used during the capture to prevent bites to personnel.

(4) If a handler is bitten by an animal, medical treatment should be given as soon as possible. In areas where rabies is endemic, handlers and other personnel with an increased occupational risk of exposure to rabies should receive prophylactic rabies immunization from their local medical facility.

c. Other contagious diseases for which vaccines do not exist, such as upper respiratory infections, pneumonia, and gastroenteritis, can infect dogs. Infected dogs may show symptoms including high temperature, loss of appetite, loss of energy, vomiting, diarrhea, and coughing. Any of these symptoms must be reported to the veterinarian.

6-5. Parasite infestations

Parasites can spread disease organisms to other dogs or humans. Dogs may serve as host to a large number of parasites and control of infestation is of prime importance to the dog's health.

6-6. External parasites

Parasites that live in or on the skin of the dog cause damage by sucking blood or actually eating the tissue. The dog responds by biting and scratching the irritated areas, which may lead to severe skin infections and may drastically affect the dog's working ability. The following paragraphs discuss the most common external parasites.

a. Ticks are common in many parts of the world. They suck blood from the dog and, when present in large numbers, may cause a serious loss of blood. Ticks can be observed standing still on the dog's body with their heads

deep in the skin. Ticks spread diseases by sucking blood or tissue fluid from a diseased animal and then moving to another animal.

(1) Care is required in removing ticks since they may carry zoonotic disease. Inflammation of the dog's skin may result if all of the tick is not removed. The correct procedure for removal is to place the fingers or tweezers around the body of the tick and as close to the dog's skin as possible. The tick's head is then slowly withdrawn. Ticks deep in the ear canals must be removed only by veterinary personnel due to the danger of ear injury. Ticks should be disposed of by flushing down the nearest drain or immersion in alcohol. Personnel should always wash their hands after handling ticks.

(2) Ticks may be found in cracks in the floors and sides of the kennel, and in the grass and bushes of the training and working areas. They may live away from the dog's body as long as a year without having to return to the dog for a blood meal. To control ticks, the kennels, training areas, and working areas should be treated with insecticides. The veterinarian should assist with the selection and approval of the insecticides to be used for this purpose, because many insecticides are harmful to dogs.

b. Fleas torment the dog, irritate the skin, and spread disease. They crawl or hop very rapidly through the dog's coat. Like ticks, they are difficult to control since they do not spend all of their time on the body but live in cracks in the kennel and in grass around the kennels. Fleas also may transmit tapeworms from dog to dog. Control requires repeated individual treatment and kennel sanitation.

c. Lice (biting and sucking types) commonly affect dogs. Biting lice live off the dog's tissues; sucking lice suck blood. Both produce great irritation. Biting lice crawl over the skin and through the hair. Sucking lice are usually immobile, and stand perpendicular to the skin. The eggs of lice, called nits, are small, white or gray, crescent shaped objects fastened to the hairs. Lice, unlike fleas and ticks, can live only a short time when they are not on the dog's body. Control, therefore, requires treatment only of affected animals.

d. Mites of several types irritate the ear canal or produce mange.

(1) The ear mite lives in the ear canals and causes a severe irritation. The mites are small but are visible to the naked eye as tiny, white crawling specks. Affected dogs scratch at the ears and cock their heads to one side or shake them. Examination of the affected dog's ear canals usually reveals a large amount of dark colored waxy discharge.

(2) Mange mites live in the animal's skin. The sarcoptic mange mite can be transmitted to humans. Mange mites are too small to be seen by the naked eye, but a skin scraping of the infested area will reveal them under a microscope.

(3) Mites also spend their entire life on the dog. Control, therefore, depends primarily on treatment of the affected animals.

6-7. Internal parasites

Like external parasites, internal parasites (living in the body) irritate the tissues, rob the body of blood or essential elements of the diet, or interfere with specific body functions. Only part of the life cycle of internal parasites is spent in the dog's body. A knowledge of this life cycle, or the stages of development from egg to adult, is important in the control of parasites. The life cycles of several of the most commonly found internal parasites are discussed below.

a. Hookworms, one of the most harmful parasites, live in the dog's intestines. They are small and threadlike, 1/2 to 3/4s of an inch long. They suck blood and cause blood loss by tearing the intestinal wall.

(1) The adult worm lives in the dog's intestine, where eggs are produced by the female and passed in the dog's stools. Larvae develop from these eggs, and can infect the same or another dog. The larvae penetrate the dog's skin or are swallowed as the dog licks the ground or himself. The larvae pass directly into the lungs. Those reaching the lungs are coughed up and swallowed, reaching the intestine. Once in the intestine, they develop into adulthood hookworms, and the cycle begins again.

(2) Dogs with hookworms may have a variety of symptoms, depending on the severity of the infection. Membranes of the mouth and eyes may be pale, stools may be loose and contain blood, or the animal may lose weight. The veterinarian diagnoses the disease by microscopic examination of the animal's stools.

(3) Control of hookworms is done primarily by feeding rations with a chemical to prevent the worms from completing their life cycle. Other control measures include treating infected animals and keeping the area free of stools.

b. Roundworms also live in the intestine. They vary from two to eight inches in length.

(1) The life cycle of roundworms is similar to that of hookworms except the eggs do not develop into larvae until they have been swallowed by a dog. Adult roundworms rob the infected animal of essential nutrients in the diet and larvae produce an irritation as they travel through the lungs.

(2) Symptoms may include vomiting, diarrhea, loss of weight, and coughing. The diagnosis is made by finding the eggs in the stools. Occasionally, adult worms may be vomited or passed in a stool, in which case they may be seen by the handler.

(3) Control measures include treating the animal and good sanitation in the kennel area.

c. Whipworms are smaller than roundworms but larger than hookworms.

(1) The life cycle is very similar to that of the roundworm; however, the larvae do not travel to the lungs before becoming adults in the intestine of the infected animal.

(2) Symptoms include diarrhea, loss of weight, and paleness of membranes of the mouth and eyes. Diagnosis is made by finding the microscopic eggs in the stool. Control measures are the same as for roundworms.

d. Tapeworms are long, flat, and ribbonlike. They have many segments and a head. The tapeworm attaches its head to the wall of the intestine. Several kinds of tapeworms may infect the dog's intestine.

(1) The life cycle of the tapeworm is rather complex. In one type of tapeworm, after the eggs have been passed in the dog's stool, they are eaten by the larvae of the dog flea. The larva develops when the adult flea is eaten by a dog. The larva enters the dog's intestine and develops into an adult tapeworm.

(2) The symptoms are usually not too noticeable, but may include diarrhea and loss of appetite or weight.

(3) Some types of tapeworms pass through the bodies of rabbits, mice, or squirrels during their life cycle. Dogs may become infected by eating a rabbit or other animal containing the tapeworm larvae.

(4) Often the eggs of the tapeworm cannot be detected by the veterinarian during stool examinations. However, segments passed by the infected dog may be seen in the stool or among the hairs in the dog's anal region. They are small, white objects about 1/4 of an inch long, and may be seen moving.

(5) Control measures require treatment of the infected animal, good sanitation in the kennel area, control of fleas, and not allowing the dog to eat animals that are likely sources of infection.

e. Heartworms are found in the heart and lungs rather than the intestine. These parasites are threadlike in appearance, are 6 to 11 inches long, and interfere with the dog's heart action and circulation.

(1) The adult worms in the heart produce larvae called microfilaria. They circulate in the animal's bloodstream where they may be picked up by mosquitoes, the insect responsible for the spread of the parasite.

(2) The larvae continue their development in the mosquito and then are injected into the dog's tissues when the mosquito feeds. The microfilaria travel to the dog's heart and develop into adults.

(3) Symptoms include coughing, loss of weight, difficult breathing, and a quick loss of energy. The disease is diagnosed by the veterinarian during a blood test. Medication is given to kill the adult worms and microfilaria.

(4) Heartworms in dogs are controlled by a chemical added to the food ration to prevent the worms from completing their life cycle. Other control measures are treatment of infected dogs by a veterinarian to prevent them from serving as sources of infection, and controlling mosquitoes in the area.

6-8. Noninfectious diseases of dogs

Many diseases affecting dogs are not caused by viruses, bacteria, or other infectious agents. Some noninfectious diseases are overheating, arthritis, bloating, chronic kidney disease, and allergy. The symptoms of a noninfectious disease may resemble those of an infectious disease or may be hardly noticeable. Gradual loss of weight, excessive water consumption, excessive urination, and obscure lameness are symptoms that may be hard to detect. A handler alerted by any abnormal changes in a dog should report the observation to the veterinarian.

Section III

Medication and First Aid

6-9. Special medication

At times, a veterinarian prescribes special medication for a sick or injured dog, to be given separately or mixed with food. The handler must know how to administer these medications in both pill and liquid form.

a. When any foreign substance is placed directly into a dog's mouth, his first reflex is to spit it out. The handler must learn how to administer medication properly so that the dog is forced to swallow.

(1) To administer capsules or tablets, the handler places the fingers of the left hand over the muzzle and inserts the left thumb under the lip and between the dog's upper and lower teeth right behind the canine tooth, pressing the left thumb against the roof of the mouth to open the dog's mouth.

(2) Place the capsule or tablet into the dog's throat at the extreme rear of the tongue to prevent the dog from spitting it out. The handler then quickly removes the hand, closes the dog's mouth, and gently massages the dog's throat. The entire procedure must be quick and smooth to allay the dog's apprehension and resentment.

b. Liquid medication is best given with the help of another person.

(1) With the left hand, the handler holds the upper and lower jaws together; with the right hand, the assistant pulls the dog's lips away from the teeth at one corner of the mouth. The dog's nose is then pointed slightly upward, forming a natural funnel by the lip, and the assistant pours the liquid into this funnel.

(2) In giving liquid medicine, elevate the head only slightly above the horizontal. If the head is raised higher, the dog has difficulty in swallowing. Give the dog adequate time for swallowing to prevent the liquid from getting into the trachea, nose, or lungs. Use extreme caution in giving oily liquids.

(3) If any signs of distress appear, such as coughing or struggling, allow the dog to lower his head and rest before proceeding. Do not give oral medications or any liquids if the dog is unconscious or cannot swallow.

6-10. First aid

a. Normally, the handler's early recognition of symptoms of illness or injury allows sufficient time to get assistance

from a veterinarian. However, situations may arise when medical help is not immediately available. The seriousness of the incident may require that the handler take emergency actions to protect the life or health of the dog. The first aid instructions which follow are the most common used to save life, prevent further injury, and to reduce suffering from pain. In all emergency situations, notify the veterinarian as soon as possible so that the dog can receive professional medical attention.

b. First aid kits should always be available in the kennel area and at training sites. The handler should also carry a first aid kit as part of his or her equipment for the dog on all operational missions. The contents of first aid kits will be determined by the veterinarian. Any time items are used from the first aid kit, used items should be replaced with new items immediately.

6–11. Physical restraint

When a dog has been injured, the first consideration is to calm and immobilize the animal. Pain and distress, however, may cause the dog to respond to the handler in an unpredictable manner. The dog may not respond to verbal command and may attempt to bite the handler and anyone helping the handler. Whether to apply a muzzle or not depends on the nature of the emergency. If the dog is unconscious, shows any difficulty in breathing, or has suspected head injuries, a muzzle should not be used. Otherwise, a muzzle should be used for safety.

a. There are several types of muzzles, but the leather basket muzzle is the best and most comfortable. It allows free breathing, and causes the least alarm and apprehension. The dog can still inflict a wound while wearing this type of muzzle, so caution is required.

b. An improvised muzzle can be made using the dog's leash and is called a leash muzzle.

(1) To apply this muzzle, tighten the choke chain on the dog's neck by pulling the leash tightly with the right hand. Place the left hand, palm up, under the choke chain on the neck. Grasp the leash tightly as it passes through the palm of the left hand, wrap the leash once around the dog's neck, and bring it up and across the left side of the dog's head. Finally, wrap the leash twice around the muzzle and grab it tightly with the left hand.

(2) This muzzle may be used when the leather muzzle is not available or when it would not provide adequate safety. Do not use the leash muzzle when the dog is overheated, is having difficulty breathing, or if there is an indication the dog may vomit. Do not leave it on for long periods in hot weather.

6–12. Fractures

Broken bones and fractures are potentially the most serious injuries because the dog will probably continue trying to move around. Movement must be prevented. Continued movement will only make the injury more painful and serious.

a. A handler should suspect broken or fractured bones if the dog has been hit by a vehicle, was injured while jumping or climbing, has been hit by a large projectile, and so forth. The symptoms of a break or fracture may be swelling, deformity, limited ability or inability to use a body part, irregular bone contour, or a bone sticking out of a wound.

b. If a fracture or break has occurred, immediately restrain the dog to prevent any possible injury to people and to minimize the possibility of further injury to the dog. Send for veterinary help and keep the dog quiet and warm to prevent shock. Unless absolutely necessary, do not move the dog until the veterinarian arrives. If a bone is sticking out of a wound and there is bleeding, attempt to reduce the bleeding using sterile gauze bandages. If bleeding is severe and gentle pressure will not stop the bleeding, apply firm pressure over the artery that supplies blood to the broken limb. Apply pressure carefully to avoid causing greater injury.

c. If the dog must be moved before veterinary assistance can be obtained, the area of the fracture should be immobilized before attempting to move the dog. This may be accomplished by using a solid object such as a board or stick as a splint.

(1) Gently bring the limb into as natural a position as possible, without moving the area around the fracture.

(2) Lay the support or splint along the limb in the most comfortable and natural position. Do not apply the splint directly over the open fracture.

(3) Secure the splint to the limb, firmly but gently, by tying a strip of cloth as far above the injury as possible. The strip of cloth must be applied above the joint immediately above the injury. Tie another strip of cloth as far below the injury as possible. The second strip must be applied below the joint immediately below the injury. If the break cannot be splinted so that the joint above and below the injury are immobile, follow the instructions in d below. Be careful not to restrict blood circulation by tying the splint too tightly.

(4) If practical, bandage the whole limb lightly, wrapping the entire splint and limb.

(5) Move the dog no further than absolutely necessary and avoid leaving the limb and splint without support even if the only support is a cushion or supporting hand.

d. If the fracture cannot be splinted, transport the dog on a firm litter made from board strips or a sheet of plywood large enough to permit the dog to lie comfortably.

6–13. Wounds

a. Bleeding must be quickly controlled, particularly wounds in the foot or leg which bleed freely. Bleeding may be

controlled by applying pressure directly on the wound. Use a sterile bandage or a clean handkerchief, or pinch the edges of the wound with your fingers. As soon as possible, apply a pressure bandage.

b. If bleeding cannot be controlled by using pressure, use of a tourniquet may be necessary until a pressure bandage can be applied. Tourniquets may be improvised from a leash, belt, necktie, bootlace, or a piece of gauze bandaging material. A tourniquet is dangerous because, if not applied properly, it could stop all blood supply to the area below it and cause serious damage. Apply a tourniquet three or four inches above the wound (between the wound and the heart) with just enough pressure to control bleeding. When a pressure bandage can be applied, remove the tourniquet.

6-14. Burns

Serious burns seldom occur with animals. Most burns occur when an animal comes into contact with hot water, hot grease, hot tar, or other hot, scalding liquids. Dogs may also get electrical burns by chewing electrical wires. If a dog is trapped in a burning building, it may suffer from smoke inhalation in addition to surface burns. Minor burns may be treated by applying cold water soaks or ice packs to the burn for approximately 20 minutes. The cold helps to reduce the pain. The hair around the burn should be clipped away and the burn should be washed gently with a surgical soap. Blot dry with sterile or clean soft gauze or cloth and then apply a topical antibiotic ointment. Protect the burned area from rubbing by applying a loose fitting gauze dressing.

6-15. Shock

a. Frequently an animal will go into shock after injuries to internal organs, excessive bleeding, or trauma. Shock can be recognized by the following symptoms:

- (1) A glassy look to the eyes.
- (2) Rapid or weak pulse, or rapid shallow breathing.
- (3) Body temperature begins to drop, and the lips and feet may feel cold.
- (4) Paleness of the membranes of the mouth and eyes.

(5) Slow capillary refill time. To determine capillary refill time, press firmly against the dog's gums until they turn white. Release the pressure and count the number of seconds until the gums return to their normal color. If it is more than two to three seconds, the dog may be going into shock. Failure to return to the red-pink color at all indicates that the dog may be in serious trouble and needs immediate assistance.

b. If a handler suspects that a dog has internal injuries or is going into shock, request help from a veterinarian immediately. Keep the dog warm and quiet, and lower the dog's head to prevent possible brain damage. If it is necessary to move the dog, use a litter.

6-16. Artificial respiration

There are many conditions that may cause respiratory collapse (stop breathing). When this happens, do not panic. Follow the procedures listed below.

- a.* Open the dog's mouth and check for any obstructions. Extend the dog's tongue and examine its pharynx.
- b.* Clear the dog's mouth of any obstructions, blood and mucus, close the dog's mouth, and hold it gently closed.
- c.* Inhale, then cover the dog's nose and mouth with your mouth.
- d.* Exhale gently, do not blow hard. Carefully force air into the dog's lungs and watch for the dog's chest to expand.

Repeat every five to six seconds or at a rate of 10 to 12 breaths per minute.

6-17. Snake bites

The bite of a poisonous snake can cause serious illness and death if not treated immediately. If a dog is bitten by a poisonous snake, keep the dog quiet and calm and request veterinary assistance or move it as quickly as possible to a treatment facility. Panic or exertion causes snake venom to move more rapidly through the bloodstream. If possible, kill the snake so it can be shown to the veterinarian. The handler should be careful not to be bitten or come into contact with the snake venom. Many bites occur on the face or neck of the dog. When this happens, remove the choke chain and loosen or remove the collar and muzzle. Swelling occurs rapidly after a snake bite, and this equipment may restrict breathing. Position the dog's head extended from its body to allow the dog to get maximum airflow. An ice pack applied to the bite area helps to slow the flow of blood and helps to keep the venom from spreading. A **TOURNIQUET SHOULD NOT BE APPLIED!**

6-18. Foreign objects in the mouth

A dog may get a stick or other foreign object in its mouth or throat. The dog may cough, gag, have difficulty swallowing, paw at the mouth, and drool saliva. Rabies may cause similar symptoms, so the handler must be careful. If the dog is having difficulty breathing, cautiously and gently open the dog's mouth. Look for any abnormal object in the throat, under the tongue, between the teeth, in the gums, or stuck to the roof of the mouth. Gently try to dislodge the object by moving it from side to side. If no object can be found or the handler is unable to remove the object, request veterinary assistance.

6-19. Poisonous substances

There are many toxic agents (chemicals) a dog may come in contact with and/or ingest. These include insecticides, herbicides, rodenticides, antifreeze, and so forth. The symptoms or signs of poisoning vary. Unless the handler is certain the dog has eaten a poison, do not treat for poison. Occasionally, dogs have accidentally swallowed narcotics or explosives training aids. If the handler knows the dog has eaten a poison, narcotic, or explosive, take the following actions:

- a.* Request veterinary assistance immediately.
- b.* Determine the type and quantity of poison, chemical, narcotic, or explosive that has been swallowed. If any part of the substance or container is available, keep it for the veterinarian to examine.
- c.* The kennelmaster should obtain a list of common poisons and initial first aid procedures for these poisons from the Army veterinarian. Handlers can then refer to the list at those times that a dog may be poisoned and the veterinarian is not immediately available. If such a list is not available and the Army veterinarian is not available, immediate contact with a civilian veterinarian should be made. Causing an animal to vomit is not recommended in all types of poisoning as it may cause more harm to the animal. Where vomiting is appropriate, the animal may be induced to vomit by placing one to two tablespoons of salt on the back of its tongue.
- d.* Keep the dog quiet and warm until the veterinarian arrives.

6-20. Overheating

a. Overheating results when a dog is unable to eliminate body heat rapidly enough. This condition requires immediate action by the handler to save the dog's life. During hot, humid weather, a dog may easily become overheated during training, during operations, or while being transported. A body temperature of 105 degrees Fahrenheit or more, poor response to commands, weakness, unsteady movement, vomiting, difficult or labored breathing, convulsions, and collapse are all symptoms of overheating.

b. When the symptoms of overheating occur, carry the dog to the nearest shade and try to quickly lower the body temperature by running and sponging cold water over the dog's head, body, and legs. If a body of water is available, put the whole dog into the water, keeping the dog's head above water.

c. If it is possible to take the dog's temperature, more specific measures can be taken. If the dog's temperature is less than 107 degrees Fahrenheit and the dog is having no difficulty standing, placing the dog into an air-conditioned kennel or building and soaking the dog with tap water should be sufficient. If the dog's temperature is higher than 107 degrees Fahrenheit and/or the dog is having difficulty standing and/or the dog's mucous membranes are turning blue, more drastic actions are necessary. These would include the following:

(1) Immerse the body in a tub of ice water. The dog should be maintained up on its chest (sternal position) while in the tub. The depth of the water and ice mixture should be sufficient to completely cover the shoulders and back. The head must be held out of the water at ALL TIMES so that there will be no opportunity for water to be inhaled into the lungs. An ice pack can be placed on top of the head, and that portion of the neck not immersed can be massaged with ice water. Immersion of the animal into extremely cold water may cause the animal to go into shock (refer to para 6-15) or to stop breathing (refer to para 6-16).

(2) If an ice water bath is not immediately available, the dog should be soaked with ice water or an alcohol and ice water mixture until such a bath can be made available.

(3) Monitor temperature continuously. Stop cooling when temperature falls below 103 degrees Fahrenheit.

(4) If the temperature falls below 100 degrees, begin warming by drying and wrapping the dog with sheets and blankets. Remove heat when temperature goes above 101 degrees Fahrenheit.

(5) Continue to monitor the dog's temperature every 10 minutes for one hour after the dog has reached a normal body temperature.

(6) Do not let the dog overdrink. He should not consume more than one cup of water until he is calm and his temperature returns to normal.

6-21. Causes of bloat

Bloat is an acute stomach enlargement that may be due to gas, food, or water. It may occur if the dog is fed immediately before or after hard exercise, or when the dog is returned to his kennel after work or exercise and allowed to drink too much water.

a. An enlargement may be seen just behind the ribs, primarily on the left side. The dog will be restless and show signs of pain in the abdominal region. It will attempt to vomit or have a bowel movement. Breathing will be difficult or labored due to pressure from the enlarged stomach.

b. Handlers should notify the veterinarian and stop all watering and feeding. Walking may enable the dog to relieve himself through bowel movements or passing gas. Most cases require extensive treatment by the veterinarian.

c. To prevent bloating, dogs should not be fed within a two hour period prior to or after hard work or vigorous exercise. Giving small amounts of water during training or working in hot weather will prevent excessive thirst. For the

first hour after working or training, only three inches of water in the bucket should be available. After this cooling-off period, more water may be given.

Section IV

Care of dogs

6-22. Required sanitation

a. Cleanliness is one of the most important factors for good health of the MWD. The kennelmaster must enforce sanitary measures in and around the kennel area. A good standard of sanitation is the result of the cooperation of the handlers, kennelmasters, supervisors, and the veterinarian.

b. The veterinarian and the PM, security officer, or MP unit commander set the standard of sanitation. This standard must be maintained by each of the handlers and the kennelmaster.

c. Sanitation is one of the chief measures of disease prevention and control. The importance of disease control in a kennel facility cannot be overemphasized. The existence of a disease in one dog that might be passed on to other dogs must be the concern of every handler.

d. A disease that spreads through the kennels may seriously impair the effectiveness of the unit if a large number of animals become ill and have to be removed from duty. Disease control and sanitation cannot be separated. There are many ways to keep a good level of sanitation.

(1) The kitchen or food preparation area must be kept as clean as possible. Dogs may get diseases from food prepared with dirty hands or dirty utensils. To prevent disease, clean and sanitize the food and water utensils daily. Clean utensils immediately after each food preparation period. If canned foods are being fed for a special diet, the can opener must be cleaned after each use. Store food in rat-proof areas so that neither the food nor cans are soiled by rat urine or stools. The use of disinfectant procedures in the food preparation area may be required, but use must be approved by a veterinarian.

(2) Kennels must be sanitary, in a good state of repair, and thoroughly cleaned every day. Kennels should be disinfected at least once every week using only those disinfecting products approved by the veterinarian. Kennels also should be disinfected whenever an animal is removed from a kennel so that the kennel will be ready to be occupied by another animal.

(3) Stools are a common source of infection and must be removed from the runs as often as necessary. Before washing down concrete runs, remove the stools with a shovel to prevent them from splashing into adjacent runs, on the walls of the kennel, or on the dog. The method of disposing of stools depends on local conditions and the type of sewage system present. If stools must be carried from the area in cans, the cans must be cleaned and disinfected after each use.

(4) The entire kennel area must be free of refuse and garbage that could attract rats and insects. Mosquito control measures must be used in ditches and swampy areas in the vicinity of the kennels. Disinfectants and disinfectant procedures must be used only with the approval of the veterinarian.

(5) One of the causes of bacterial skin infections and bacterial ear infections in MWDs is the high humidity in the kennels. For this reason, it is important that handlers, when cleaning the kennels, remove the animals from the runs prior to washing the run. Then they should squeegee the run to dry it prior to putting the animal back in the run.

6-23. Grooming and inspection

Grooming and inspection are essential to the dog's health and well-being, and must be done daily. The physical closeness between the dog and the handler during daily grooming helps to develop the strong psychological bond between handler and dog that is necessary to function as a team.

a. German shepherd dogs have a double coat of hair; the undercoat of soft, wooly hair, and the outer coat of stiff, water-resistant hair. Daily grooming is essential to the proper care of the dog's coat and skin.

(1) In grooming, give the dog a brisk rubdown with the fingertips moving against the grain. This loosens dead skin, hair, or dirt, brings it to the surface, and massages the skin. Brushing against the grain follows. Next, brush the coat with the grain to return the hair to its natural position. Finally, hand rub the coat with the grain. This distributes the oil and gives the coat a glossy appearance. Occasional combing helps, but in winter, it should be limited to avoid tearing out the undercoat.

(2) An occasional bath may be necessary, but may remove the oils that keep the skin soft, prevent drying and cracking, and make the coat water repellent. The veterinary officer advises on the frequency of bathing, the type of soap, and how to protect the dog's eyes and ears. Rinsing after the bath removes soap left in the coat that may become sticky, collect dirt, or cause skin irritation. After drying with a towel, the dog may be gently exercised to complete the drying. Do not bathe a dog in cold or wet weather unless it can dry in a warm place.

b. Daily inspection is part of the grooming period. During inspections, check each part of the dog's anatomy for signs or symptoms of illness or injury. After a short acquaintance, the handler knows how the dog should look and act when healthy, what is normal for the dog, how the coat looks, frequency of bowel movements, and eating habits. In

daily inspection, this knowledge helps reveal anything abnormal, and if treatment begins early, the dog's recovery is more rapid.

c. Knowing the terms used to describe the dog's external anatomy enables the handler to read intelligently about the dog, to report symptoms of illness or injury accurately, and to understand the veterinarian's instructions. Figure 6-1 describes the parts of the dog's anatomy.

d. During inspection, the handler checks specific areas of his or her dog for symptoms of disease and injury.

(1) Illnesses are frequently accompanied by changes in the eyes and many illnesses affect only the eyes. Usually, a dog's eyes are bright and clear and the surrounding membranes have a healthy pink color. The small wedge-shaped membrane at the inner corner of the eyes is the nictitating membrane, or third eyelid. Usually, this covers a small part of the inner portion of the eye. The following are symptoms of illness or injury:

- (a) Red or yellow discoloration of the membranes and whites of the eyes.
- (b) Paleness of the membranes.
- (c) White or yellow discharges.
- (d) Cloudiness or other discolorations of the clear portion of the eyes (cornea).
- (e) Puffiness of the lids.
- (f) Lids partially or completely closed.
- (g) Nictitating membranes that cover more of the eyeball than usual.

(2) The black pad at the end of the dog's nose is usually shiny and moist. If it is persistently dry and dull, this may be a symptom of illness. Other symptoms are watery, yellowish, or red-tinged discharge, sneezing, snorting, and pawing at the nose.

(3) The erect external portion of the ear is called the earflap. The vertical ear canal extends down the earflap to the opening of the horizontal ear canal. The horizontal canal leads to the inner ear. A small amount of brownish wax in the vertical canal is normal.

(a) A reddish discoloration, swelling, or large amount of discharge in the ear canal should be reported. Also, report a foul odor coming from the canals, shaking of the head, holding the earflap down, holding the head to one side, twitching the ear, scratching or pawing at the ear, and evidence of pain when the ear is touched.

(b) Dirt and wax can be removed from the inner part of the earflap, but have the ears checked by the veterinarian even when they appear only to need cleaning. Never probe into the ear canal.

(4) In dog's mouth, gums, and inner lips are a healthy pink. Teeth are firm and white. Symptoms of illness include paleness of gums, sores, persistent drooling, bloody saliva, gagging or pawing at the mouth, and a foul breath. Loose and broken teeth, tartar accumulations on the teeth, and objects lodged between the teeth are conditions to report.

(5) A well fed and groomed dog usually has a glossy coat and skin that is soft and pliable. The coat changes in appearance with the climate and season.

(a) The undercoat is thicker in cold weather, and shedding is noticeable in hot weather.

(b) Indications of skin trouble are reddening, scabbing, moist discharges, scratching, abnormal shedding, loss of hair in spots, dryness, and loss of pliability.

(6) The dog's feet are inspected for foreign objects, cuts and bruises, and abrasion of the pads. Nails should not touch the ground when the dog stands. Long nails interfere with the dog's work. Report this and any broken or split nails. The dewclaws are not worn down by contact with the ground and require cutting. Lameness is a common sign of foot or leg problems.

(7) Check the dog's legs for wounds, swellings, and sores. If the elbow callous becomes inflamed, report it to the veterinarian.

(8) In a male dog, the penis is located in a fold of skin known as the prepuce or sheath, where a small amount of greenish-yellow discharge is normal. If this discharge is present in large amounts, report it to the veterinarian. A bleeding prepuce should be reported immediately. The scrotum, the pouch containing the testicles, should be checked for swelling, reddening, or scabbing. In the female dog, the external genital opening is the vulva. Usually, there is no discharge, but reddening of the vulva, or the skin in that area, and a discharge should be reported.

(9) The opening from the rectum is the anus. Report any swelling or reddening of the skin in the area of the anus. On either side of the rectum near the anus is a small sac that is a frequent source of trouble. When the anal sacs are full or infected, the dog may bite at the area or slide along in a sitting position. Report these symptoms to the veterinarian.

(10) The dog's attitude is one of the best indications of its general health. If the dog begins to show undue nervousness, loss of vitality and energy, an increased desire for sleep, tiredness, or inattentiveness while on post or in training, report this to the veterinarian. Also report changes in appetite, thirst, breathing, vomiting, a very soft or watery stool, or blood in the vomitus or stool. Watch the dog when it is urinating or having a bowel movement to detect blood in the urine or difficulty with the passage of urine or stools. If there is blood in the urine, notice whether it is in the first or last portion of the urine, or whether it is distributed throughout. Report increases or decreases in the frequency of urination and bowel movements.

(11) A dog's temperature is also an excellent indication of the animal's state of health. Usually, it is within the range of 101.0 to 102.0 degrees Fahrenheit.

(a) Variations frequently indicate an illness, although some variation in temperature may be normal; for example, following exercise or agitation. Consult the veterinarian when variations are found.

(b) The temperature is taken rectally, and the thermometer is held in the rectum from 2 to 3 minutes before reading. Lubricate the thermometer with soap or mineral oil to ease its insertion. As a safety precaution, muzzle the dog before taking its temperature.

(12) The kennel and run areas should always be checked for evidence of vomiting, abnormal stools, or bleeding.

6-24. Feeding dogs

MWDs require a diet that is significantly different from that of pet dogs. Their work demands much higher levels of energy and larger quantities of essential nutrients. Therefore, a special feed has been developed for these dogs. This food, Feed, High Caloric, Medicated, NSN 8710-00-403-4565, is commonly known as Maximum Stress Diet (MSD) and is procured through normal supply channels. MSD is a pellet size, dry dog food that can be fed directly from the container or mixed with water. It has measured amounts of medication against heartworm and hookworms. The amount fed depends on the weight of the dog.

a. MSD is packed in either metal or fiberboard cans sealed against moisture and contamination. Units should not keep more than a 30- to 60-day stock on hand at the kennel. Once a can is opened, it must be stored in a cool, dry location to protect against spoilage. If a can is opened and found to have an excessive amount of moisture or if it emits a foul odor, it is probably contaminated or spoiled and should not be fed to the dogs. Instead, return the can to supply for disposal.

b. Special diets may be procured and fed to individual dogs when the veterinarian determines that other than the standard diet is required. Normally, specially prescribed foods will be available from the local commissary.

c. Some dogs have been trained using a food reward schedule that also requires special food. Food reward is used only if a dog fails to respond to any other type of reward. Procure the special food through normal supply channels or by authorized local purchase.

d. Food other than MSD medicated should not be fed to MWDs except under the conditions described in b and c above.

e. The amount of MSD each dog should be fed depends on the dog's weight, amount of activity, and the climate. Local veterinarians determine the proper amounts to feed.

f. The veterinarian also prescribes the time of day each dog is to be fed. This depends on the dog's duty schedule and the schedule of other kennel activities.

g. After the prescribed feeding period, leftover food is disposed of within two hours and feeding pans are cleaned and put away. Never leave uneaten food in the kennel past the feeding period. The food spoils and, if eaten, makes dogs sick.

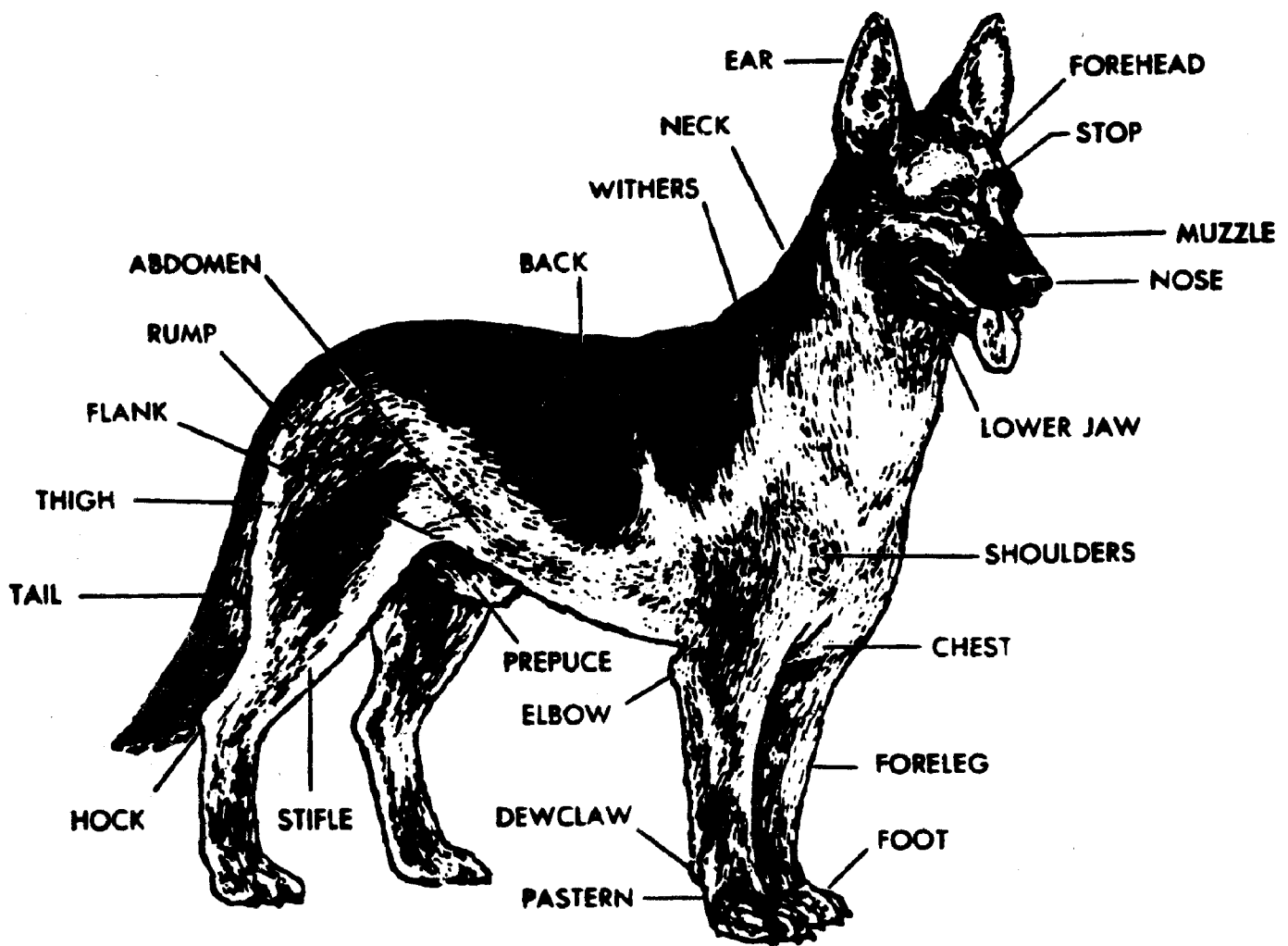

Figure 6-1. External anatomical parts

Chapter 7 Kennel Facilities

Section I Kennel and Support Facilities

7-1. Kennel requirements

A very important part of the decision process in determining whether to use or expand the use of MWDs by a unit or at an installation is the decision to construct kennel facilities. Standard kennel facilities are required for all MWDs, including the small breed detector dogs. Although there are instances where it has been necessary to quarter the small breed dog with the handler, this practice is only authorized until standard kennels can be constructed. The large breed dogs must always be quartered in either temporary or permanent kennels. Kennels provide the MWD with a standard, secure, sanitary facility that can be readily inspected. Kennels, for all MWDs which have been authorized or for which authorization is being sought, must be completed, inspected, and available for occupancy within 1 year after arrival of the dog(s) at the unit or installation. Failure to provide proper facilities for the dogs may result in reassignment of dog team assets and loss of the authorization for MWD teams. Kennel designs have been approved providing relatively low cost kennels for nearly any size MWD program. The designs in this chapter should be used as a guideline. Minor changes may be made to meet locally unique requirements.

7-2. Master planning

a. All proposed construction must be sited on the approved master plan for the installation. Development of the master plan is initiated by the installation commander working through the Installation Planning Board. When a kennel project has been validated by the Installation Planning Board as a new requirement and is not sited on the approved master plan, an individual site approval will be initiated. Each project will be consistent with the written goals and objectives, safety and environmental criteria, functional organization, land use, and infrastructure development of the installation. These procedures will be in accord with AR 210-20.

b. Kennels should not be located in built-up, busy areas of the installation. Although the dogs will tolerate some activity, activity which prevents them from getting adequate rest will affect their ability to perform effectively when required for duty. Also, when dogs are located in areas of moderate to high activity, the dogs will create a noise distraction to people working in the area. If the kennel must be located in a busy area, both visual and sound barriers will be necessary to minimize the distractions to the dogs.

c. It may be advantageous to build small kennel facilities near existing MP activities. Operations can be easier, handlers are more readily available, and the presence of the MP activity helps to provide at least some passive security for the kennels. However, the high level of activity normally associated with MP functions will necessitate the installation of visual and sound barriers around the kennel facility.

d. Kennels should be located as near as possible to existing primary water, power, and sewer lines to reduce site preparation and construction costs.

e. Kennels, support facilities, exercise and training areas should all be located on the same site to reduce travel time and transportation requirements for daily kennel activities.

f. To keep noise levels around kennel areas at a minimum, do not build kennels near aircraft runways, taxiways, weapons firing ranges, motor parks, installation commercial activities, or other areas where the time weighted overall average sound pressure level for any 24-hour period exceeds 75 decibels. Similarly, kennels should not be located in the vicinity of nuclear, biological, chemical (NBC) training sites, or other areas that may present an environmental or health hazard to the dogs or the handlers.

g. The selected kennel site must have natural ground slope or be graded so that accumulation of standing water during wet weather is prevented.

7-3. Kennel components

a. A permanent kennel facility will normally consist of four major components. The kennel is the area in which the dogs are quartered and secured. The kennel support building provides an area for the operational, logistical, and administrative support functions for the kennels, the dogs, and the handlers. The training area provides a safe and secure area for the obedience, confidence, and proficiency training of the dogs. The obedience course, which will normally be located within the training area, helps the dogs to maintain agility, stamina, and general physical fitness while reinforcing the obedience and confidence training. The exercise area provides a safe, secure area for individual dogs to be exercised when the dog's handler is not available. A separate exercise area also prevents interference with handlers and dogs who need to use the training area.

b. The kennel support facilities should consist of the minimum necessary space to adequately support the operation of the kennel, and the care, feeding, and training of the assigned MWDs. Kennel support buildings normally will include the following elements:

- (1) Food preparation room with counter, cabinets, sinks, refrigerator, stove, food cart, and storage racks.
- (2) Food storage room with sufficient shelving to store a 30-day supply of food for the dogs.
- (3) One office for the kennelmaster. Additional office space may be necessary depending on the size of the kennel facility and the number and types of MWD teams assigned. In very large kennels, separate office spaces may be provided for handlers of narcotic detector dogs, patrol dogs, and EDDs. This arrangement would give the kennelmaster and each of the functional teams with the same skills an area to maintain references and discuss operational matters.
- (4) Latrine with sink, toilet, and shower.
- (5) One large multipurpose room. The size of the room should be adequate for assembly of all the handler personnel authorized for the kennel. This room may be used as:
 - (a) An emergency examination and treatment area.
 - (b) A mission preparation room (ready room, briefing room, assembly area, and so forth).
 - (c) An administrative area where the kennelmaster or unit commander can conduct meetings, briefings, training classes, inspections, or other functions.
- (6) Isolation kennels are required only for kennels housing more than 20 dogs, or where a veterinarian is not located within a reasonable traveling distance (25 miles). Adequate space should be provided in the multipurpose room for a temporary prefabricated isolation kennel, if that becomes necessary, or the veterinarian may choose to hospitalize sick dogs in commercial veterinary facilities. Remote kennel sites should have one or more isolation kennels built adjacent to the multipurpose room. This would provide space for quarantine of sick animals and a recovery cage after routine dental prophylaxis or X-ray. Isolation kennels should all be indoor kennels. Two isolation kennels for every 20 dogs is recommended at isolated sites where veterinary services hospitalization capability is not readily available.

- (7) A tack room with shelves and racks for storage of the MWD equipment.
- (8) A mechanical equipment room for the furnace, water heater, and so forth.
- (9) Other closets and storage rooms, as necessary, for storage of handler equipment, tools, repair materials, equipment for building and exterior maintenance, and so forth.

7-4. Standardization

The purpose of this section is to prescribe standard criteria for US Army dog kennels in temperate and frigid climate locations and overseas locations. DOD 4270.1-M and this pamphlet are the primary sources of criteria for all kennel designs and construction projects, regardless of type of funds used.

a. Development of any kennel design will be directed towards achieving goals of austerity, simplicity, and economy of construction, consistent with minimum acceptable health and animal welfare standards. High cost materials, such as quarry tile, ceramic tile, and stainless steel, should not be used if less expensive materials will serve the same purpose. Concrete sealer, epoxy glaze, and plastic laminates are examples of less expensive materials.

b. To the maximum practical extent, passive energy conservation measures will be incorporated in the design of any kennel facility. One method of improving the flow of natural ventilation is to orient the kennels so that the length of the kennel building is on an east-west axis and the kennel building faces north or south. Adequate ventilation is necessary for proper health and sanitation. Therefore, kennel facilities should not be located where other buildings or vegetation will block the natural air flow. If natural ventilation does not prevent the humidity from building up in the kennels, fans or other methods must be used to increase the exchange of air in the buildings so that humidity may be reduced.

c. All kennels will be built to be able to accommodate large breed dogs.

d. The structural design of the kennel building will be modular to facilitate expansion of the kennel in pairs of kennel runs. Accordingly, the structural design should conform to TM 5-809-1 through -6 and -8 through -11, as applicable.

e. The kennel building shell for permanent kennels will be constructed in accordance with figure 7-1. A wood truss may be used in place of steel.

f. An acoustic reduction of approximately 45 decibels will be provided between the kennel and support areas, and between the multipurpose room and any offices.

g. Slope of the floors of kennel runs will be 1/4-inch per foot, and drains should be trapped and connected to waste systems by 6-inch diameter pipe.

7-5. Kennel site selection

Kennels should be located outside built-up areas whenever possible. It is not necessary for the kennels to be located in remote or isolated areas. The kennel site should be located as near as possible to utility (water, sewer, gas, and electricity) sources. Natural barriers are useful in reducing noise and visual distractions. Where there are no natural barriers, it may be necessary to construct artificial barriers. Artificial barriers may be solid walls, wood fences, chain link fencing with privacy strips weaved into the chain link, or other suitable visual and sound barriers.

7-6. Standard permanent kennel, 4-18 dogs

a. Kennel building. The kennel building will be built to accommodate at least four MWDs (four kennels). Kennels should be modular so that additional kennels can be added in pairs if authorizations are increased. Kennels may be totally indoors or, where the climate permits, there may be both an indoor and an outdoor kennel run separated by a guillotine-type door. A sample floor plan for an indoor kennel is shown at figure 7-2.

b. Kennel support building. Where new construction is necessary, room dimensions and the overall dimensions of the kennel support building will not exceed the limits prescribed in paragraph 7-9. Four sample floor plans for a kennel support building are shown in figures 7-3 through 7-6, which range in size from 435 square feet to 875 square feet. Many other designs are possible. The specific layout of a kennel support building may be varied to meet local requirements, including isolation kennels where they are needed.

7-7. Large permanent kennel, 19 or more dogs

An example of a large permanent kennel is shown at figure 7-7.

a. The kennel building will be built to accommodate at least 20 MWDs. Kennels should be modular so that additional kennels can be added in pairs if authorizations are increased. Kennels may be totally indoors or, where the climate permits, there may be both an indoor kennel or an outdoor kennel run separated by a guillotine-type door. The kennel building includes the food preparation and storage room.

b. Where new construction is necessary, room dimensions and the overall dimensions of the kennel support building will not exceed the limits prescribed in paragraph 7-9. Many kennel support building designs are possible. The specific layout of a kennel support building may be varied to meet local requirements, including isolation kennels where they are needed.

7-8. Semipermanent kennel

Semipermanent kennels may be provided in overseas areas having climates within the tolerances described in paragraph 7-13. The semipermanent kennel may be located adjacent to the PM's office or some other office that is continuously occupied by personnel who are able to care for and protect the dogs. A small house trailer may also be used as a support building to provide a food preparation and storage area, a tack room, and an office for the kennelmaster. An example of a semipermanent kennel is shown at figure 7-8. Detailed designs for temporary kennels intended for use in the theater of operations or other overseas contingencies are found in TM 5-302 (Army Facilities Components System - Designs). The associated bills of materials are found in TM 5-303 (Army Facilities Components System Logistics Data and Bills of Material).

a. The kennel for each dog is constructed of chain link fencing with minimum dimensions of 5-feet 6-inches wide by 12 feet long by 6 feet high. All kennels will have a top guard or a section of fence fastened to the top of the kennel to keep the dog from climbing or jumping out. Prefabricated sections of chain link kennels are available from civilian manufacturers and provide an acceptable kennel. Prefabricated sections are assembled by bolting the corners together. The prefabricated kennel also includes a pre-hung door.

b. Each kennel will be equipped with a doghouse for the dog. Overall dimensions should be 48 inches long by 36 inches wide by 30 inches high. A heating capability will be provided to maintain the doghouse above 35 degrees Fahrenheit during cold weather. Sufficient open shelter should be provided to the kennel so the dog is protected from direct sunlight without reducing the horizontal airflow when the temperature exceeds 85 degrees Fahrenheit.

c. The floor of the kennel will be sealed concrete or pea gravel. Animal wastes will be collected and disposed of in a sanitary manner at least twice daily. If the temperature is above freezing, the kennel floor should also be washed after disposing of wastes.

d. Each kennel will be separated by an opaque barrier fastened to the chain link fencing material to keep the dogs from agitating each other.

7-9. Kennel support building size limits

Kennel support buildings exist to support the operation of the kennel, the daily training of the MWD teams, and the operational missions involving MWD teams. To avoid unnecessary new construction cost, size limits for kennel support buildings have been established. New construction will not exceed these size limits. Kennel designs should provide only the minimum necessary space to perform required functions. Size shall be in accordance with table 7-1.

Table 7-1
Kennel support building size limits

Room or area	Semipermanent Kennel	Standard Kennel	Large Kennel
Food preparation room with counter, sinks, refrigerator, stove, food cart, and storage racks	60SF	80SF	100SF
Food storage room with sufficient space for 30-day supply of food for dogs.	40SF	40SF	80SF
Isolation kennel (optional).	NA	50SF	100SF
Kennelmaster Office.	NA	100SF	100SF
Latrine with sinks, toilets, and showers.	NA	60SF	120SF
Maximum overall size of kennel.	200SF	1000SF	1400SF
Mechanical equipment room for furnace, water heater, etc.	40SF	40SF	70SF
Multipurpose room—ready room, briefing room, classroom, emergency exam and treatment room.	NA	150SF	250SF
Other closets and storage room, each room.	NA	35SF	35SF
Other offices—permanent kennels only, each office.	NA	100SF	100SF
Tack room with shelves and racks for equipment.	NA	40SF	80SF

7-10. Ventilation system

a. The ventilation system in the kennel building will be separate from the system for the kennel support building. At least six air changes per hour are required for the kennel building and at least one air change per hour in the kennel support building. Latrines and isolation kennels will be ventilated by individual systems to avoid mixing with the air in the remainder of the kennel facility.

b. Venturi ventilation is the concept that has been applied to the shell design of the kennel building. If construction is according to the building shell plans, the natural ventilation will normally be adequate to achieve the necessary air movement through the kennel building to maintain the dogs in good health. The Venturi ventilation concept requires that the kennel building be constructed on an east-west axis with both the east and west ends of the building totally enclosed. The kennel building faces north or south. If the building is not oriented correctly or if there are other factors which interfere with the natural air flow, some auxiliary air movement systems (fans) may be necessary.

c. The minimum effective air flow required for control of moisture condensation under severe conditions is 0.8 to 1.0 cubic feet per minute (CFM) per square foot of floor area.

d. Circular metal roof ventilators (fans) or a continuous ridge may be installed on the top of the kennel building depending on local ventilation requirements. Any roof ventilator used should be capable of being opened and closed manually. A 12-foot ladder should be provided for access to the catwalk to service the ventilators. Forced air reversible fans work well.

e. Each dog kennel within the kennel building may be constructed with a window that could be opened in the event of a ventilation system failure and to admit natural light. The window should be outside the kennel cage. Kennels with both an indoor and an outdoor section separated by a guillotine-type door are also adequate.

7-11. Heating

a. The kennel building will be heated for frigid zone kennels. Heating will be by floor radiant heat providing a slab temperature of not less than 35 degrees Fahrenheit and not more than 55 degrees Fahrenheit during heating season.

b. Heating of the remainder of the kennel building and the kennel support building will be by the most economical heating system according to human standards. Solar heating applications shall be evaluated in accordance with ETL 1110-3-3xx, Evaluation of Renewable Forms of Energy, dated 3 Aug 83. Other heating systems include low temperature radiant heating system only, radiant heating plus domestic hot water, or domestic hot water only.

c. For cold climates, glazed closures should be provided for all exterior screened areas.

7-12. Air-conditioning

When air-conditioning is authorized, it will be provided in the kennel support area, including the food preparation and storage areas, only. The kennel area of the kennel building will not be air-conditioned.

7-13. Temperature climate kennel

A temperature climate kennel building will be built where the design ground snow load is 20 pounds per square foot or less or where the mean annual heating days are less than 5501.

a. The kennel area will be an enclosed area with a 5-foot wide central corridor or aisle, double loaded with kennels 5-feet 6-inches wide by 8-feet long each. Outdoor runs, 5-feet 6-inches wide by 8-feet long, will be connected to each indoor kennel. The outdoor run will be protected by a 4-foot roof overhang.

b. The indoor kennel and the outdoor run will be separated by a guillotine-type door, operable from the central corridor, to allow isolation of the dogs during cleaning operations.

c. The outdoor runs should be sloped to a gutter located immediately outside of the end fence of each run. Indoor kennels should be sloped toward center aisle drains.

d. All areas within the kennel building should be protected with insect screening.

7-14. Frigid climate kennel

The frigid climate kennel may be used where the design ground snow load is more than 20 pounds per square foot or where the mean annual heating degree days is more than 5500.

a. The kennel building will be completely enclosed with a 5-foot wide central corridor or aisle, double loaded with kennels 5-feet 6-inches wide by 8-feet long each.

b. A gutter and drain will be provided between the inside kennel building wall and the back of each kennel run for sluicing waste waters during kennel cleaning. The space between the wall and back of the kennel runs should be at least 2 feet. Drain gutters should be wide enough to be easily cleaned.

c. The kennel floor will be sloped (at least 1/8-inch per foot) to the gutter to allow for quick water drainage and drying. Drain traps should be deep enough to prevent freezing of water in cold weather.

d. The kennel building design must include ground level ventilation. Venturi ventilation or normal height windows are not sufficient to dry kennel run floors during cold weather.

7-15. Plumbing

A potable water supply (hot and cold water) will be located in the food preparation area. Potable water is water which has been approved for human consumption. If water lines are not available, a water trailer and immersion heaters must be provided.

a. A hot water heater will be installed to provide sufficient hot water for authorized dogs and handlers.

b. Kennel building water lines will be installed at ceiling level with drop connection lines at least every 50 feet.

c. The sinks in the food preparation room should be the deep, laundry-type basins.

d. All floor drains will be at least 6-inches in diameter. An isolation kennel will have at least one 6-inch floor drain located outside the kennel.

e. Gutters between indoor and outdoor kennels make cleaning easier. Half round pipe permits the dog to walk through. All gutters should be flushed immediately after cleaning with potable water to prevent sanitation problems. Kennel runs on both sides may be cleaned from the center aisle.

f. Attachment of the kennel plumbing system to a sewer system is highly recommended. A 100-gallon septic tank must be emptied daily for 50 dogs.

7-16. Lighting and electrical systems

Receptacle circuits in areas to be washed down or subjected to spraying will be provided with ground fault circuit interrupters. All electrical sockets (inside and out) will be the all-weather type with a spring cover.

a. Lighting in the kennel building will be 10-foot candles and in the multipurpose room at least one area should be 70-foot candles. Lighting in the remainder of the kennel facility will conform to the requirements of DOD 4270.1-M, and Illuminating Engineering Society (IES) lighting handbook.

b. Lighting in the kennel building is required for safety and security.

c. Outside security lighting should be sufficient to provide a lighted perimeter around the kennel facility to prevent an unauthorized intrusion.

7-17. Public address system

A public address system should be provided between the kennelmaster's office, the kennel building, and the outdoor training and exercise areas. The public address system should consist of one master station and an appropriate number of speakers.

7-18. Structural safety and security

a. Gates and metal frames should be constructed from square tabular metal rather than angle iron. Chain link spot-welded to angle iron is easily torn loose by aggressive or bored dogs. Tabular metal gate and kennel frames are significantly more maintenance free.

b. Kennel run gates and kennel building doors will be self-closing.

c. All kennels will have chain link fencing installed over the top of the kennel to prevent the dog from climbing or jumping out.

d. Water-type fire extinguishers must be provided for each 2500 square feet of floor space in the kennel and support buildings.

e. At least two doors or gates should separate the dog from unrestricted public areas.

7-19. Kennel partitions

A full height concrete partition will be provided between all kennel runs. A 4-foot high, germ and urine resistant, glaze coated wainscot will be provided on all masonry walls. All areas accessible to dogs will be finished with materials that are resistant to damage by scratching, biting, and chewing. Materials selected should provide the minimum maintenance and maximum sanitation possible. Paint and epoxy compounds are not usually effective.

7-20. Louvers

Louvers are installed on the fixed portion of the kennel face on opposite sides of the center aisle between kennels so that dogs are unable to directly observe each other. Louvers are installed to extend from the floor to at least 4 feet high. Louvers are used so as not to interfere with natural ventilation. Louvers normally are not needed on the gate. Gate entrances to kennels are alternated so dogs will not be in direct line of sight with the kennel on the opposite side of the corridor. (See fig 7-2.)

7-21. Kennel building floor

a. All floors in kennels and isolation kennels will be sealed concrete.

b. All floors will be sloped toward drains and/or gutters to provide rapid run-off of water and rapid drying. Floor drains and gutters are located outside the kennel runs.

7-22. Kennel fixtures

a. One pallet will be provided for each dog. Pallets will be wolmanized wood or other hardwood to resist insect infestation and chewing by the dog. Commercially manufactured hard plastic kennel pads may be acceptable for use with dogs, but should not be used until evaluated and approved.

b. A bucket holder will be provided for each kennel for each dog. A hoop that encircles the bucket or a double snap holder are both acceptable because they prevent the dog from overturning the water bucket.

7-23. Fencing

Standard chain link fencing 8-feet high will be used to enclose the training area, and all entrances to the kennel building. A top guard (of plain wire, not barbed wire) should be installed to prevent a dog from climbing or jumping out. Each outside entrance of the kennel building will be enclosed to provide a space not less than 15 feet by 15 feet and an outside self-closing gate. NATO standard fencing or Type FE-5 (OCE Drawing 40-16-08) are both suitable for all fencing requirements.

7-24. Parking and sidewalks

- a.* Parking will be limited to no more than eight stalls in front of the kennel support building. A gravel surfaced access drive should connect the parking area with the training area.
- b.* One concrete sidewalk will be provided between the parking area and the main entrance to the kennel support building. A pea gravel path may be provided around the kennel building and kennel support building.
- c.* Walkway planning should consider the need for dog team traffic in and around the kennel facility to be one way to avoid confrontation between dogs.

7-25. Training area

An enclosed, secure training area is required to provide a location where training can be held in advanced obedience, confidence training, and correction of deficiencies in off-leash control. To simplify transportation requirements, the training area should be located near the kennel building. All training areas should be constructed according to the following standards:

- a.* The entire training area should be enclosed using standard chain link fencing. The fencing must have one or more entry gates with an automatic latching device that securely latches the gate when it closes.
- b.* The surface of the training area must be free of objects that may be harmful to the dogs or handlers, such as rocks, broken glass, holes, and sand burrs. The surface should be graded or sloped to prevent standing water.
- c.* The size of the training area should be at least 80 feet by 100 feet to give adequate room for off-leash training exercises.
- d.* An obedience course, as illustrated in figure 3-1, should be built in the training area or in an adjacent training area. The obedience course obstacles may be built from salvaged materials. Each obstacle must have padding and a nonskid surface to prevent injuries to the dogs. Specifications for the obstacles are provided in paragraph 7-26.
- e.* Training areas must be kept clean, all obstacles in good repair, and vegetation closely trimmed. Stools must be removed at the end of each training session.

7-26. Obedience course

The obedience course obstacles are constructed according to the specifications provided in figures 7-9 through 7-14. Figure 7-9 gives the dimensions of the three barrels and tunnel. Figure 7-10 gives the specifications for the steps. Figure 7-11 gives the specifications for the three jumps. Figure 7-12 give the specifications for the window obstacles. Figure 7-13 gives the specifications for the "A" frame. Figure 7-14 gives the specifications for the dog walk.

7-27. Exercise area

The exercise area is an area where the dog can be released by itself. Only one dog is allowed in the exercise area at a time. The area should be at least 20 feet by 20 feet enclosed by standard 8-foot high chain link fencing. The surface of the exercise area should be sloped to prevent the accumulation of standing water, and the area should be free of all objects that may be harmful to the dog.

Section II

Maintenance and Sanitation

7-28. Kennel maintenance

- a.* Proper maintenance of kennels requires early detection and correction of all deficiencies, safety, and health hazards. Kennels must be carefully inspected daily by the kennelmaster and each of the assigned handlers. Loose or worn hinges, catches or rollers, broken wire or anchor fasteners, and any other broken or damaged equipment must be promptly repaired. Wood pallets must be checked for broken boards, splinters, mold, signs of chewing or insect infestation, and replaced or repaired as necessary.
- b.* Kennel runs are cleaned out daily to remove debris and stools, and washed out daily to remove urine, dust, and stains. Drain troughs are provided outside each run to provide proper drainage.
- c.* Special cleaning of kennel runs using hot water and detergent, or steam cleaning, must be done at least weekly. All areas will be thoroughly rinsed with potable water after cleaning. A chemical sanitizing agent (disinfectant) which has been approved by the veterinarian will then be applied to control infectious bacteria and offensive odors.
- d.* Insects and rodents can be controlled by immediate disposal of all waste material. Rodents are attracted by dry meal and food scraps. All foodstuffs must, therefore, be stored in rodent-proof containers. Tall grass, weeds, and brush will be removed from areas that harbor ticks and other insects, preferably by controlled burning under fire department supervision. Vegetation should be removed from around the kennel to a distance of at least 10 feet. The area should then be sprayed with a residual insecticide, approved by the veterinarian. The kennel area, the food preparation and storage area, and any other appropriate area also will be sprayed periodically with a residual insecticide prescribed by the veterinarian.

Section III

Kennel Safety and Transportation of Dogs

7-29. Warning signs

Warning signs, which must be posted on exterior fencing and buildings of the kennels and training area, are prescribed in AR 190-12.

7-30. Safety measures and procedures

a. Consistently practicing safety in the kennel and training area is a direct measure of the professional skill, motivation, and credibility of every handler, kennelmaster, and supervisor of an MWD kennel facility. Freedom from careless accidents builds public confidence in the individual and collective abilities of all handlers, and helps build a favorable impression of the MWD program among the members of the Army served by the MPs. Although MWD are trained to be tolerant of other personnel and dogs, the constant activity in kennel areas tends to excite the dogs. Positive control must be maintained to prevent a dog from getting loose and injuring a person, another dog, or itself. Safety is every handler's personal responsibility.

b. Personnel must not run or horseplay in or near kenneled dogs. This activity agitates the dogs and could result in a dog mistaking the actions with actual hostility, thus causing an attack.

c. Personnel must make sure they secure all gates after use, avoid sudden movements when passing dogs, and not speak or move in any threatening way around the dogs.

d. Handlers must keep dogs on a short leash at all times in the kennel area. If a dog gets loose, the first person to notice the loose dog must warn everyone else. Everyone except the dog's handler ceases all movement until the handler regains physical control of the dog.

e. One way traffic patterns must be set up throughout the kennel and training area to keep dogs from meeting head-on.

f. Handlers with dogs will give a verbal warning when entering or leaving the kennel area, or whenever their view is obstructed. These warnings help to prevent the dogs from being surprised by the sudden appearance of a person (and vice versa) rounding a corner or opening a door.

7-31. Training area safety

The following safety precautions are required in training areas not surrounded by fences.

a. Keep a safety leash on the right wrist while moving to and from training areas.

b. Keep a safe distance between dog teams in the area. When approaching another dog team, each dog is held in the heel position with a short leash.

c. Except when necessary for certain training exercises or while in a vehicle, the handler should not sit or lie down when accompanied by a dog.

d. Never secure the dog to an object with the leash, never stake out the dog and leave it unobserved, and never tie the dog to a vehicle. The dog can chew through or break the leash.

e. If a dog fight occurs, never attempt to stop it alone, and never attempt to pull the dogs apart. Pulling may injure the dogs.

(1) If on a leash, keep the leash taut, work the hands toward the snap of the leash, and hold the leash firmly with one hand, grasping the dog's throat with the other hand and squeezing with thumb and forefinger to cut off the dog's air supply. When the dog gasps for air, move the dogs away from each other.

(2) If off a leash, grasp the choke chain, leather collar, or the nape of the neck with one hand and with the other squeeze the dog's throat with thumb and finger to cut off the dog's air supply (the handler uses the same procedures when the dog bites a person. An attacked person should not try to jerk free from a dog's bite. Any unnecessary movement by a person will only increase the seriousness of the injury). When the dog gasps for air, move the dogs away from each other.

(3) An alert handler recognizes when a dog is about to attack, grasps the leash above the snap, holds the dog's front feet off the ground, pushes the dog away and slowly turns in a circle to keep the dog off balance.

7-32. Safety in veterinary facilities

When taken to a veterinarian, the dog is among unfamiliar surroundings and people and may behave unexpectedly. The handler must be prepared to physically control the dog while medical care is being given. The handler should always be present and immediately available to the veterinarian whenever the dog is receiving medical treatment.

a. Before entering the veterinary clinic, the handler should muzzle the dog, attach the short leash, and carefully follow the instructions of the veterinarian.

b. Before entering, the handler must give a verbal warning that an MWD is entering. In the treatment facility, the handler controls the dog with the short leash. The handler can calm the dog by speaking in a soothing, reassuring voice

to the dog. When facilities permit, MWDs will be admitted to the veterinary treatment facility through an entrance separate from that used by privately-owned animals.

7-33. Vehicle transportation

a. A cleated ramp may be used to load dogs onto a vehicle. If a ramp is not available, the handler lifts the dog on or off the vehicle by using the front and hindquarter or the stomach lift. Injured dogs may require different handling. Dogs are lifted on or off a vehicle on a short leash.

b. To place the dog in a vehicle for patrol purposes, begin with the dog at the heel or sit position. Open the door, command HUP, then SIT. A stable platform with a nonskid surface as described in para 2-4 should be used to cover the seat. The dog may be off-leash in the vehicle, but is never tied or left alone. When getting out of the vehicle, the handler commands HEEL.

c. Dogs being transported off an installation may be transported in shipping crates. If the dog is being shipped to a potentially hostile area, the crate should be painted with camouflage paint. Plainly mark the shipping crate with the dog's name and brand number, and mark in bold letters on the shipping crate "DANGER, MILITARY WORKING DOG—DO NOT TAMPER WITH ANIMAL." Handle the crate carefully to prevent it from being dropped. If a vehicle has an accident, remove the dog from the crate and check for possible injury.

7-34. Aircraft transportation

MWDs and handlers will normally be moved together. Commercial air transportation may be used when moving MWD teams interstate or to overseas commands. The following requirements apply to all movement of MWDs:

a. Handler and dog will be routed on the most direct flight by using the most cost-effective commercial air transportation. For overseas movement, Category Z or other discount fare will be used. A handler should always accompany the dog on the overseas segment of travel.

b. When handler and dog move together on PCS, the dog is declared as "excess baggage" on the Government Transportation Request (GTR). The GTR will contain the statement: "LIVE ANIMAL—MILITARY WORKING DOG."

c. When the handler takes a delay enroute in the continental United States (CONUS) (for example, leave), the dog will be shipped separately as air freight to the appropriate CONUS commercial gateway to link up with the handler. The losing unit commander is responsible for coordinating the movement of the dog and handler to ensure arrival at the airport at approximately the same time. The handler will claim his or her dog from the air freight carrier, and transfer the dog and crate to the air carrier on which they are scheduled for overseas movement. The Government Bill of Lading (GBL) will contain the statement "LIVE ANIMAL—MILITARY WORKING DOG" also. Copies of all appropriate documents, such as health certificate and vaccination records, will accompany the GBL/shipment as required.

d. All shipment of MWDs must minimize the number of stops and transfers. If possible, during hot weather, ship dogs at night. The air temperature in any holding area should not be allowed to fall below 45 degrees Fahrenheit or to exceed 85 degrees Fahrenheit at any time. MWDs should arrive at the airport as near to flight time as possible and not more than four hours prior to flight time. For CONUS moves, the shipping installation will notify the receiving installation of the carrier, the flight number, and the date and time of arrival. A handler from the receiving installation will be assigned to meet and claim an unaccompanied dog within 4 hours of its arrival.

e. The MWD will be offered potable water within 4 hours, but not less than two hours prior to flight time. Feeding and watering instructions must be affixed to the outside of the shipping crate and included on the GBL so that the dog can be cared for if there are delays enroute. Instructions will include the recommendation to provide potable water at least once every 12 hours and food at least once every 24 hours. Appropriate food should also accompany the dog and shipping crate.

f. The shipment must also comply with conditions specified in subpart A, part 3, subchapter A (Animal Welfare), chapter 1, title 9, Code of Federal Regulations.

g. When making booking, transportation officers/port call activities should ensure that the airline is advised that the passenger is authorized excess baggage consisting of a metal shipping crate, a live animal, and its food. Provide the total weight, the number of pieces, and the dimensions of each piece.

h. Local procedures should be established to ensure that necessary information on port call is provided to all persons involved; that is, the handler, the kennelmaster, the unit commander, the central port call office (CPCO), and the transportation officer. When the dog is shipped air freight, other movement information (carrier(s), flight number(s), date(s), and time(s) of departure and arrival) will be provided by priority message (and by phone, if possible) to the Military Traffic Management Command (MT-PTO-T), to the Military Air Traffic Coordinating Unit (MATCU), the installation/activity nearest any connecting airport, and the gaining unit/installation, as appropriate. The appropriate personnel assistance point (PAP) will be an information addressee on the message.

i. MTMC will provide additional guidance as necessary to ensure maximum visibility of the movement of MWDs including, but not limited to, air carriers and assistance that can be provided by MATCUs, air carriers, and air

terminals. Where international movements are involved, location of MATCUs will be a factor in the routing determination.

j. As a general rule, movement of dog and handler together is funded from the Military Personnel, Army (MPA) account. Movement of the dog alone is funded from the operation and maintenance, Army (OMA) account.

k. All movement of patrol-trained dogs should be accomplished using the standard metal shipping crate. The lighter, fiberglass shipping container may be used for nonpatrol-trained detector dogs and for the small breed detector dogs.

7-35. Hot weather requirements

a. When transporting dogs in shipping crates, use air-conditioned or well ventilated vehicles, give the dogs adequate and frequent supplies of fresh, cool water, and in case of vehicle breakdown, unload each dog from the vehicle and locate in a nearby shady, cool area.

b. Load crates so that the dogs will get maximum ventilation. Never place baggage, other crates, or equipment on top of or around a crate. Never load dogs into crates that have been standing in the sun.

c. Check dogs often to be sure they are not becoming overheated.

7-36. Leaving dogs unattended

Dogs should never be left unattended except when they are put in their kennels. There are times, however, when they must be left unattended for short periods. When this becomes necessary, the rules below must be followed:

a. Use only the leather collar and a kennel chain to stake out a dog. Do not use the choke chain and leash.

b. Do not secure a dog to a vehicle or an object that can be moved, or may accidentally move.

c. Do not stake out a dog in a location where it could injure itself or others.

d. Make sure that the dog is located in a shady area during hot weather.

e. Check the dog often to make sure that it is not in distress.

Section IV

Security Requirements for Kennels

7-37. Risk analysis

In order to provide the most realistic and cost-effective protection for the MWDs and kennel facility, commanders must appreciate the importance and analyze the significance of the threats to these assets because of theft, sabotage, or damage. A proper analysis of these risks will determine the minimum level of protection needed to adequately safeguard these resources. This process is called risk analysis. The principles of risk analysis (see AR 190-51) apply to the determination of measures which must be taken to protect the kennel and dogs from criminal activity.

7-38. Designing for security

Many passive security measures, such as lighting, barriers, and structural integrity, can be provided merely by including them in the design and construction of the kennel facility. All access points to the kennel facility can be designed to prevent unauthorized access. Security can be provided in depth to delay an intruder from reaching his or her objective. The facility can be located in an area that provides a reasonable degree of natural security from terrain features or from its proximity to other installations. Although a patrol dog will provide an early warning of an intruder, a patrol dog confined in a kennel can do very little to prevent an intruder from taking kennel property or from harming the dogs. Some of the security design depends on the types of materials or equipment which will be maintained in the kennel facility. For example, if training aids will be stored in or near the facility, special safety and security requirements exist to protect explosives and narcotics. Structural security decisions depend on the identification of the assets which will be maintained in the kennel facility, the importance of these assets to the accomplishment of the operational mission, the identification of the significance of the threat to these assets, and the appropriate measures to counter the threats.

7-39. Operational security

Operational security is achieved by identifying the appropriate measures and procedures which are necessary to protect the dogs and the kennel facility. Important elements of operational security are as follows:

a. Controlling access to the facility.

b. Controlling access to certain areas of the facility.

c. Security awareness by the handlers.

d. The active application of security principles to handler activities in and around the kennel.

e. Property accountability.

f. The security and accountability of training records.

g. Careful daily inspection of the dogs and the kennel area.

7-40. Minimum kennel security requirements

a. As a general rule, kennels should be manned both day and night. Full-time coverage provides:

- (1) Immediate response to any attempted unauthorized intrusion.
- (2) The capability to render immediate attention to a dog that is in physical distress.
- (3) The ability to seek immediately veterinary medical assistance.
- (4) A continuous ability to feed, water, and care for the dogs.

b. Despite these reasons, there may be situations when it is not possible or practical to provide full-time coverage of the facility. In this event, appropriate compensatory measures are necessary to protect the dogs, the equipment, and the facility. Some form of an IDS and CCTV needs to be installed in the kennel facility. Although motion sensors in the kennel building are not practical, there are other sensors, such as contact switches, and pressure grids that would provide warning to a security force. CCTV would allow the monitoring of MWDs to identify any problems. Frequent checks of the facility should be made to ensure that one of the dogs does not need medical attention. Care must be exercised during these checks to not overly excite the dogs or the lack of rest may interfere with their performance. All other compensatory measures, as justified by risk analysis, should also be applied. The lighting and fencing requirement, included in the engineering instruction for kennels in section I above, may be augmented as necessary. Doors and locking hardware should be consistent with the structural security requirements for buildings in AR 190-51. Keys must be readily available in case of an emergency. Fresh water must be provided at least every 8 hours for dogs confined in their kennels. Narcotics and/or explosives training aids will not be stored in unattended facilities unless:

- (1) The storage room and container are protected by an IDS.
- (2) The standards of AR 195-5 and AR 190-11 are met for narcotics or explosives, respectively.

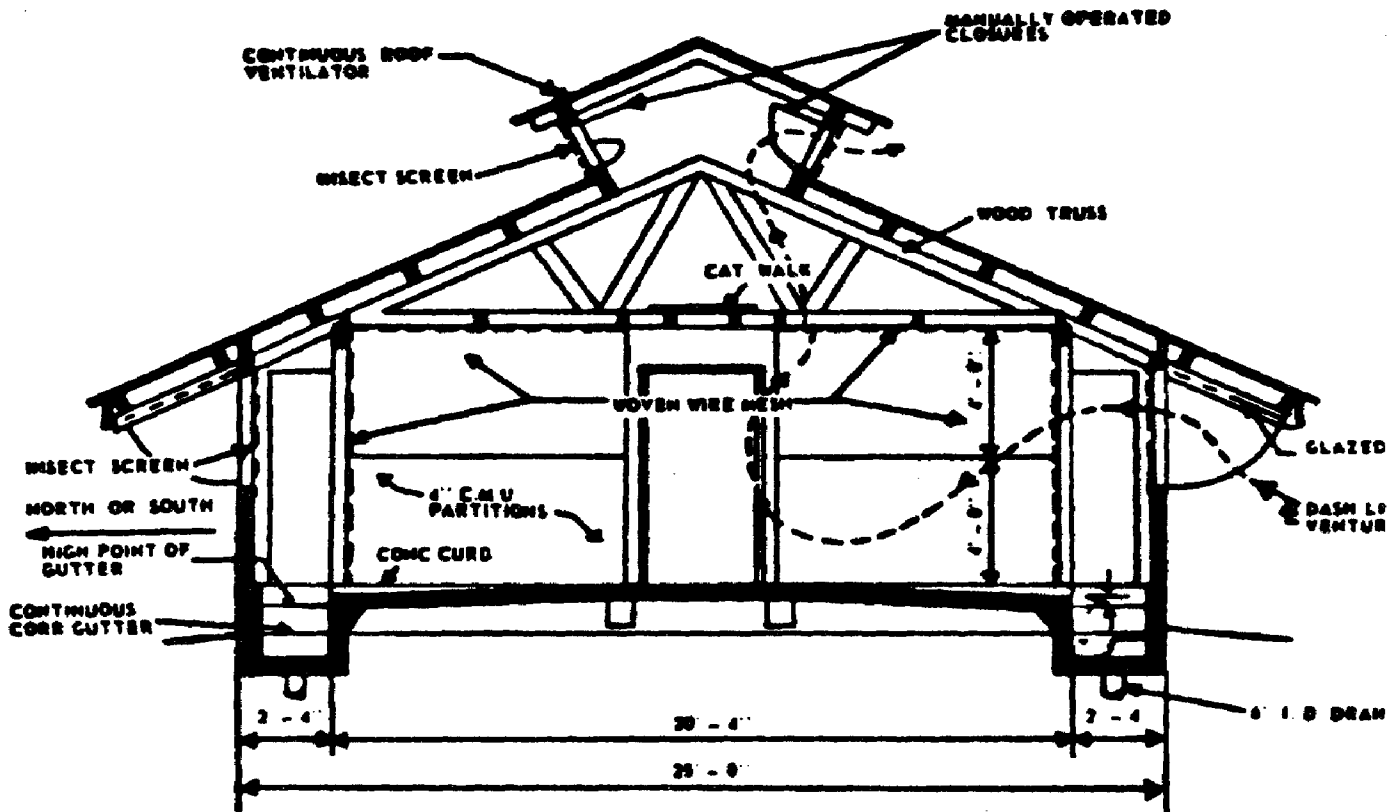

Figure 7-1. Standard kennel building shell

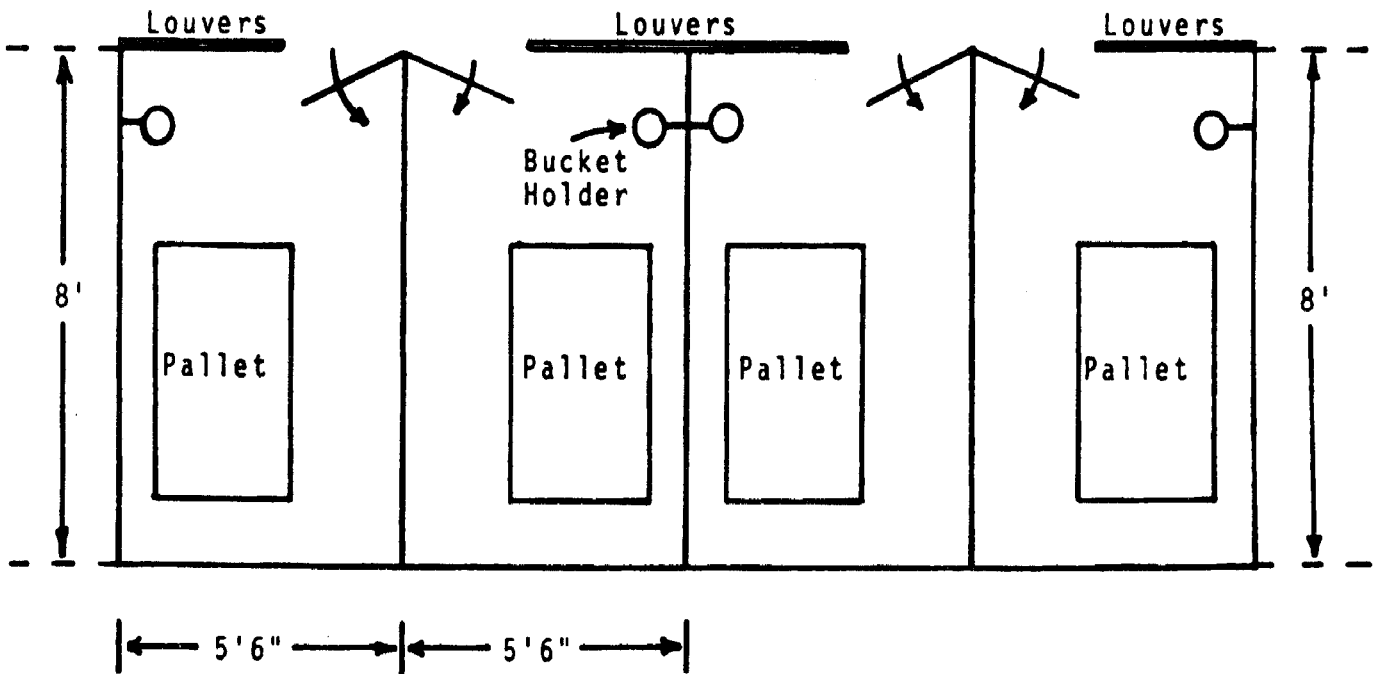
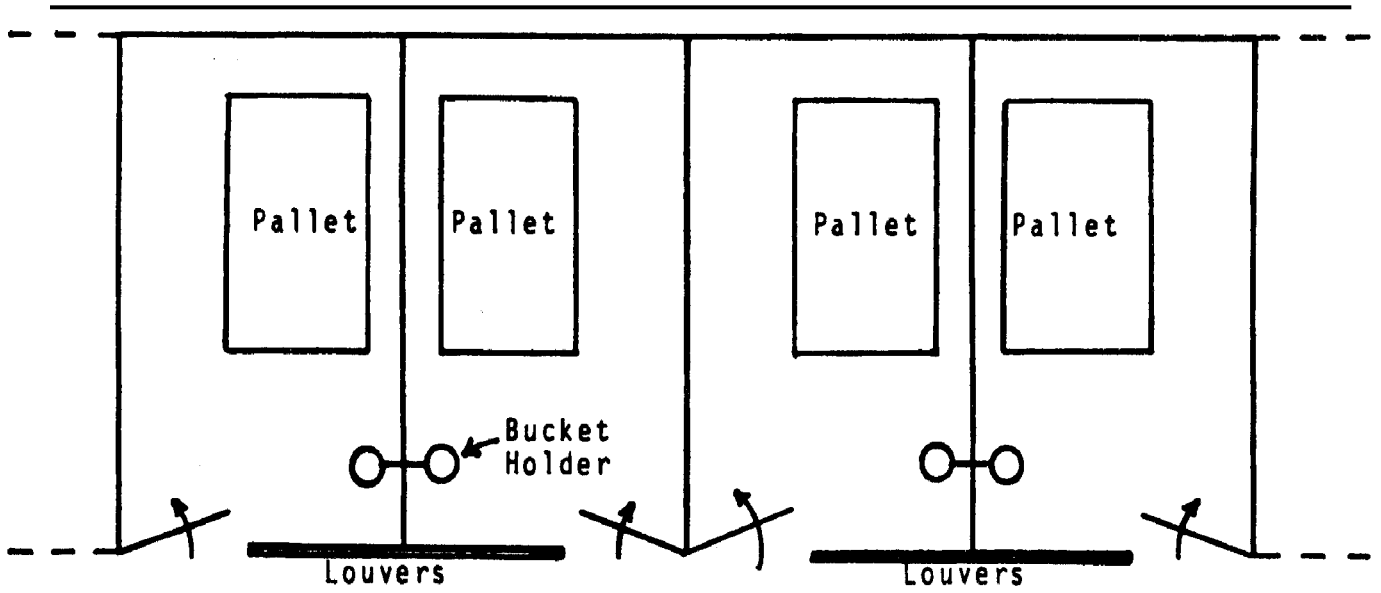
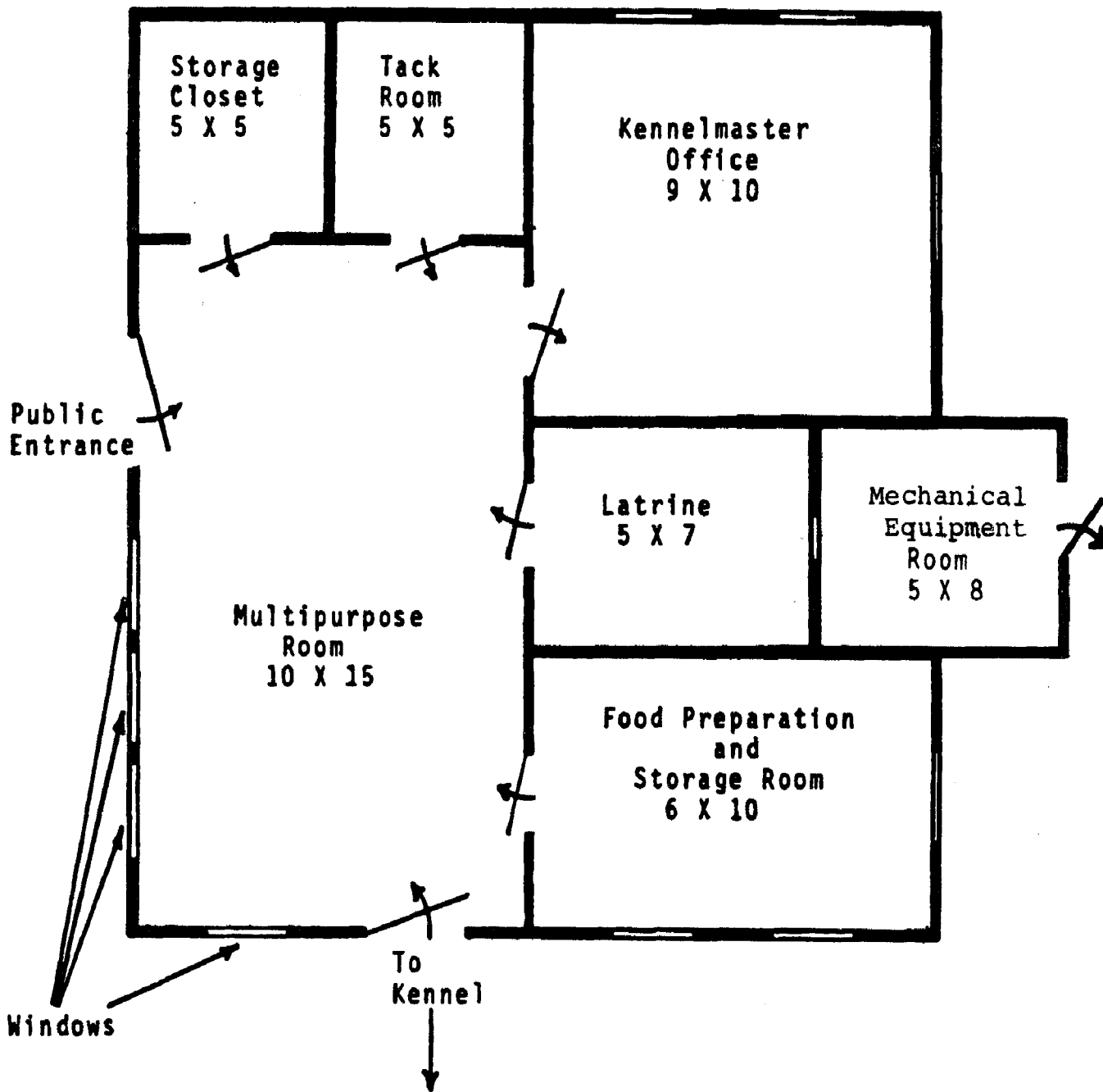

Figure 7-2. Sample floor plan, indoor kennel



NOTE:

All measurements are in feet

Figure 7-3. Sample kennel support building, 435SF

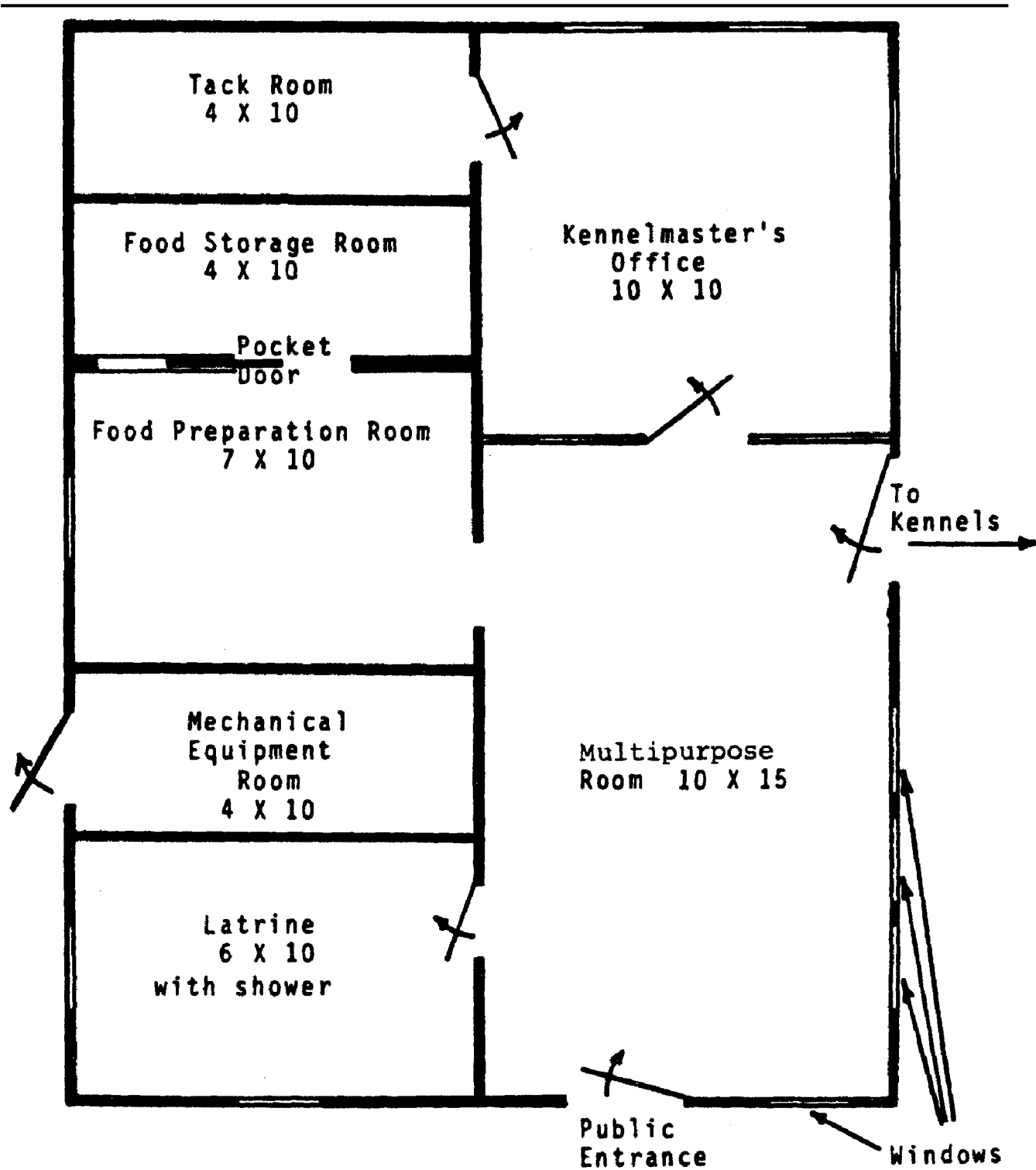

NOTE:
All measurements are in feet

Figure 7-4. Sample kennel support building, 500SF

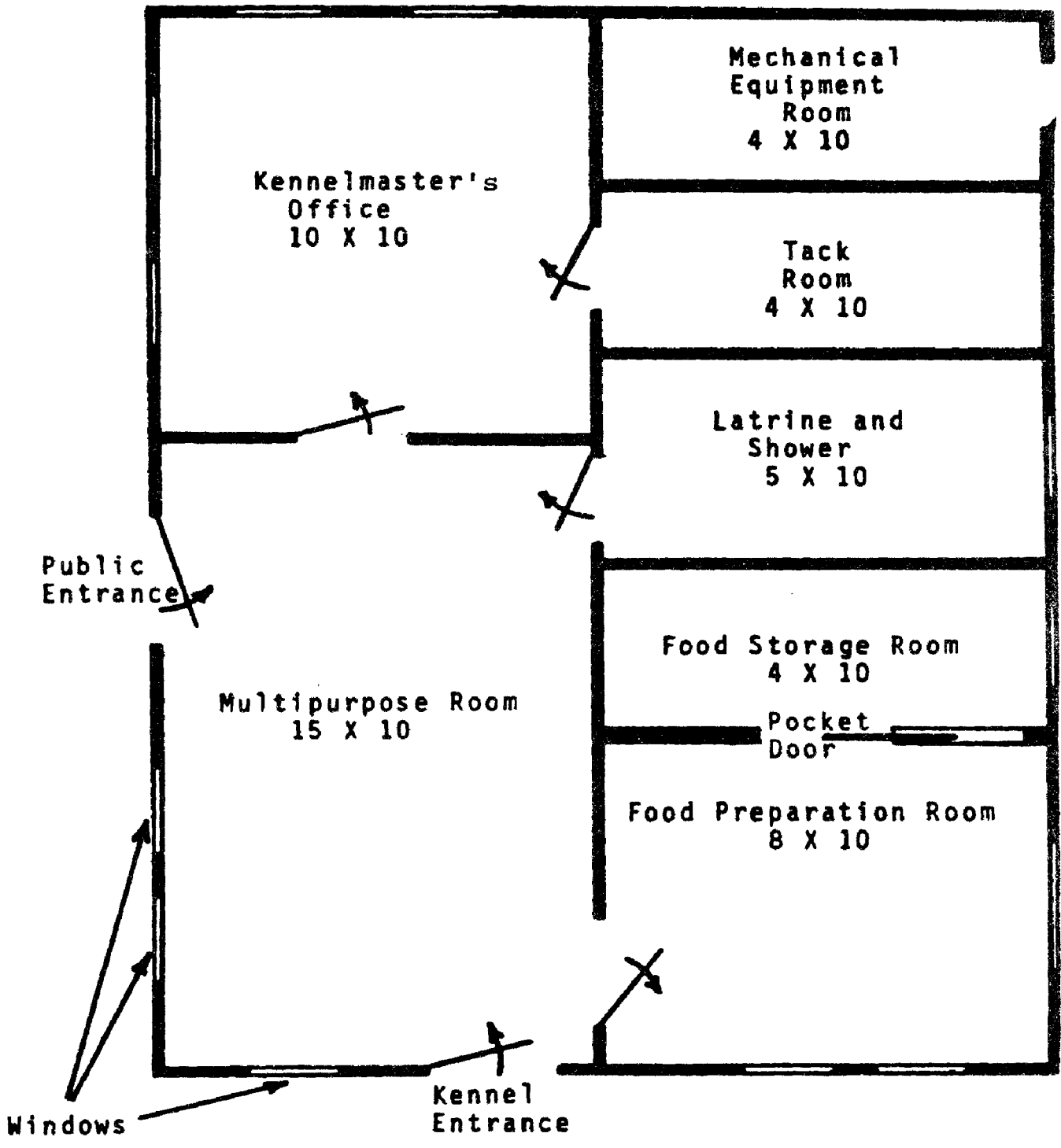

NOTE:
All measurements are in feet

Figure 7-5. Sample kennel support building, 500SF

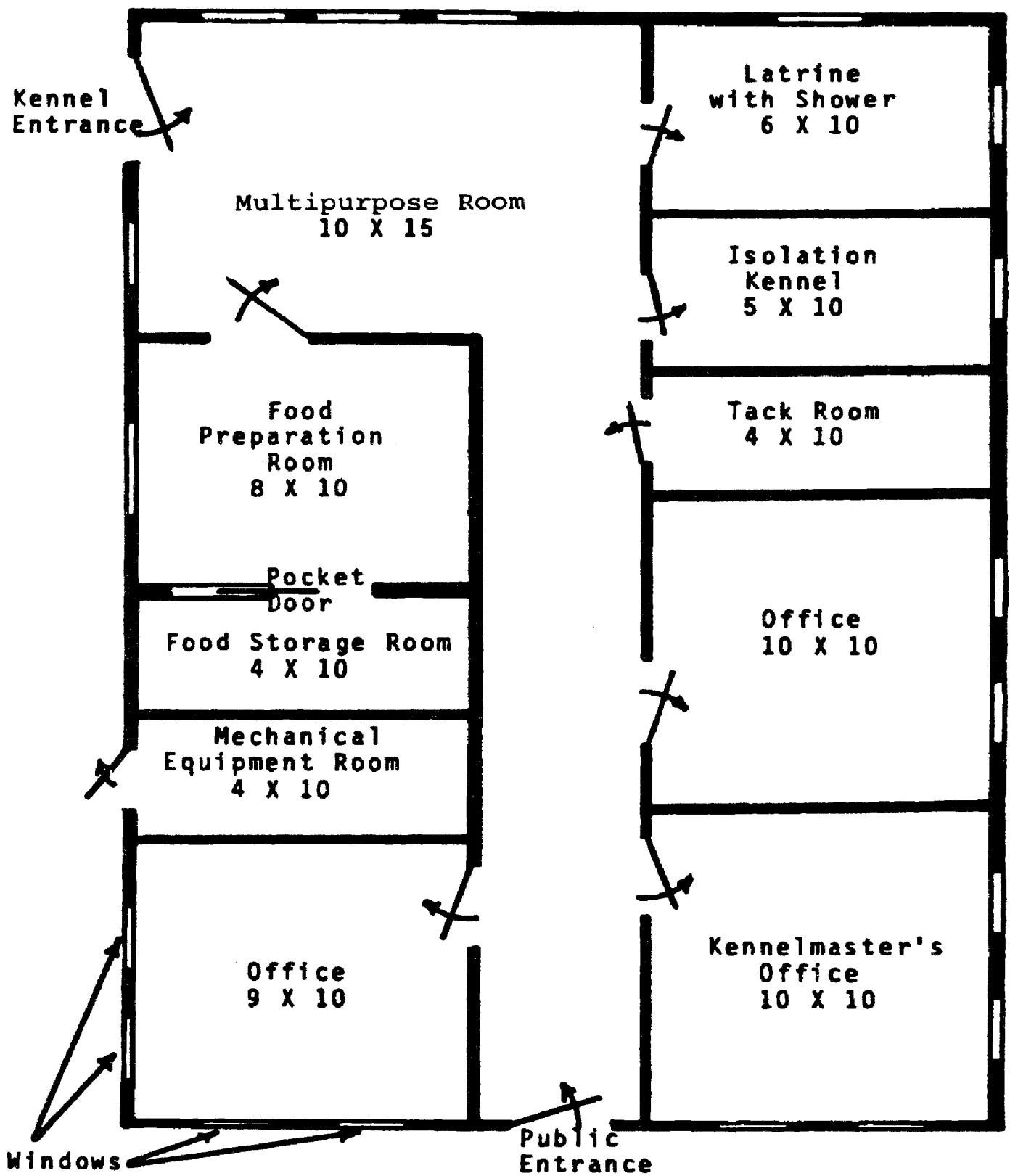

NOTE:
All measurements are in feet

Figure 7-6. Sample kennel support building, 875SF

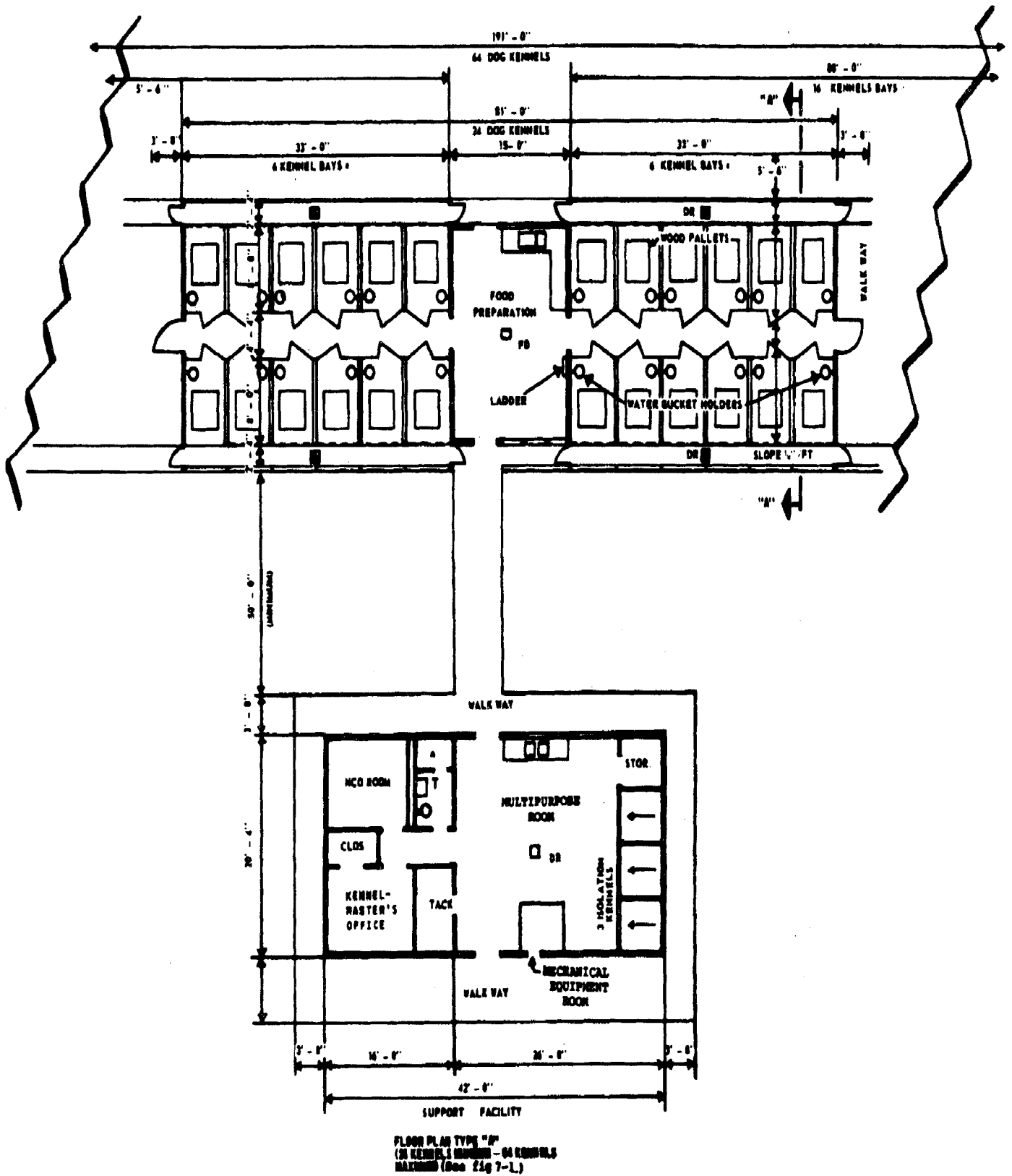
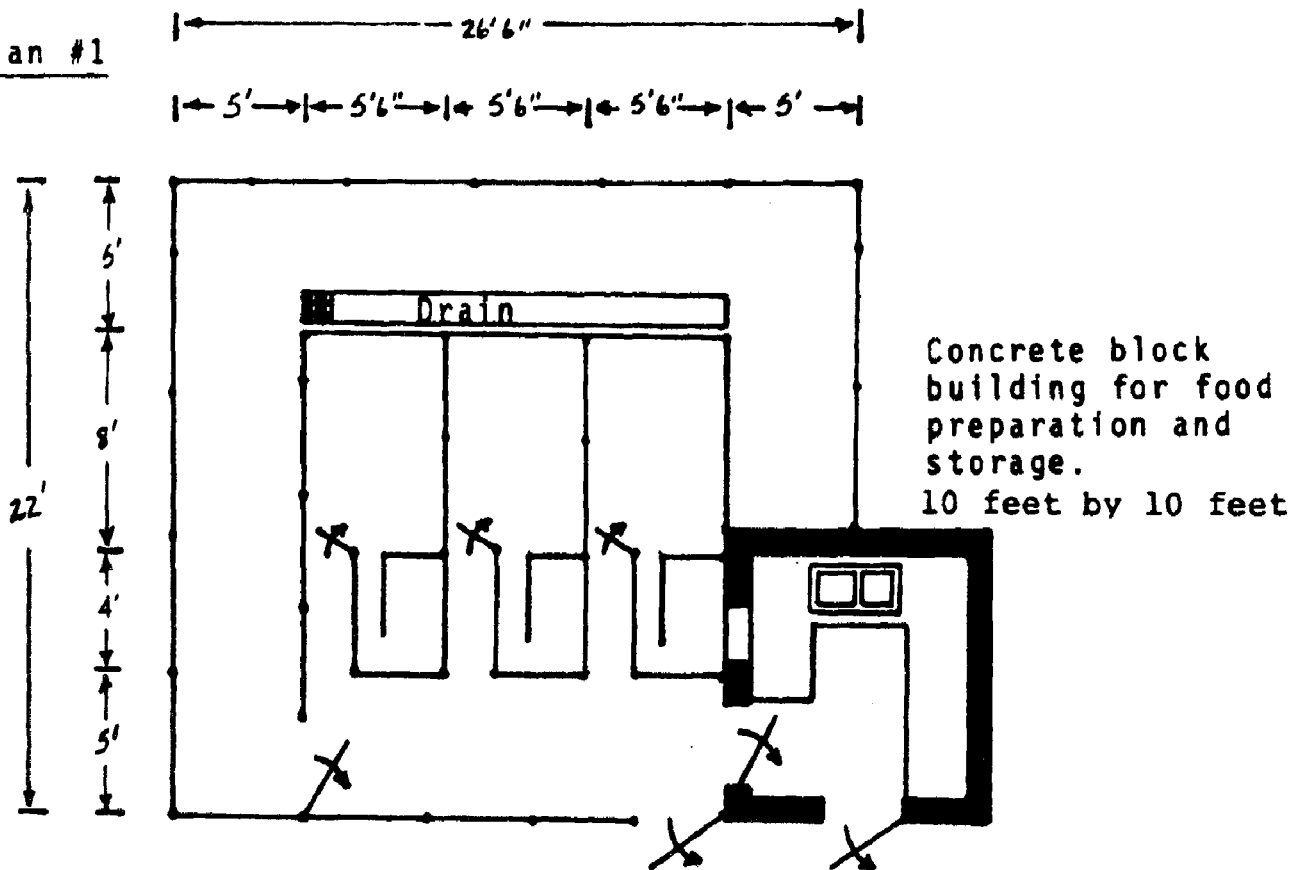

Figure 7-7. Large permanent kennel

Plan #1



Kennels constructed on concrete pad, 17 feet by 16 feet 6 inches, including a 5 foot apron in front. Kennel and a 5 foot strip around kennel enclosed by chain link fence.

Plan #2

Kennels constructed on concrete pad, 12 feet by 16 feet 6 inches, completely enclosed by chain link fence.

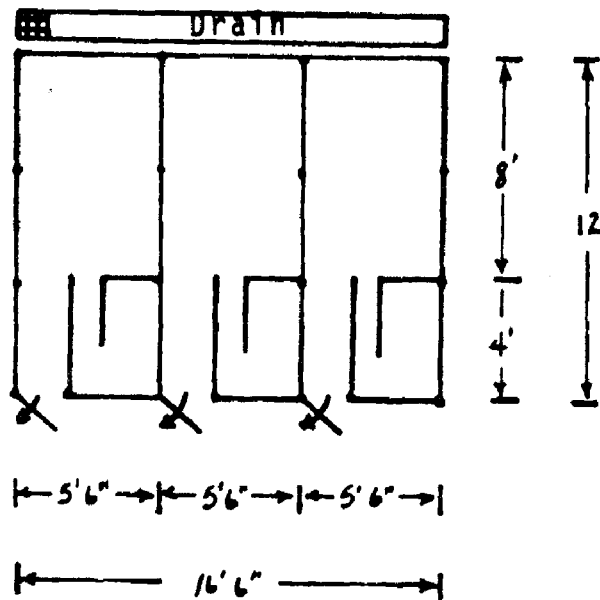
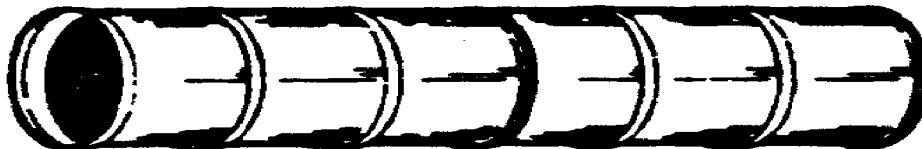

Figure 7-8. Semipermanent kennel



Barrel No. 1

Length = 35 inches
Opening = 23 inches



Barrel No. 2

Length = 70 inches
Opening = 23 inches

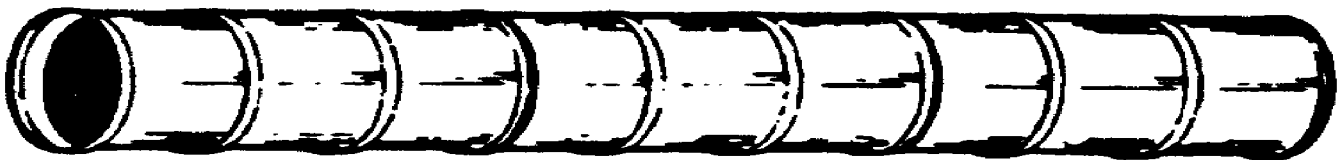

Barrel No. 3

Length = 105 inches
Opening = 23 inches



Tunnel

Length = 146 inches
Opening = 19 inches

Figure 7-9. Specifications for barrels and tunnel

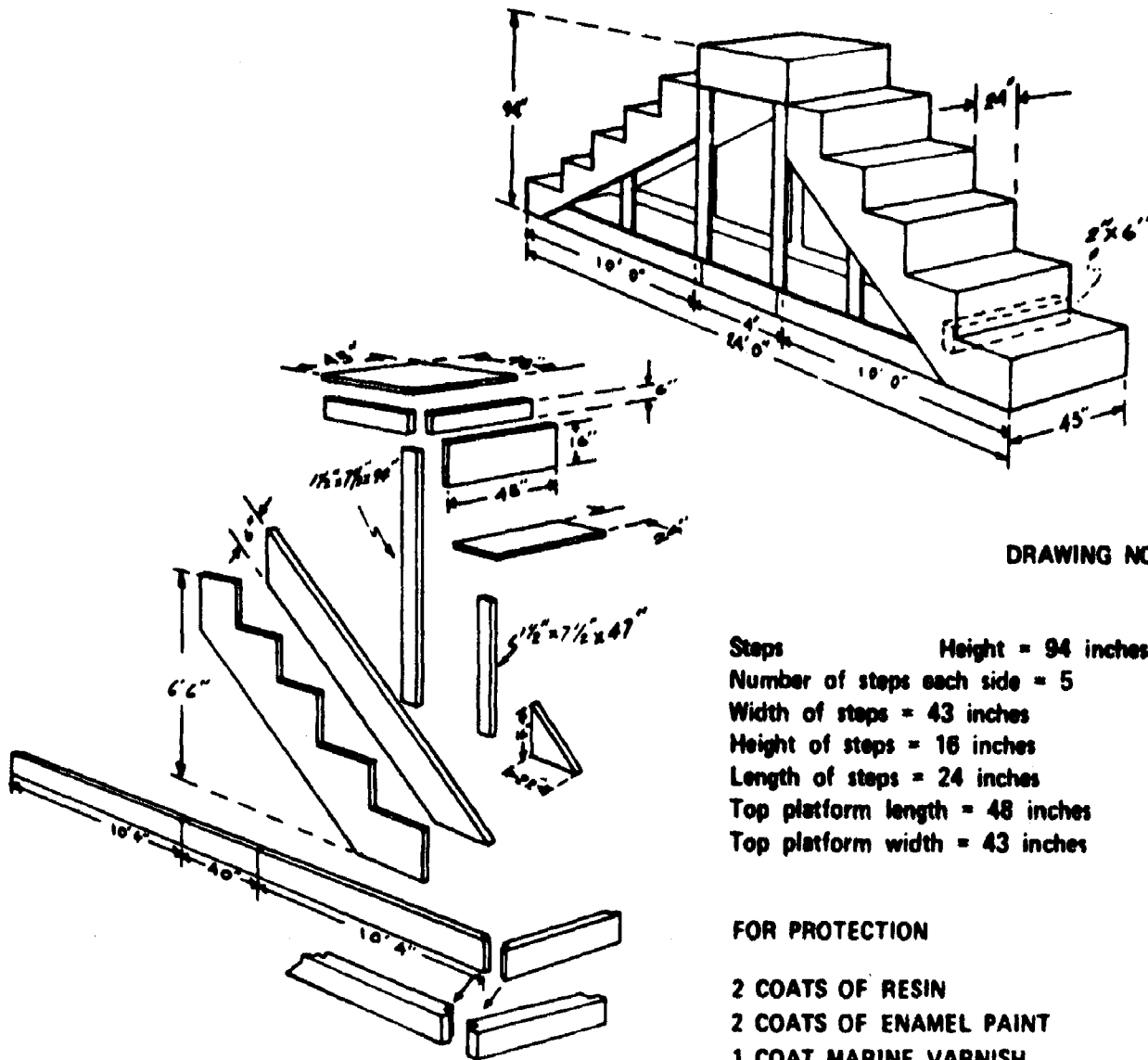
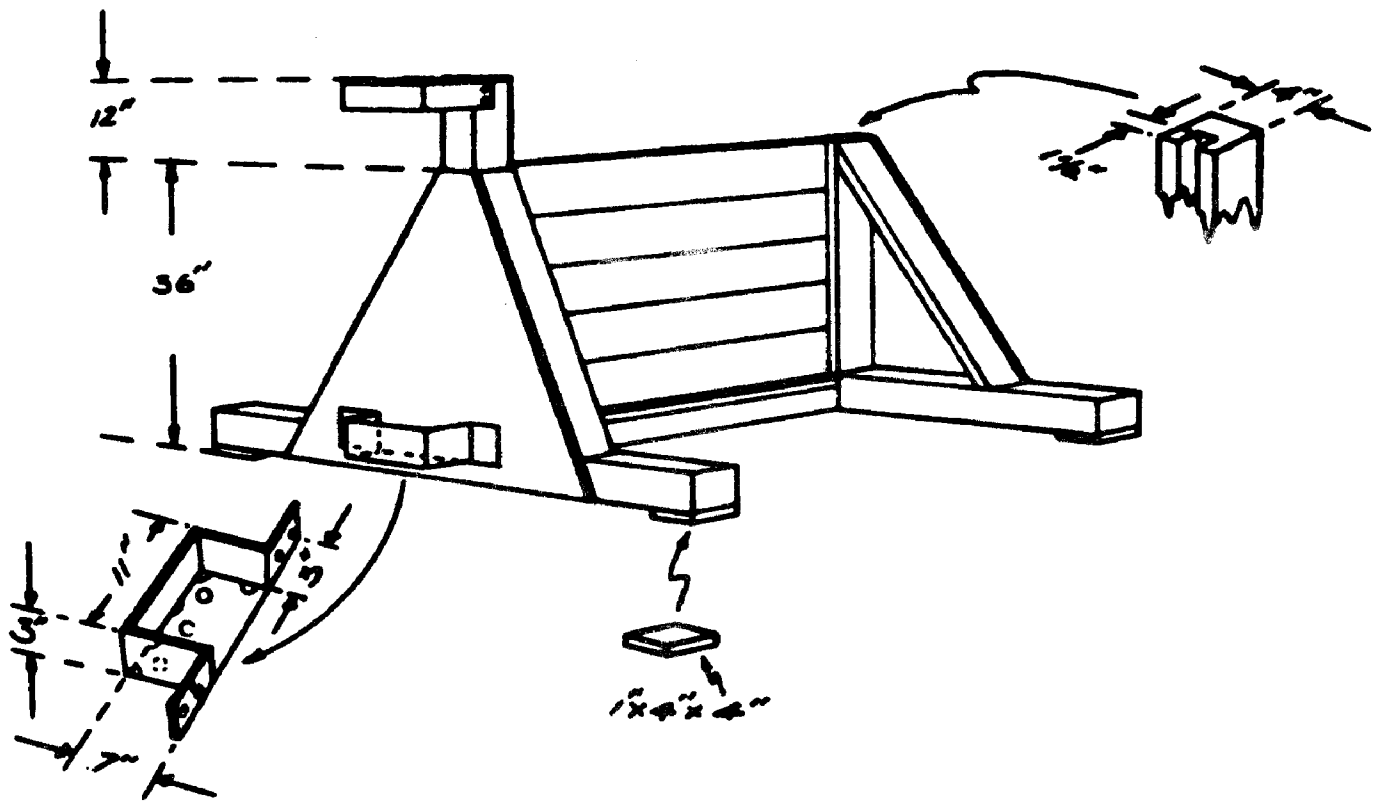

Figure 7-10. Specifications for steps



Jumps 1, 2, and 3
 Height at maximum raised level for dog to negotiate = 36 inches
 Number of removable boards = 6
 Length of 6 boards, each = 51 inches
 Height of 6 boards, each = 6 inches
 Thickness of each board = 1 inch **DRAWING NOT SCALED**

FOR PROTECTION

2 COATS OF RESIN
2 COATS OF ENAMEL PAINT
1 COAT MARINE VARNISH

Figure 7-11. Specifications for jumps

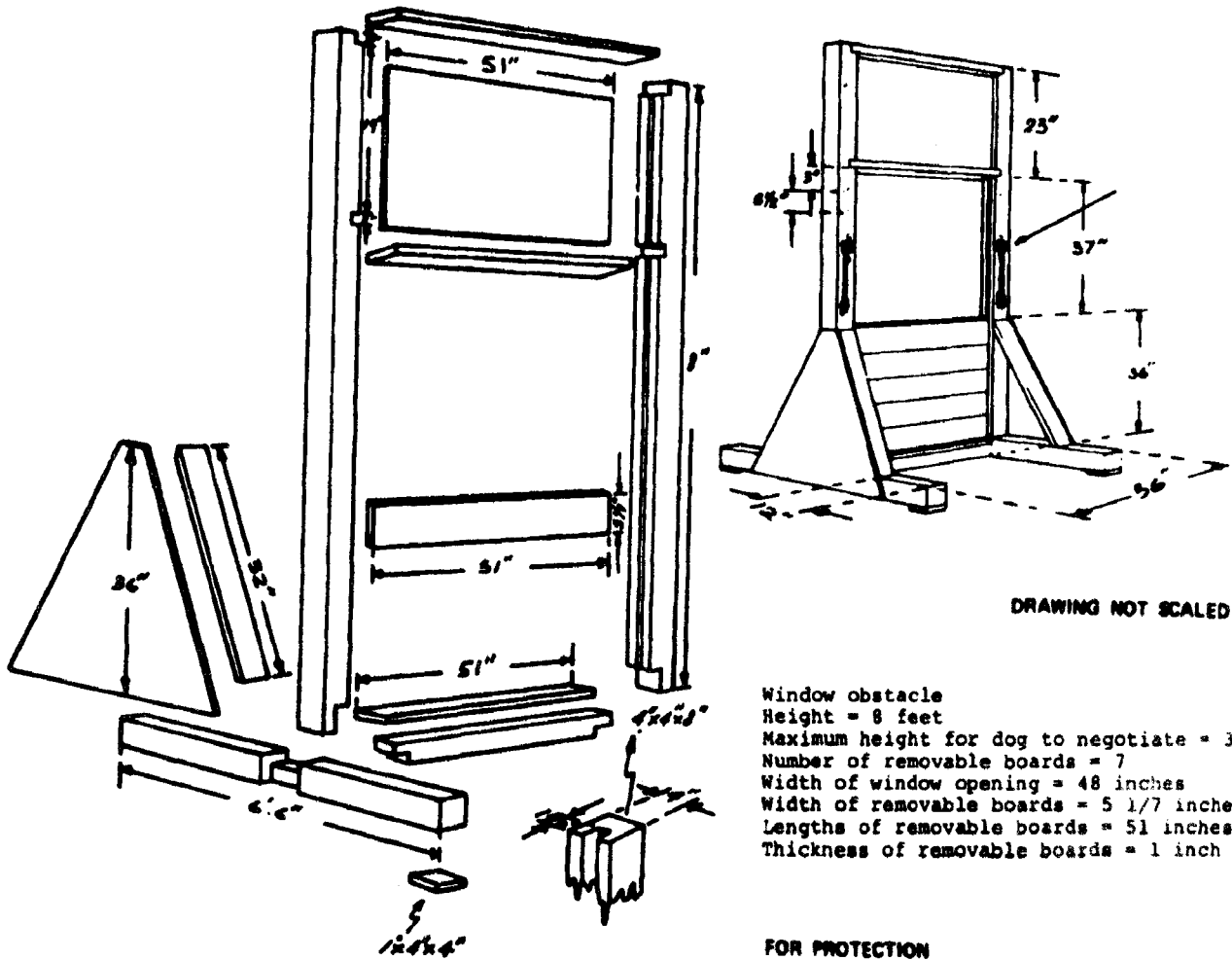

DRAWING NOT SCALED

- Window obstacle
- Height = 8 feet
- Maximum height for dog to negotiate = 36 inches
- Number of removable boards = 7
- Width of window opening = 48 inches
- Width of removable boards = 5 1/7 inches
- Lengths of removable boards = 51 inches
- Thickness of removable boards = 1 inch

FOR PROTECTION

- 2 COATS OF RESIN
- 2 COATS OF ENAMEL PAINT
- 1 COAT MARINE VARNISH

Figure 7-12. Specifications for window obstacle

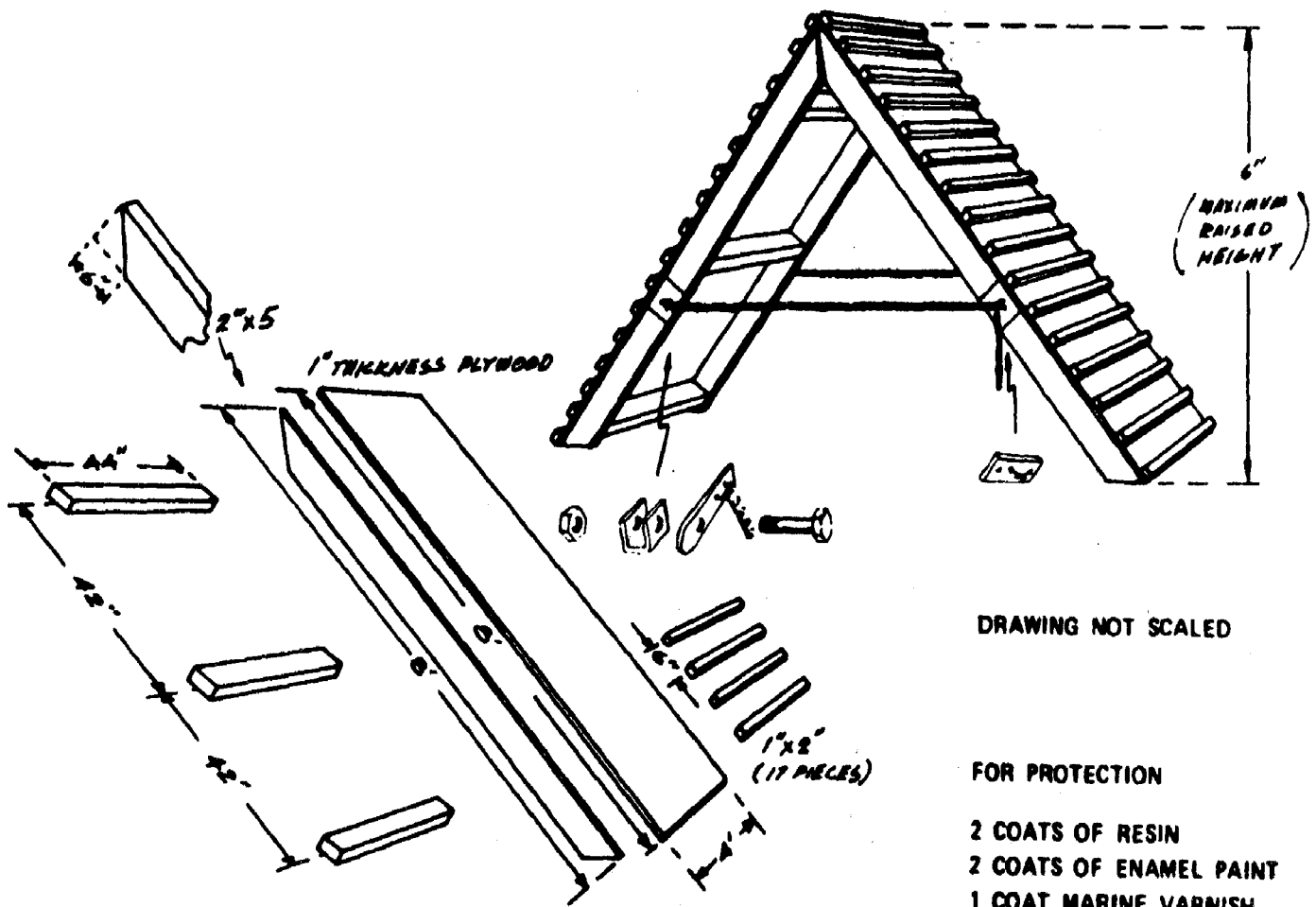

"A" frame, length 16 feet, 8 feet on each side
 Maximum raised height = 6 feet
 Adjustable from the horizontal position to the maximum allowable of 6 feet
 Width = 4 feet
 Added 1½-inch-wide boards every 4½ inches to insure safe footing

Figure 7-13. Specifications for "A" frame

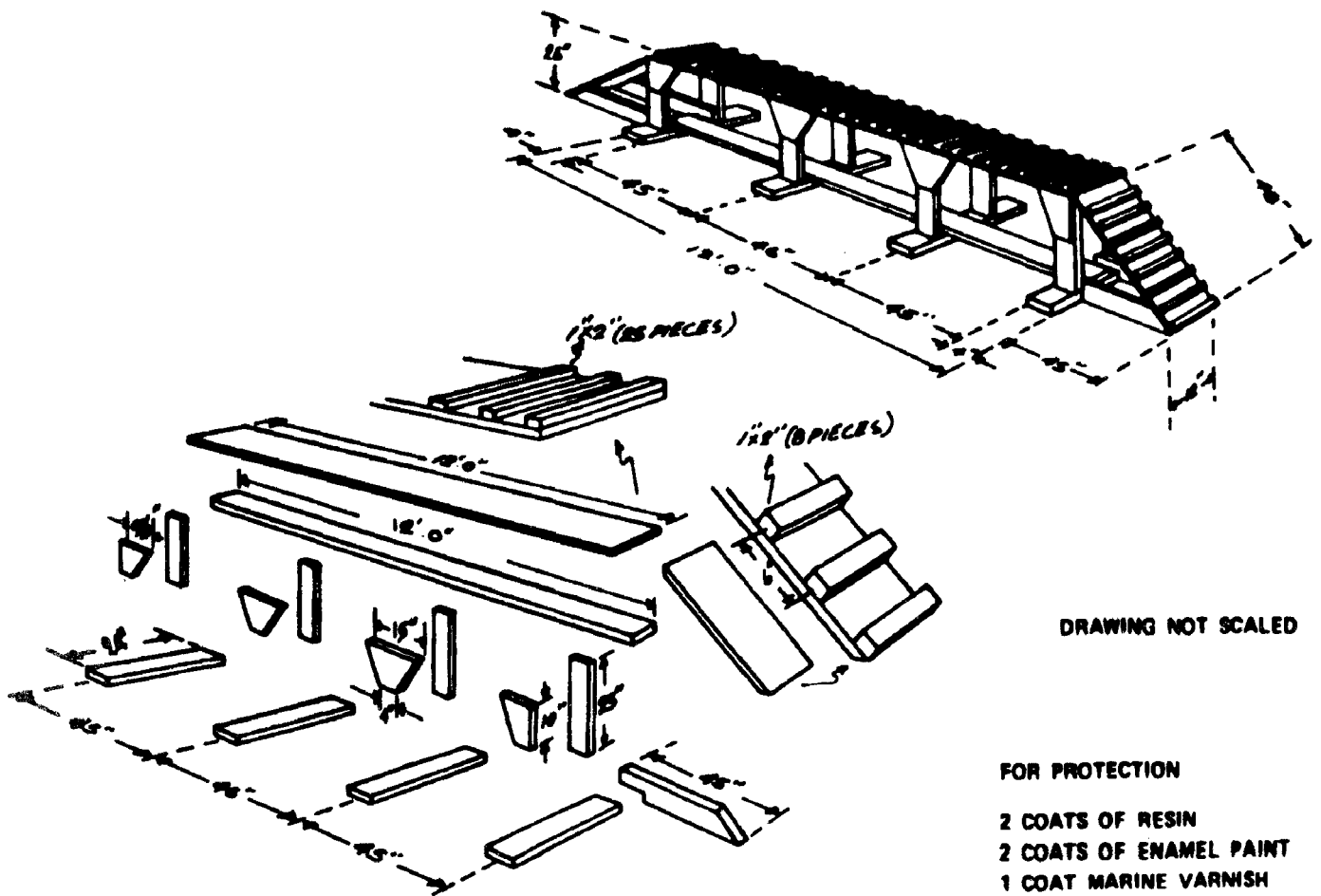

Dogwalk
 Height = 28 inches
 Length = 224 inches
 Width = 11 feet
 2-inch-wide boards every 4 inches to insure safe footing
 45° incline ramp on each end of dogwalk, 11 inches wide, 49 inches long. (To be included in total 224-inch overall length measurement.)

Figure 7-14. Specifications for dogwalk

Chapter 8 Authorized Equipment

8-1. General

The various items of equipment authorized for MWDs and kennel facilities are listed in Common Tables of Allowance (CTA) 50-900 and CTA 50-970. Commanders, kennelmasters, and handlers must make sure all necessary equipment is available and kept in good condition.

8-2. Initial issue equipment

The following items of equipment are used by each handler and are issued when the handler enters initial patrol dog training. Replacement of these items is the responsibility of the unit or installation to which the dog and handler are assigned.

a. *Choke chain.* The choke chain is the basic collar used for all MWDs. Usually the choke chain is left on the dog. Choke chains are available in several sizes and the handler is responsible to make sure the correct size is used.

b. *Leather collar.* The leather collar is used when a dog is secured to a stationary object. Some older patrol dogs and detector dogs were trained to work only when wearing the leather collar. Current training procedures have eliminated the need to use the leather collar as a work cue, but some dogs may work more effectively when the leather collar is used as a work cue.

c. *Kennel chain.* The 6-foot kennel chain is used with the leather collar when securing the dog to a stationary object on a temporary basis. The kennel chain is never tied around the dog's neck or snapped to the choke chain.

d. *Muzzle.* The muzzle is used only as a safety device when it is necessary to prevent the dog from biting. The muzzle is most commonly used when the dog is receiving veterinary treatment or field first aid treatment. The muzzle is usually not used during training because it is distracting to the dog.

e. *Leash.* Two types of leashes are available for use: the 60-inch leather leash and the 360-inch cotton web training leash. Only the 60-inch leather leash is initial issue. The 360-inch cotton web leash is used during advanced obedience training, some phases of attack training, and when the dog is used for tracking.

f. *Equipment holder.* The equipment holder is used to secure items of equipment so the handler's hands remain free.

g. *Comb and brush.* The dogs should be brushed often to remove loose hair, spread natural oils, remove dirt, and to prevent their hair from matting. The comb should be used only when necessary because excessive combing removes the dogs undercoat and may scratch or cut the skin.

h. *Reward ball.* Detector dogs are usually trained to detect narcotics or explosives using a rubber ball as a reward. This ball is a special 2 1/2-inch hard rubber ball that can be purchased from dog equipment suppliers.

8-3. Organizational equipment

The following items of equipment are not issued to the handler when entering training, but must be available so that he or she can properly care for and train the dog.

a. *360-inch cotton web training leash.* Use of the leash is explained in paragraph 8-2e.

b. *Feeding pan.* The feeding pan is stainless steel and has a 3-quart capacity. This size is enough to hold the dog's daily ration and allow the dog room to eat.

c. *Water bucket.* The water bucket is galvanized steel or galvanized metal and holds at least 3 1/2-gallons of water. Each dog has a water bucket. The bucket is cleaned and refilled daily with fresh potable water. In cold weather, water in the bucket must be located in an area where it will not freeze. For small breed dogs, a standard feed pan may be used for a water container.

d. *Leather harness (NSN 3770-00-240-6620).* The only time the patrol dog wears the leather harness is while tracking. The tracking harness is specially designed to ground scent. A scouting harness is specially designed to allow the dog to scout with its head up. The harness enables the handler to control the dog's ranging distance, but still allows the dog to breathe normally. When the harness is worn, the choke chain is removed. Although some dogs may scout or track without the harness, the harness serves as a useful cue to the dog that the mission to be performed is scouting or training. The dog's efficiency is greater in a harness.

e. *Arm protector.* The arm protector is used by an agitator or decoy when training patrol dogs in controlled aggression. This sleeve is used instead of the attack suit sleeve because patrol dogs trained on the larger, more bulky attack suit sleeve tend to have a weaker, more inconsistent bite. The smaller sleeve is easier for the dog to bite and dogs will then learn to more readily bite the arm rather than some other portion of the body. The arm protector should always be wrapped with heavy cloth or burlap to serve as added padding against bites and bruises. Also, the cloth allows a greater degree of protection against injury to the dog's teeth and gums. Target cloth, NSN 8305-00-285-2152, is very suitable for the outer wrap and is available through supply channels.

f. *Attack suit.* The attack suit is used for patrol. The attack suit consists of the leather protective pants or overalls (which are made similar to overalls) and the leather protective vest. A variety of protective gauntlets, cuffs, and sleeves are available for use with the attack suit to protect the arms and hands.

g. *Shipping crate.* The shipping crate is aluminum and is designed for transporting MWDs over a long distance. It may be used for a temporary kennel (NSN: 8115-00-803-3172).

8-4. CTA 50-900

Items of dog training equipment are authorized in CTA 50-900. They are listed in table 8-1.

8-5. CTA 50-970

Items of MWD and kennel facility equipment are authorized in CTA 50-970. (See table 8-2).

8-6. Care of equipment

a. Leather equipment should be wiped with a damp cloth whenever it becomes muddy or dirty. Leather should be thoroughly cleaned with saddle soap weekly. All leather equipment in storage must be inspected periodically and in ready working condition.

- b. Rust will be removed from metal equipment and parts with a fine grade of steel wool. After cleaning, a very light coat of oil will be applied to the metal.
- c. Web equipment will be kept clean by washing as needed.

8-7. Support vehicles

a. Each unit, installation, and activity with assigned MWD teams should assign enough support vehicles so that mission and kennel support activities can be properly maintained. Some variation of the types of vehicles may be necessary to be sure that the vehicles used are appropriate for the purpose and offer the most functional configuration. Regardless of the type of vehicles used, some modification will usually be necessary to maximize the mission effectiveness of the dog, to provide the dog a comfortable, supportive, and protective area, and to prevent unnecessary damage to the vehicle interior. Paragraph 2-4c describes the platform which must be installed in a vehicle when using patrol dogs in mobile patrols.

b. Support vehicles assigned to units with EDDs must be equipped and maintained so that the vehicles meet the safety requirements to transport explosives. Vehicles that do not meet the explosives safety requirements will not be used to transport explosives.

c. All vehicles used to transport MWDs must be equipped with removable warning signs with the wording "CAUTION-MILITARY WORKING DOGS." Signs are placed on the sides of the vehicle when it is used to transport dogs.

8-8. Training aids weight scale

One trip balance laboratory scale, NSN 6670-00-401-7195, is authorized by CTA 8-100 for each MP unit with authorized narcotics/contraband detector dogs, and is used for weighing narcotics/contraband training aids as explained in chapter 4.

8-9. Approved locking devices

Only approved locking devices are authorized for use where locks and locking hardware are required. Approved locking devices are:

a. Padlocks, military specification MIL-P 43607(GL) (high-security padlock) with the NSN 5340-00-799-8016 (open shackle with clevis and chain), and NSN 5340-00-799-8248 (shrouded shackle with clevis and chain).

b. Padlocks, military specification MIL-P-17802C body with the NSN 5340-00-158-3807 (with chain), and NSN 5340-00-158-3805 (without chain).

c. Pin tumbler mortise locks with dead bolt that conform to the following minimum standards:

- (1) Dead bolt throw of at least one inch.
- (2) Double cylinder design.
- (3) Five pin tumblers of which two will be mushroom or spool-type drive pin design.
- (4) Have 10,000 or more key changes.
- (5) Is not master keyed.
- (6) Bolt is not visible when in the locked position.

d. High-security hasps described in MIL-H-43905A for use with the high-security padlock. The high-security hasps are currently manufactured in nine styles, with the first six styles being the styles to be used.

e. Hasps and staples for secondary locks which are heavy pattern steel, securely fastened to the structure with smooth headed bolts, rivets, or welding to prevent removal.

**Table 8-1
Dog training equipment authorized in CTA 50-900**

LIN	Item	Basis of issue
T72252	Sleeve, dog attack trainer's: Arm chrome leather outer covering. NSN 8415-01-122-0684	1 per 5 MWD
	Sleeve, dog attack trainer's: Arm sagless jute cloth outer covering. NSN 8415-01-122-0681	1 per 5 MWD
	Sleeve, dog attack trainer's: Arm 840 denier nylon outer covering. NSN 8415-01-122-0683	1 per 5 MWD
	Sleeve, dog attack trainer's: Arm, one-ply animal jute outer covering, 29 inches long. NSN 8415-01-122-0678	1 per 5 MWD
	Sleeve, dog attack trainer's: Arm, one-ply animal jute outer covering, 24 inches long. NSN 8415-01-122-0682	1 per 5 MWD
	Sleeve, dog attack trainer's: Forearm 9-11 ounce aluminum. NSN 8415-01-122-0685	1 per 5 MWD
	Sleeve, dog attack trainer's: Arm 1/4' neoprene rubber. NSN 8415-01-122-0679	1 per 5 MWD
	Sleeve, dog attack trainer's: Upper Arm 2-ply split leather. NSN 8415-01-122-0680.	1 per 5 MWD
	Sleeve, dog attack, trainer's: Hand protective, German jute. NSN 8415-01-122-0674	1 per 5 MWD
F53543	Cuff, dog attack trainer's. NSN 8415-01-122-0686	As required
E43371	Vest, dog attack trainer's. NSN 8415-01-122-0675	1 per 5 MWD
X35399	Overall, dog attack trainer's. NSN 8415-01-122-0676	1 per 5 MWD

Table 8-2
Military working dog and kennel facility equipment authorized in CTA 50-970

NSN	Item	Basis of issue
3770-00-163-9542	Blanket, dog coat style OD, large	1 per dog
	OR	
3770-00-163-9543	Blanket, dog coat style OD, Med	1 per dog
	OR	
3770-00-163-9544	Blanket, dog coat style OD, Small	1 per dog
3770-00-555-9959	Brush, animal grooming	2 per dog
3770-00-162-6207	Chain, dog kennel steel, 72 inches long	2 per dog
3770-00-951-6418	Collar, dog leather with D-Ring and buckle, 18 inches by 2 inches wide.	2 per dog
3770-00-255-6191	Collar, dog steel chain choke 24 inches, 22 inches or 20 inches	2 per dog
3770-00-163-2606	Comb, dog	1 per dog
3770-00-171-1257	Holder, dog leash leather belt type with triple snap.	1 per handler
3770-00-171-1258	Leash, dog with swivel and snap leather lead type.	2 per dog
3770-00-171-1256	Leash, dog with swivel and snap cotten webbing OD, 360 inches long 5/8 inch wide.	1 per dog
3770-00-170-1495	Muzzle, dog leather russet	2 per dog
3770-00-105-2717	Muzzle, dog attack bite proof	1 per dog
7240-00-160-0455	Pail, metal steel galvanized	2 per dog
3770-00-951-3230	Pan, dog feeding aluminum 3 quart capacity.	2 per dog
3770-00-025-7914	Leash, dog nylon	1 per dog in hot/wet climate
3770-00-026-2409	Holder, dog leash nylon	1 per dog in hot/wet climate

Chapter 9 Inspections

Section I Operational Inspection Guidelines

9-1. General

a. This chapter provides the commander with inspection guidelines. The reading of this chapter alone will not provide a commander or any other inspector with sufficient knowledge to perform a competent inspection. Before beginning an inspection, the commander needs to be thoroughly familiar with the policy of AR 190-12, this pamphlet, FM 19-35, and other relevant publications. This chapter provides guidance regarding the scope of an inspection and directs the commander towards inspecting those activities which need the greatest attention. A commander is not limited by this guidance and may inspect any aspects of the unit MWD program to ensure that his or her MWD teams are technically, operationally, and administratively proficient.

b. AR 190-12 requires that the unit commander conduct a monthly inspection of handlers, dogs, training, team utilization, team proficiency, equipment, and kennel facilities. A detailed, comprehensive inspection is necessary because of the complexity of a unit MWD program. Therefore, the specifications of the monthly inspections may be varied, provided that all aspects of the unit MWD program are inspected at least quarterly. A written record of inspections is required, and each monthly inspection should ensure that corrective action has been taken on any deficiencies noted during previous inspections. Most inspections should be "working inspections" so interference with operational commitments can be minimized. Both announced and unannounced inspections should be made.

Section II Facilities

9-2. Kennels

Proper construction, maintenance, and sanitation are essential for the dog's health. Improper and faulty construction may not be apparent until after the facility has been occupied, but should be corrected as soon as possible to protect the dogs and handlers from hazardous conditions. The commander should check to ensure the following:

a. Kennel runs:

- (1) Are clean and free of animal wastes.
- (2) Have concrete surfaces smoothly finished and in good repair.
- (3) Have concrete block walls surfaced with smooth concrete or wainscot.
- (4) Have metal walls free of rust and dirt.

b. Houses or pallets are clean and in good repair. Look closely at inside corners and underneath the pallet or house

since these are common breeding places for insects and parasites. Houses or pallets that have been chewed on may indicate a bored dog. Check the dog's training record to ensure that it is being used and trained properly.

- c.* Floor slope allows for natural drainage of liquid wastes from runs and houses.
- d.* Water buckets are clean and filled with an adequate amount of water. Also, ensure that the drinking water supply is adequate.
- e.* Fencing and lighting are adequate and proper warning signs are posted. Check for loose fencing, holes in the fence or ground under a fence, or sharp objects which may cause injury to a dog. All electrical cords should be out of reach of the dogs.
- f.* Drainage gutter is free of animal wastes, hair, and other foreign matter. Also, ensure that stools are removed, not washed down the drain.
- g.* The plumbing system is adequate to handle all drainage throughout the kennel facility (that is, no sewage back-up).
- h.* Kennel area (inside and out) is policed and free of dog stools.
- i.* Fire fighting equipment is available and serviceable.
- j.* The kennel area is free of standing water that could allow insect breeding.

9-3. Kennel support building

The commander should check to ensure the following:

- a.* The food preparation area is clean and all equipment is in good condition.
- b.* The food preparation area and the food storage area is neat and orderly. Food must be stored in rodent proof containers. Storage areas should be checked for signs of rodents or insects.
- c.* Feed pans are clean and do not feel greasy.
- d.* Hot water supply is adequate for food preparation and cleaning.

9-4. Training and exercise areas

The commander should check to ensure the following:

- a.* Training and exercise areas:
 - (1) Are policed.
 - (2) Are free of dog stools.
 - (3) Have vegetation trimmed.
 - (4) Are free of standing water.
 - (5) Are free of rocks, glass, and other materials that could injure the dogs.
- b.* Fencing is in good repair with no loose wires that could cause injuries.
- c.* Holes are filled promptly, seeded, and packed.
- d.* Gate locks work properly and gates close automatically and securely.
- e.* The obedience course is in good condition with:
 - (1) All obstacles present and properly constructed.
 - (2) No loose boards or nails.
 - (3) All obstacles properly painted with nonskid paint or other nonskid materials on surfaces traveled by the dog.
 - (4) Wood surfaces reasonably smooth and free of splinters.

Section III

Equipment

9-5. Leather and metal

The commander should check to ensure the following:

- a.* Leather is treated with a light coat of neat's-foot oil (saddle leather) or saddle soap (latigo leather).
- b.* All metal chains and snaps are clean and rust free.
- c.* Snaps have adequate spring tension to keep the snap in the closed position and work freely.
- d.* Equipment is stored in a clean, dry place.
- e.* Shovels, rakes, mowers, water hoses, and other equipment are clean, in good repair, and neatly stored.

9-6. Supplies

The commander should check to ensure the following:

- a.* A 30-day supply of dog food for each dog is available.
- b.* All food is stored in dry, rodent-proof containers.
- c.* Food is rotated to use the oldest first to avoid spoilage.

d. Dog food is MSD (see para 6–24), or food specifically procured by direction of the veterinarian for special dietary requirements.

e. First aid kits, disinfectant, and cleaning equipment are readily available, of the correct type, and in sufficient quantity.

f. Medicines, ointments, and other prescriptions are being used as prescribed.

Section IV

Appearance and Condition of Dogs

9–7. Appearance

The commander should check to ensure the following:

a. The dogs appear healthy and properly groomed.

b. Coats are shiny and free of mud, dirt, and burrs.

c. Eyes are clear. Discharge from the eyes may indicate an illness and the veterinarian should be aware if there is a problem.

9–8. Physical condition

The dog's physical condition may be evaluated by observing the dog negotiate the obedience course (unless the dog has been exempted by the veterinarian). The dog's alertness and aggressiveness in training and while performing operational duties are also keys to its physical condition.

Section V

9–9. Veterinary inspections

The provost marshal should check to ensure that periodic veterinary inspections are being conducted. Frequency should depend on the nature and severity of any health or sanitation problems; however, at a minimum, quarterly inspections are to be made. Any deficiencies noted by the veterinarian during his or her inspection should be corrected as quickly as possible. The commander's inspection should ensure that all corrective action taken is both appropriate and adequate to avoid any continuing health or sanitation problem.

9–10. Veterinary instructions

a. The veterinarian may provide instructions to handlers and the kennelmaster regarding the:

(1) Care of the dogs.

(2) Feeding of the dogs.

(3) Grooming of the dogs.

(4) Medication for the dogs.

(5) Physical conditioning of the dogs.

(6) Materials for sanitation and for extermination of pests.

b. The provost marshal's inspection should verify that:

(1) All materials, medications, and procedures prescribed by the veterinarian are present or being applied.

(2) Sanitation instructions applicable to the kennels, the food preparation area, feed pans, and water buckets are followed.

(3) Feeding records comply with instructions.

(4) Medications are administered in specific quantities and according to the prescribed schedule.

9–11. Veterinary support

The provost marshal's inspection should verify that the veterinarian is providing adequate guidance to each of the handlers regarding the health, care, and feeding of their dogs. The completeness of first aid kits, the availability of medical supplies, and the ease of access to veterinary assistance are all indicators as to whether guidance is adequate. Although all units may not have direct or immediate access to a veterinarian, this assistance should be reasonably available. (Interpretation of reasonable may depend on the distance to the nearest veterinarian.) Further, the veterinarian is responsible for providing some medical training (at least first aid) to handlers. Training should occur with reasonable regularity so that handlers are able to properly care for a dog that is sick or injured until the veterinarian can respond.

Section VI

Use and Training

9–12. Use

MWD team assets are of little value if they are not used. Qualified MP handlers can perform most MP missions better

when employed as a team with his or her assigned dog. Proper care requires good planning, proper scheduling, and coordination. The types of duties performed should be varied so that the team's proficiency is maintained in all areas, and to keep the dog from losing its alertness and aggressiveness. Planning, scheduling, and use are to be documented on training and utilization records. The handler should be knowledgeable about use of force principles and show reasonable ability to apply this knowledge in real situations. An MWD team's performance while on duty should be observed to ensure that the handler is able to control the dog, and that the dog responds appropriately in real situations.

9-13. Training

Training records should be closely examined to make sure they are kept current and that proficiency training is conducted with sufficient regularity to maintain the MWD team's proficiency. A minimum of 4 hours of patrol dog training is required each week for patrol dogs and a minimum of 4 hours of detection training is required for detector dogs each week. To be effective, training must be planned, it must be scheduled, and records should be present to verify appropriate planning and scheduling. Weaknesses which are noted during use and training should be specifically identified, and corrective training should be conducted to avoid their repetition. A lack of corrective training indicates an exceptional dog or a handler and kennelmaster who are not honestly maintaining their training records. Any MWD team that is not performing as well as the records indicate should be required to undergo appropriate proficiency evaluation or validation tests (chap 3).

9-14. Handler knowledge

Handlers should be able to demonstrate their knowledge of dog handling and knowledge appropriate to their MP skill level. Handler knowledge includes handling, acting as a decoy, controlled aggression, obedience, scouting or patrolling, tracking (if appropriate), detection, and full understanding how an MWD team is operationally employed so that the team's performance always supports the accomplishment of the MP mission.

9-15. Demonstration of proficiency

All MWD teams should be required to demonstrate their proficiency, in one or more of the skills appropriate for the type of dog, during some phase of the inspection. A spot check of proficiency verifies that the records are a reasonably accurate reflection of reality. Proficiency standards are provided in chapter 3.

Section VII

Training Aids Accountability

9-16. Narcotics training aids

Detailed instructions are provided in chapter 4 for the control, storage, security, and accountability of controlled substance training aids. The commander should spot check security and accountability records to be sure that records are being properly maintained, that monthly inventories and audits are being conducted as required, and that records completely account for a training aid disposal. At least some training aids should be weighed to verify that they are all still present. Disposition records should be checked to ensure that training aids destroyed were properly destroyed and witnessed. Any other disposition should also be properly documented.

9-17. Explosives training aids

Detailed instructions are provided in chapter 5 for the safe handling, transportation, control, security, storage, and accountability of explosives training aids. Inspections should verify that handlers who use explosives training aids are reasonably knowledgeable about the characteristics of each of the explosives and the requirements discussed in chapter 5. Vehicles used to transport explosives should have a current safety inspection, and vehicles should be checked to determine if there are any apparent safety hazards that may have arisen since the last safety inspection. Training should be observed to be sure that handlers maintain safe distances and properly handle explosives. No training aid should be "cut" to a size smaller than that required (for example, one stick of dynamite). Any personnel involved in training with explosives training aids must have received all appropriate explosives safety training, and this training must be documented. The handler may be questioned to confirm the extent of his or her knowledge.

Section VIII

Records

9-18. Administrative and medical records

The information on the front of the DD Form 1834 (Military Working Dog Service Record) is filled in at the 341st Military Working Dog Training Squadron when the animal is accepted into military service. The kennelmaster is responsible for the information on the back. This includes the handler's name, grade, social security number, date the dog was assigned to the handler, organization and installation. Verify that the information is correct. Medical records may be kept at the kennels or at the veterinarian's office at the discretion of the attending military veterinarian. Only veterinary personnel are allowed to make entries in the medical record. Administrative and medical records are sent to

the gaining installation when the MWD team or the dog is transferred. When a dog dies or undergoes euthanasia, administrative and medical records are sent to the 341st Military Working Dog Training Squadron. The only records kept on hand in the kennel are for dogs assigned to the unit or installation.

9-19. DA Form 2807-R

Training and utilization time should be entered daily in the appropriate blocks along with appropriate ratings. If a dog is rated as continuously satisfactory, conduct a proficiency evaluation (full or partial) to determine if these ratings are done according to proficiency standards. Determine what actions were or are being taken to correct unsatisfactory proficiency. The deficiency and corrective action may be noted on the back of the form. Entries may be typed or handwritten. This is a working document, so there can be handler or kennelmaster notations. The record should still be reasonably neat so that it can be determined how and when the dog is being trained and utilized. The feeding and weight section are maintained daily to record the type and quantity of food consumed by the dog. Any feeding problems should be discussed with the veterinarian. The dog's weight is entered semi-monthly, and reflects the dog's weight at approximately the same times each month. A significant change in weight should be reported to the veterinarian by the handler.

9-20. DA Form 3992-R

a. Detector dog training must be properly documented. Each line item must indicate the number of training aids planted, the number of training aids found, and the search time.

b. Actual searches are recorded on the back of DA Form 3992-R. All appropriate entries should be completed for each case, to include verification by field test, lab test, or EOD of the type of substance detected.

c. The monthly computation of proficiency is based on training aid plants and finds only. Be sure that sufficient training is being conducted for the computation to be statistically valid (50 or more trials per month). Spot check the computation to be sure that the rating is accurate, especially for detector dogs at or near the proficiency standard. Determine what actions are being taken to retrain detector dogs that have fallen below the proficiency standard. Looking at several month's proficiency ratings can also help identify trends so that proficiency training can be intensified when a dog appears to be on a steady downward trend.

9-21. Controlled substances training aids accountability folder

Check each accountability folder to make sure that a clear audit trail exists, and that all controlled substances are accounted for. Each folder should have a DEA Form 222 (or DA Form 4137) showing the type and amount of each controlled substance received, a DA Form 4608-R showing how the procurement was broken down into individual training aids, and DEA Form 41 (or other appropriate documentation) verifying proper disposition of any training aids no longer being used. Verify the most recent inventory of training aids by comparing control numbers and amounts to those recorded on DA Form 4608-R. Check DA Form 4608-R to ensure training aids are signed out and returned on the same day. Any deviations from the same day requirement must be authorized in writing. Training aids are to be signed out and signed back in when being turned in. Weight deviations must be explained in writing or investigated, as appropriate.

Appendix A References

Section I Required Publications

AR 190-11

Physical Security of Arms, Ammunition and Explosives. (Cited in paras 5-6, 5-7b, and 7-40b.)

AR 190-12

Military Police Working Dogs. (Cited in paras 1-1, 1-7, 1-14, 1-15, 1-18a, 1-19a, 1-22, 2-2a, 2-31c, 2-34b, 2-35a, 2-35e, 2-38, 2-39f, 3-35a, 5-7a, 7-29, 9-1a, and 9-1b.)

AR 190-45

1-13, Military Police Law Enforcement Reporting. (Cited in para 2-44.)

AR 190-51

Security of Army Property at Unit and Installation Level. (Cited in paras 4-6a, 7-37, 7-40b, B-5d, and B-8d.)

AR 310-49

The Army Authorization and Utilization Policies and Criteria, and Common Tables of Allowances. (Cited in para 1-14.)

AFR 70-12/AR 700-81/NAVINST 10570.1/MCO 20570.1

DoD Dog Program. (Cited in para 1-1.)

Section II Related Publications

AR 40-1

Composition, Mission, and Functions of the Army Medical Department

AR 40-3

Medical, Dental, and Veterinary Care

AR 40-656

Veterinary Surveillance Inspection of Subsistence

AR 40-905

Veterinary Health Services

AR 55-355

Defense Traffic Management Regulation

AR 75-15

Responsibilities and Procedures for Explosive Ordnance Disposal

AR 190-14

Carrying of Firearms and Use of Force for Law Enforcement and Security Duties

AR 190-22

Searches, Seizures, and Disposition of Property

AR 190-40

Serious Incident Report

AR 210-10

Administration

AR 385-30

Safety Color Code Markings and Signs

AR 385-64

Ammunition and Explosives Safety Standards

AR 600-200

Army Command Policy

AR 611-201

Enlisted Career Management Fields and Military Occupational Specialties

AR 710-2

Supply Policy Below the Wholesale Level

AR 740-26

Physical Inventory Control

DA Pam 710-2-1

Using Unit Supply System (Manual Procedures)

FM 5-25

Explosives and Demolitions

FM 19-10

The Military Police Law and Order Operations

FM 19-15

Civil Disturbances

FM 19-30

Physical Security

FM 19-35

Military Police Working Dogs

DOD 4270.1-M

Construction Criteria Manual

DODD 3025.12

Employment of Military Resources in the Event of Civil Disturbances

DODD 5200.31

Single Manager for DoD Working Dog Program

DODD 6015.5

Joint Use of Military Health and Medical Facilities and Services

TC 19-5

Bomb Threats

TM 5-302

Army Facilities Components System: Design

TM 5-303

Army Facilities Components System – Logistic Data and Bills of Materiel

TM 5-809-1

Load Assumption for Buildings

TM 5-809-2

Concrete Structural Design for Buildings

TM 5-809-3

Masonry Structural Design for Buildings

TM 5-809-4

Steel and Aluminum Structural Design for Buildings

TM 5-809-5

Wood Structural Design for Buildings

TM 5-809-6

Structural Design: Structures Other than Buildings

TM 5-809-8

Metal Roofing and Sliding

TM 5-809-9

Structural Design for Thin-Shell Roof Construction

TM 5-809-10

Seismic Design for Buildings

TM 5-809-11

Design Criteria for Facilities in Areas Subject to Typhoons and Hurricanes

TM 9-1300-206

Ammunition and Explosives Standards

Section III

Prescribed Forms

This section contains no entries.

Section IV

Referenced Forms

Exact duplicates of any DA or DD forms generated by the automated Military Police Management Information System may be used in place of the official printed version of the form.

Forms that have been designated “approved for electronic generation (EG)” must replicate exactly the content (wording), format (layout), and sequence (arrangement) of the official printed form. The form number of the electronically generated form will be shown as -R-E and the date will be the same as the date of the current edition of the printed form.

DA Form 581

Request for Issue and Turn-in of Ammunition

DA Form 2028

Recommended Changes to Publications and Blank Forms

DA Form 2807-R (approved for EG)

Military Working Dog Training and Utilization Record

DA Form 3655

Crime Lab Examination

DA Form 3975

Military Police Report

DA Form 3992–R (approved for EG)

Narcotics or Explosives Detector Dog Training and Utilization Record

DA Form 4137

Evidence/Property Custody Document

DA Form 4607–R (approved for EG)

Controlled Substance Training Aid Utilization Record

DA Form 4608–R (approved for EG)

Controlled Substances Accountability Record

DA Form 4610–R

Equipment Changes in MTOE/TDA

DD Form 1834

Military Working Dog Service Record

DEA Form 41

Registrant's Inventory of Drugs Surrendered

DEA Form 106

Report of Theft or Loss of Controlled Substances

DEA Form 222

DEA Official Order Form for Schedule I and II Controlled Substances

DEA Form 223

Controlled Substances Registration Certificate

DEA Form 225

New Application for Registration Under Controlled Substances Act of 1970

DEA Form 225a

Renewal Application for Registration

SF 702

Security Container Checklist

**Appendix B
Military Working Dog Authorizations**

Section I

General

B–1. Scope

The intent of this appendix is to furnish information that may be useful in planning an MWD program or adding MWD teams to an existing program. The guidelines and yard sticks contained in this appendix are not meant to be “absolutes” for utilizations, training, or maintenance. The following paragraphs do, however, give general guidance and information that should be considered when planning a program. Sections II to V contain performance standards that may be useful in determining the number and type of MWD teams needed. The user of this pamphlet will find all of the following information useful for writing authorization documentation statements, as well as for planning the local MWD program.

B–2. Authorizations

All initial authorizations should be probationary and the following will apply:

- a. Adjustment to be made based on actual utilization data.
- b. Baseline of 30 hours utilization to 4 hours training ratio (with trade-off when appropriate).

- c. Automatic review by respective MACOM after two years.

B-3. Clarification of specific terms

a. Utilization includes all missions (law enforcement, security, and combat support), whether patrolling, detecting drugs or explosives, or other functions (in combination) performed when handler and dog are being employed together as a team.

b. Training includes all training activities to maintain, improve, regain, or develop dog skills such as patrolling, scouting, tracking, detection of persons, detection of drugs or explosives.

c. Maintenance includes all activities related to care, grooming, health, and sanitation of the dog, including medical treatment, recuperative time, sickness, and so forth. Down time for medical reasons is the basis for under utilization or under training.

d. Trade-off is the adjustment between training and utilization necessary to reinforce basic skills or to add new skills. For example, 4 hours per week may be adequate to maintain detector dog proficiency or to train in new skills. Additional training may be justified at times and training hours increased accordingly. This increase in training time should be accompanied by an equivalent reduction in utilization time. However, training hours should not be increased merely as a substitute for lack of utilization.

Section II

Patrol Dog Yardsticks—Peacetime (Law Enforcement/Security)

B-4.

The start point for patrol dog posts (motorized or walking) is as follows:

- a. One per 30 hours of anticipated utilization.
- b. A multiplier of 1.2 (add-on).

B-5.

Factors influencing commitment or justification rationale include:

- a. Installation population (military, civilian, dependent and contractor).
- b. Geographic area served (square miles).
- c. Crime rates or rates of incidents on which presence of dog teams could reasonably be expected to have impact (for example, parking lot larcenies, vandalism, prowlers, house break-ins, schools/commercial activity break-ins, rapes/assaults in areas used as short cuts, IDS responses).
- d. Risk assessment (using AR 190-51) which takes into account:
 - (1) Types of activities and resources on the installation needing protection and the value of same (monetary and intrinsic).
 - (2) The vulnerability of resources.
 - (3) The effect of loss of resources on the Army's wartime capability.
- e. Type of installation access control (for example, closed, open, time-controlled).
- f. Crime rates in the local area.

B-6.

Amending the local TDA/TOE for "peacetime" by adding appropriate dog handler ASIs to the existing structure is the easiest way to start (or add to) a MWD program. A "plus-up" of TDA/TOE is the most difficult way to begin a program and should be the last resort.

Section III

Narcotic Detector Yardsticks in Peacetime (Law Enforcement/Security)

B-7.

Considerations listed in section II still apply, with additional considerations outlined below because of the additional skill of narcotics detection having been added. The start point for additional consideration in justifying narcotic detector dog teams may be any combination of the following:

- a. One authorization per 5000 population supported.
- b. One per 30 hours projected detector utilization.
- c. A multiplier of 1.2 (add-on).

B-8.

Factors for consideration which influence commitment or justification rationale include:

- a. Installation population composition (military, dependent, civilian, median age, and so forth).

b. Crime rates associated with drug abuse; use/possession/sale/trafficking (general measure is one dog team per 100 use/possession cases annually).

c. Level of self-admitted drug use based on survey data.

d. Risk assessment based on AR 190-51 that considers the availability of narcotics (by type), cost, and geographic proximity to drug trafficking centers.

Section IV

Explosives Detector Yardsticks in Peacetime (Law Enforcement/Security)

B-9.

Considerations listed in section II still apply, with additional considerations outlined below because of the additional skill of explosives detection having been added.

a. The start point for additional considerations in justifying explosives detector dog teams is as follows:

(1) One authorization per 10,000 population supported.

(2) A multiplier of 1.2 (add-on).

b. Factors for consideration which influence commitment or justification rationale include:

(1) Number of bomb threats annually.

(2) Number of actual bombs/explosive devices found, and number of actual explosions.

(3) Risk assessment on the following:

(a) Resources needing protection and their value.

(b) The vulnerability of resources.

(c) The impact of the loss of a resource on the Army's wartime capability.

(d) Threat posed (geography, political significance, and so forth).

(e) The probability of overt/covert attack using explosives.

(4) Demographics; for example, Bureau of Alcohol, Tobacco and Firearms (BATF) survey of explosives incidents and the area being identified as a problem area.

(5) Lack of availability or lengthy response time of explosive dogs from other Federal/State agencies in the area (for example, Federal Aviation Administration (FAA), local police, and so forth).

Section V

Patrol, Narcotic Detector, Explosives Detector Yardsticks or Considerations for Wartime Combat Support Role

B-10.

Basic patrol dog utilization in combat is contained in paras 2-26 through 2-30. In addition, consideration must be given to:

a. Operation plans (OPLANs) being supported which may further justify dogs.

b. Size, mission, and type of combat (or combat support, combat service support) organizations(s) being supported.

c. Mission of unit(s) being supported.

B-11.

An additional wartime consideration for patrol dogs dual trained as narcotic detectors would be whether or not OPLANs being supported required deployment to the Middle East or Far East. The narcotics detection capability can be used during deployments to either location. This capability may also prove useful around ports of embarkation/debarkation, especially at sea ports.

B-12.

Additional wartime consideration for patrol dogs dual trained as explosives detectors can be found in any OPLAN being supported. Justification can be found in any of the following areas (not meant to be all inclusive):

a. Terrorism threat.

b. Insurgent threat (that is, during refugee control operations, insurgents may be detected by the hidden ordnance they may be carrying).

c. Key facility security (that is, initial clearance and maintaining that clearance and security on a key bridge on a main supply route (MSR)).

d. Detection of unexploded ordnance.

Glossary

This is the consolidated glossary for the Physical Security Handbook.

Section I

Abbreviations

AA&E

arms, ammunition, and explosives

AC

Active Component

ACSI

Assistant Chief of Staff for Intelligence

ADP

automatic data processing

AE

ammunition and explosives

AFB

Air Force Base

AFH

Army family housing

AFI

annual formal inspection

AFSPA

Air Force Security Police Agency

AG

Adjutant General

AGS

Armed Guard Surveillance

AIF

Army Industrial Funds

AMC

U.S. Army Material Command

AMDF

Army Master Data File

AP

acquisition plan

APSEAG

Army Physical Security Equipment Action Group

AR

Army regulation

ARDEC

U.S. Army Armament Research, Development and Engineering Center

ARNG

Army National Guard

ARSTAF

Army Staff

ASA (IL&E)

Assistant Secretary of the Army (Installations, Logistics, and Environment)

ASA (RDA)

Assistant Secretary of the Army (Research, Development, and Acquisition)

ASI

additional skill identifier

ASI H3

ASI for physical security inspector

ASI P7

ASI for patrol/narcotics or contraband detector dog handler

ASI Z6

ASI for patrol/explosives detector dog handler

ASL

authorized stockage list

ASP

ammunition supply point

AT

antiterrorism

ATC

Air Training Command

ATCOM

U.S. Army Aviation and Troop Command

BASOPS

base operations

BATF

Bureau of Alcohol, Tobacco, and Firearms

BCU

battery coolant unit

BRDEC

Belvoir Research & Development Engineering Center

CB

close boundary

CBT/T

combatting terrorism

CCI

controlled cryptographic items

CCP

circulation control point

CCTV

closed circuit television

CDR

commander

CE

U.S. Army Corps of Engineers

CECOM

U.S. Army Communications-Electronics Command

C-E

communications-electronics

CFM

cubic feet per minute

CG

commanding general

CL

carload

CMP

Civilian Marksmanship Program

COA

Comptroller of the Army

COCO

contractor-owned, contractor-operated

COE

Chief of Engineers

COFC

container-on-flatcar

COMDT

commandant

COMSEC

communications security

CONEX

container express

CONUS

continental United States

CONUSA

the numbered armies in the Continental United States

CPA

Chief of Public Affairs

CPCO

Central Post Call Office

CPR

civilian personnel regulation

CQ

charge of quarters

CRC

U.S. Army Crime Records Center

CSS

Constant Surveillance Service

CT

counterterrorism

CUCV

commercial utility and cargo vehicle

DA

Department of the Army

DAPSRB

Department of the Army Physical Security Review Board

DCSINT

Deputy Chief of Staff for Intelligence

DCSLOG

Deputy Chief of Staff for Logistics

DCSOPS

Deputy Chief of Staff for Operations

DCSPER

Deputy Chief of Staff for Personnel

DDPS

Dual Driver Protective Service

DEA

Drug Enforcement Administration

DEFCON

defense readiness condition

DEH

Director of Engineering and Housing

DLA

Defense Logistics Agency

DNA

Defense Nuclear Agency

DOD

Department of Defense

DODD

Department of Defense directive

DOL

Director of Logistics

DPDO

Defense Property Disposal Office

DRMO

Defense Reutilization Marketing Offices

DTS

Defense Transportation System

DUSD(P)

Deputy Under Secretary of Defense for Policy

EDD

explosives detector dog

ENTNAC

Entrance National Agency Check

EOC

Emergency Operations Center

EOD

explosive ordnance disposal

FAA

Federal Aviation Administration

FBI

Federal Bureau of Investigation

FISO

Force Integration Staff Officer

FM

field manual

FMS

foreign military sales

FOA

field operating agency

FOB

free on board

FSC

Federal supply classification

FY

fiscal year

GBL

Government bill of lading

GOCO

Government-owned, contractor-operated

GOGO

Government-owned, Government-operated

GS

greater security

GSA

General Services Administration

GT

general technical aptitude area

GTR

Government transportation request

HQDA

Headquarters, Department of the Army

HQMC

Headquarters, United States Marine Corps

HSP

high security padlock

HUMINT

human intelligence

ID

identification

IDS

intrusion detection system

IED

improvised explosive device

IES

Illuminating Engineering Society

ILS

integrated logistic support

INSCOM

U.S. Army Intelligence and Security Command

ITO

installation transportation office(r)

JCS

Joint Chiefs of Staff

JMSNS

Justification for Major System New Start

JROTC

Junior Reserve Officers' Training Corps

JRWG

Joint Requirements Working Group

J-SIDS

Joint-Service Interior Intrusion Detection System

JTAG

Joint Test Advisory Group

LAW

light antitank weapon

LCC

life cycle cost

LEA

law enforcement activity

LEC

law enforcement command

LIN

line item number

LOA

letter of agreement

LOI

Letter of Instruction

LR

letter requirement

LTC

lieutenant colonel

LTL

less than truckload

MAC

Military Airlift Command

MACOM

major Army command

MAJ

major

MATCU

military air traffic coordinating unit

MCA

major construction, Army

MEDCEN

U.S. Army Medical Center

MEDDAC

medical department activity

MEVA

mission essential or vulnerable area

MHE

materials handling equipment

MI

military intelligence

MILPO

military personnel office

MILSPEC

military specification

MILSTRIP

military standard requisitioning and issue procedures

MILVAN

military-owned demountable container

MIPR

military interdepartmental purchase request

MOS

military occupational specialty

MP

military police

MPA

military personnel, Army

MPI

Military Police Investigator

MSC

major subordinate command; Military Sealift Command

MSD

maximum stress diet

MSR

main supply route

MTOE/TDA

modified table of organization and equipment/table of distribution and allowances

MTMC

Military Traffic Management Command

MTX

Military Traffic Expediting Service

MUSAREC

major U.S. Army Reserve command

MWD

military working dog

NAF

non-appropriated fund

NATO

North Atlantic Treaty Organization

NBC

nuclear, biological, and chemical

NBS

National Bureau of Standards

NCDD

narcotics/contraband detector dog

NCEL

Naval Civil Engineering Laboratory

NCIC

National Crime Information Center

NCO

noncommissioned officer

NCOIC

noncommissioned officer in charge

NDA

National Defense Area

NDI

nondevelopmental item

NGR

National Guard regulation

NIS

Naval Investigative Service

NSN

national stock number

OACSI

Office of the Assistant Chief of Staff for Intelligence

OCE

Office of the Chief of Engineers

OCIE

organizational clothing and individual equipment

OCONUS

outside continental United States

OCPA

Office of the Chief of Public Affairs

ODCSLOG

Office of the Deputy Chief of Staff for Logistics

ODCSOPS

Office of the Deputy Chief of Staff for Operations

ODCSPER

Office of the Deputy Chief of Staff for Personnel

ODUSDP

Office of the Deputy Under Secretary of Defense for Policy

OJT

on-the-job training

OMA

Operation and Maintenance, Army

OMAR

Operation and Maintenance, Army Reserve

OPA

Other Procurement, Army

OPLAN

operation plan

OPM

Office of Personnel Management

OPSEC

operations security

OSD

Office of the Secretary of Defense

pam

pamphlet

PAO

public affairs officer

PAP

personnel assistance point

PARR

Program Analysis Resource Review

PCP

phencyclidine

PCS

permanent change of station

PDIP

Program Development Increment Package

PECIP

Productivity Enhancing Capitol Investment Program

PERSCOM

U.S. Total Army Personnel Command

PIF

productivity investment funding

PM

product manager; program manager; project manager; provost marshal

POC

point of contact

POD

port of debarkation

POE

port of embarkation

POL

petroleum, oils, and lubricants

POV

privately-owned vehicle

PPBES

Planning, Programming, Budgeting, and Execution System

PS

physical security

psi

pounds per square inch

PSC

physical security councils

PSE

physical security equipment

PSEAG

Physical Security Equipment Action Group

PSI

physical security inspector

PSS

Protective Security Service

PT

physical training

QPL

qualified products list

QRIP

Quick Return on Investment Program

RAM

reliability, availability, and maintainability

RAM-D

reliability, availability, maintainability, and durability

RC

Reserve component

RCS

reports control symbol

RDA

research, development, and acquisition

RDT&E

research, development, test, and evaluation

RDX

research department explosive

RESHIP

report of shipment

RF

radio frequency, response forces

RFP

request for proposal

ROC

required operational capability

ROTC

Reserve Officers' Training Corps

RSS

Rail Surveillance System

SCIF

sensitive compartmented information facilities

SECDEF

Secretary of Defense

SF

standard form

SFC

sergeant first class

SGA

standards of grade authorization

SJA

Staff Judge Advocate

SIR

serious incident report

SOFA

Status of Forces Agreement

SOP

standing operating procedure

SQT

skills qualification test

SRT

special reaction team

SSG

staff sergeant

SSN

social security number

SSS

Signature Security Service

SSSC

self-service supply center

TAADS

The Army Authorization Documents System

TAG

The Adjutant General

TASA

television audio support activity

TASC

training and audiovisual support center

TB

technical bulletin

TC

training circular

TCE

Technical Center of Expertise

TCP

traffic control point

TDA

tables of distribution and allowances

TDP

technical data package

TDY

temporary duty

THC

tetrahydrocannabinol

THREATCON

terrorist threat condition

TISA

Troop Issue Subsistence Activity

tl

truckload

TM

technical manual

TMDE

test, measurement, and diagnostic equipment

TMF

threat management force

TNT

trinitrotoluene

TOFC

trailer-on-flatcar

TOVEX

water gel (explosive)

TRADOC

U.S. Army Training and Doctrine Command

TSG

The Surgeon General

TSRWG

Tri-Service Requirements Working Group

TTS

technical training squadron

TTG

technical training group

TTW

technical training wing

UCMJ

Uniform Code of Military Justice

UL

Underwriter Laboratories

USACE

U.S. Army Corps of Engineering

USACIDC

United States Army Criminal Investigation Command

USAF

United States Air Force

USAISC

U.S. Army Information Systems Command

USAMPS

U.S. Army Military Police School

USAR

U.S. Army Reserve

USAREUR

U.S. Army, Europe, and Seventh Army

USC

United States Code

USMA

United States Military Academy

USS

United States standard

WSM-PSE

Weapons Systems Manager-Physical Security Equipment

WSN

weapon serial number

WTCA

Water Terminal Clearance Authority

Section II**Terms****Access (when pertaining to a restricted area or CCI)**

Personnel movement within a restricted area that allows the chance for visual observation of, or physical proximity to, either classified or protected materiel. It is also the ability and opportunity to obtain detailed knowledge of CCI through uncontrolled physical possession. External viewing or escorted proximity to CCI does not constitute access.

Aggressor

Any person seeking to compromise an asset. Aggressor categories include criminals, terrorists and protestors.

Ammunition

A device charged with explosives, propellants, pyrotechnics, initiating composition, riot control agents, chemical herbicides, smoke and flame, for use in connection with defense or offense, including demolition. Excluded from this definition are devices charged with chemical agents defined in JCS Pub. 1 and nuclear or biological materiel. Ammunition includes cartridges, projectiles, including missile rounds, grenades, mines, and pyrotechnics together with bullets, shot and their necessary primers, propellants, fuses, and detonators individually or having a unit of issue, container, or package weight of 100 pounds or less. Blank, inert training ammunition and caliber .22 ammunition are excluded.

Antiterrorism

Defensive measure used to reduce the vulnerability of individuals and property to terrorist acts, to include limited response and containment by military forces.

Armed Guard Surveillance

A service that provides armed guards to maintain constant and specific surveillance of shipments for which the service is requested. "Armed" is defined as having a firearm and appropriate ammunition readily available for immediate use. (DOD 5100.76-M)

Arms

A weapon included in AR 190-11, appendix A, that will or is designated to expel a projectile or flame by the action of the explosive, and the frame or receiver of any such weapon.

Asset

Any resource requiring protection.

Aviation Facility

A department of the Army activity or area collocated with facilities for the takeoff and landing of aircraft. The facility has the mission of command and control of administrative, operational, training, and/or logistical support of Army aviation.

Badge

A security credential that is worn on the possessor's outer garment and validates (his or her) authority for access to a restricted area.

Bulk Storage

Storage in a facility above the using or dispensing level specifically applicable to logistics warehouse and depot stocks. This applies to activities using controlled medical substances and items (such as pharmacies, wards, or clinics) only when a separate facility (building or room) is used to store quantities that exceed normal operating stocks.

Cable Seal Lock

A seal in which the cable is passed through the locking hardware of a truck trailer or railcar door and the bullet nose is inserted into the barrel and the end of the cable until securely anchored. Once locked any force exerted to separate the lockpoint from the lockbody will strengthen its connection. (DOD 5100.76-M)

Carrier Custodian

An employee who has been assigned responsibility for controlled shipments containing SECRET material by the carrier and who has been issued a personnel security clearance by the Government. (DOD 5100.76-M)

Certification

The process whereby a patrol or detector dog's and handler's proficiency is verified to be in compliance with minimum training standards.

Chains

Chains used to secure racks or containers will be of heavy-duty, hardened steel chain, welded, straight-link steel. The steel will be galvanized of at least 5/16-inch thickness or of equal resistance required to force, to cut, or break an approved low security padlock. An example of such a chain is Type 1, Grade C, Class 4 NSN 4010-0-149-5583, NSN 4010-00-149-5575, or NSN 4010-00-171-4427.

Closed Circuit Television

Television that serves a number of different functions, one of which is physical security. As it pertains to the field of physical security, CCTV is used to augment, not replace, existing intrusion detection systems (IDS) or security patrols. It is not used as a primary sensor, but rather as a means of assessing alarms. CCTV also may be used as a surveillance means, but if used in this way, it will augment, not replace, existing IDS.

Closed post

An army installation or activity to which ground and water access is controlled at all times by perimeter barriers with limited, manned entry control points.

Closed vehicle or equipment

A conveyance that is fully enclosed with permanent sides and a permanent top, with installed doors that can be locked and sealed. (DOD 5100.76-M)

Combatting Terrorism

Actions, including AT and CT, taken to oppose terrorism throughout the entire threat spectrum.

Commercial-type vehicle

A vehicle designed to meet civilian requirements, and used without major modifications, for routine purposes in connection with the transportation of supplies, personnel, or equipment.

Constant Surveillance Service

A service that is an integral part of the provisions of 49 CFR 397 (reference (b)) that a carrier must apply when transporting hazardous or Class A and B explosive materials. It provides constant surveillance over a shipment. The transporting conveyance containing the shipment must be attended at all times by a qualified representative of the carrier. A motor vehicle is "attended" when the person in charge of the vehicle is awake and not in a sleeper berth and

is within 100 feet of the vehicle, provided the vehicle is within the person's obstructed field of vision. The qualified representative "attending" the vehicle must:

- a. Be aware of the nature of the material contained in the vehicle.
- b. Have been instructed on procedures to follow in case of emergency.
- c. Be authorized to move the vehicle and have the means and capability to do so.

Note. CSS does not include a signature and tally service as provided under Signature Security Service (SSS). (DOD 5100.76-M)

Container Express

A reusable container for shipment of troop support cargo, quasi-military cargo, household goods, and personal baggage.

Containerization

A box or other device in which a number of packages are stored, protected, and handled as a unit in transit; for example, CONEX, MILVAN, and SEAVAN. This term also refers to the shipping system based on large cargo-carrying containers that can be easily interchanged between trucks, trains, and ships, without rehandling of contents. (DOD 5100.76-M)

Container on a flat car

A large box-like demountable body without undercarriage used to transport cargo that is mounted on a railroad flat car. (DOD 5100.76-M)

Constant Surveillance

Observing or protecting a storage facility containing AA&E by a human, intrusion detection system, closed circuit television, or combination, to prevent unobserved access, or make known any unauthorized access to the protected facility.

Continuous Surveillance

Constant unobstructed observance of items or an area to prevent unauthorized access. Continuous surveillance may be maintained by dedicated guards, other on-duty personnel, or intrusion detection systems and those enhanced by closed-circuit television.

Controlled Area

See restricted area.

Controlled cryptographic item

A secure telecommunications or information handling equipment ancillary device, or associated cryptographic component, which is unclassified but is controlled.

Controlled medical substance

A drug or other substance, or its immediate precursor, listed in current schedules of 21 USC 812 in medical facilities for the purpose of military treatment, therapy, or research. Categories listed in this section are narcotics, amphetamines, barbiturates, and hallucinogens.

Counterterrorism

Offensive measures taken to prevent, deter, and respond to terrorism.

Crime analysis

The process used to determine the essential features of a criminal act. It is a mandatory part of any crime prevention program.

Crime prevention

The anticipation, recognition, and appraisal of a crime risk, and initiation of some action to remove or reduce it. Crime prevention is a direct crime control method that applies to before-the-fact efforts to reduce criminal opportunity, protect potential human victims, and prevent property loss.

Crime prevention inspection

An on-site evaluation of the crime prevention program of a unit, section, office, or other facility.

Crime risk management

The development of systematic approaches to reduce crime risks.

Crisis management team

A team found at a major command or installation level. A crisis management team is concerned with plan, procedures, techniques, policies, and controls for dealing with terrorism, special threats, or other major disruptions occurring on Government installations and facilities. A crisis management team considers all aspects of the incident and establishes contact with the AOC.

Critical communications facility

A communications facility that is essential to the continuity of operations of the National Command Authority during the initial phases of national emergencies, and other nodal points or elements designated as crucial to mission accomplishment.

Cryptographic component

The embodiment of a cryptographic logic in either hardware or firmware form, such as a modular assembly, a printed circuit board, a microcircuit, or any combination of these.

Cryptographic equipment

Any equipment employing a cryptographic logic.

Cryptographic logic

A deterministic logic by which information may be converted to an unintelligible form and reconverted to an intelligible form. Logic may take the form of engineering drawings, schematics, hardware, or firmware circuitry.

Day gate

Any barriers, used in a doorway or entrance to pharmacy or medically sensitive item storage areas, that prevents unauthorized personnel access during operating hours. Such barriers normally are not the sole protection afforded the entrance during nonoperating hours; however, during operating hours, the barrier ensures positive entry control by on-duty personnel (for example, electronic buzzer control entry to the area after positive identification by receptionist or on-duty personnel).

Dedicated guards

Individuals charged with performing the primary task of safeguarding designated facilities, material, and personnel within a defined area during a tour of duty. A dedicated guard may perform this function as a static post. He or she remains within or on the perimeter of a protected area and maintains continuous surveillance over that which is being protected during the tour of duty.

Defense Transportation System

Consists of military controlled terminal facilities, Military Airlift Command (MAC) controlled airlift, Military Sealift Command (MSC) controlled or arranged sealift, and Government controlled air or land transportation. (DOD 5100.76-M)

Demilitarization

The act of destroying the offensive or defensive characteristics inherent in certain types of equipment and materiel. The term comprehends mutilation, scrapping, burning, or alteration designed so as to prevent the further use of such equipment and materiel for its originally intended military or lethal purpose.

Double-locked container

A steel container of not less than 26 gauge which is secured by an approved locking device and which encases an inner container that also is equipped with an approved locking device. Cabinet, medicine, combination with narcotic locker, NSN 6530-00-702-9240, or equivalent, meets requirements for a double-locked container.

Dromedary

A freight box carried on and securely fastened to the chassis of the tractor or on a flat-bed trailer. The dromedary is demountable by the use of a forklift truck, is protected by a plymetal shield, and is equipped with doors on each side that may be locked with seals or padlocks. All explosive items carried in the dromedary must be compatible and in compliance with 49 CFR 177 (ref (c)) or host nation regulations. (DOD 5100.76-M)

Dual Driver Protective Service

A service requiring SSS plus continuous attendance and surveillance of the shipment through the use of two drivers.

- a. The vehicle containing the shipment must be attended at all times by one of the drivers. A vehicle is attended

when at least one of the drivers is in the cab of the vehicle, awake, and not in a sleeper berth or is within 10 feet of the vehicle.

b. SSS signature and tally requirements are not required between the same pair of drivers for a particular movement. (DOD 5100.76–M)

Duress alarm system

A method by which authorized personnel can covertly communicate a situation of duress to a security control center or to other personnel in a position to notify a security control center. (DOD 5100.76–M)

Duress or holdup alarms

Devices which allow personnel on duty to transmit a signal to the alarm monitoring station from which an armed response force can be dispatched if a holdup or a duress situation occurs.

Emergency Aircraft

An aircraft designated by the commander to respond to emergency situations and provide life-saving and property-saving services. Normally, such aircraft has special equipment and markings. Air Ambulances and firefighting aircraft are examples.

Emergency vehicle

A vehicle designated by the commander to respond to emergency situations and provide life-saving and property-saving services. Normally, the vehicle has special equipment and markings. Ambulances and firefighting and military or security police vehicles are examples.

Enclosed vehicle or equipment

A conveyance that is fully enclosed with permanent sides and permanent top, with installed doors that can be locked and sealed.

Entry control (when pertaining to a restricted area)

Security actions, procedures, equipment, and techniques, employed within restricted areas to ensure that persons who are present in the areas at any time have authority and official reason for being there.

Escorted personnel (when pertaining to a restricted area)

Those persons authorized access to a restricted areas who are escorted at all times by a designated person.

Escorts and couriers

Military members, U.S. civilian employees, or DOD contractor employees responsible for the continuous surveillance and control over movements of classified material. Individuals designated as escorts and couriers must possess a Government-issued security clearance at least equal to that of the material being transported.

Exception

An approved permanent exclusion from specific requirements of this regulation. Exceptions will be based on a case-by-case determination and involve unique circumstances which make conformance to security standards impossible or highly impractical. An exception can also be an approved permanent deviation from the provisions of this regulation. There are two types of exceptions:

a. Compensatory Measures Exception. This is a deviation in which the standards are not being met, but the DOD component (HQDA(DAMO–ODL–S)) concerned determines it is appropriate, because of physical factors and operational requirements. Compensatory measures are normally required.

b. Equivalent Protection Exception. This is a deviation in which nonstandard conditions exist, but the totality of protection afforded is equivalent to or better than that provided under standard criteria.

Exclusion area

See restricted area.

Exclusive use

A conveyance unit or vehicle that is used only for a shipment from origin to destination without transfer of lading, and that permits locking of the unit and use of seals. (DOD 5100.76–M)

Explosives

Any chemical compound, mixture or device, the primary or common purpose of which is to function by explosion. The term includes, but is not limited to, individual land mines, demolition charges, blocks of explosives (dynamite,

trinitrotoluene (TNT), C-4, and other high explosives), and other explosives consisting of 10 pounds or more; for example, gunpowder or nitroguanidine.

Facility

Any single building, project, or site.

Force Protection

Security program developed to protect soldiers, civilian employees and family members, facilities and equipment, in all locations and situations. This is accomplished through the planned integration of combatting terrorism, physical security, operations security, protective services and law enforcement operations, all supported by foreign intelligence, counterintelligence and other security programs.

Greater security (GS)

A seal tracing and inspection rail service for unclassified sensitive cargo that includes a military traffic expending (MTX) service and provides:

- a. Inspection of railcars at major terminals by railroad personnel for evidence of forced entry or tampering with seals or security devices.
- b. Name of carrier reporting.
- c. Time of inspection; that is, a.m. or p.m.
- d. Actual arrival and actual departure time from inspection terminal. (DOD 5100.76-M)

Handler

A military police person or DOD civilian guard or police person who has been qualified by training and certification to care for, train, and employ a military working dog.

Handling

Controlled physical possession without access.

High risk personnel

Personnel who, by their grade, assignment, value, location, or specific threat, are more likely to be attractive or accessible terrorist targets.

Independent power source

A power source, normally battery, independent of any other source (DOD 5100.76-M)

Industrial and utility equipment

Equipment used in the manufacture or in support of the manufacture of goods and equipment used to support the operation of utilities such as power and water distribution and treatment.

In flight

The condition of an aircraft from the moment when all external doors are closed following embarkation until the moment when one such door is opened for disembarkation.

Installations

Such real properties as reserve centers, depots, arsenals, ammunition plants (both contractor- and Government-operated, hospitals, terminals, and other special mission facilities, as well as those used primarily by troops. (See also JCS Pub. 1)

Internal controls (when pertaining to a restricted area)

Security actions, procedures, and techniques employed within restricted areas to ensure persons who are present in these areas at any time have authority and official reason.

Intrusion detection system

The combination of electronic components, including sensors, control units, transmission lines, and monitoring units integrated to be capable of detecting one or more types of intrusion into the area protected by the system and reporting directly to an alarm monitoring station. The IDS will be an approved DOD standardized system, such as the Joint Service Interior Intrusion Detection System or MACOM-approved commercial equipment.

Justification for Major System New Start

A requirement document that the combat developer prepares with the material developer, training developer, manpower

and personnel planner, and logistician. A JMSNS is prepared to describe the mission need and justifies the acquisition of a major new system at program initiation in the acquisition cycle.

Kennel facilities

The buildings, the kennels, the runs, and the exercise and training areas which are used to house, care for, and train military working dogs.

Key and lock control system

A system of identifying both locks and their locations and personnel in possession of keys and/or combinations.

Keying

The process of establishing a sequence of random binary digits used to initially set up and periodically change permutations in cryptographic equipment for purpose of encrypting or decrypting electronic signals, for controlling transmission security processes, or for producing other keys.

King Tut block

A King Tut block is a specially designed large concrete block. It is placed in front of an igloo or magazine entrance with a fork lift. Access to the igloo or magazine therefore requires a fork lift to move the block. The King Tut block is of sufficient weight to prevent removal without a fork lift.

Letter of agreement

A document jointly prepared and signed by the combat and materiel developers when a potential materiel system need has been identified and it has been determined that one or more technological approaches may satisfy the need. Even though it may be in an early stage of development, the LOA will address the materiel system from the Total System Management standpoint. The LOA describes operational, technical, training, personnel, and logistical system unique events that must be undertaken to produce the total system.

Letter requirement

An abbreviated procedure for acquisition of low-unit cost, low-risk developmental, or commercial items. It will be used instead of the ROC when applicable. The total system definitive requirements for training, personnel, and logistics requirements are the same for the LR as for the ROC. The LR is jointly prepared by TRADOC and AMC.

Lightweight construction

Building construction other than reinforced concrete or masonry (concrete block or clay brick) such as wood or metal siding.

Limited access post

An Army installation or activity that meets one of the criteria below:

- a.* No permanent fences or other physical barriers exist, but entry can be temporarily closed to vehicular traffic and other movements using roads and other conventional points of entry.
- b.* Permanent perimeter barriers exist and access is controlled only after normal duty hours; for example, gates are secured or manned with guards after dark.
- c.* No permanent perimeter barriers exist, but vehicular traffic and other movements using roads and other conventional points of entry are continuously controlled.

Limited area

See restricted area.

Locked container

A container or room of substantial construction secured with an approved locking device. For pharmacy operating stocks, lockable automated counting systems meet requirements for a locked container.

Locking devices

- a.* Padlocks, military specifications MIL-P-43607 (High Security Padlock); shrouded shackle, NSN

5340-01-217-5068 or horizontal sliding bolt, NSN 5340-00-799-8248) or MIL-P-43951 (medium security padlock; regular shackle, NSN 5340-00-799-8016).

b. Padlocks, Commercial Item Description A-A-1927 (low security padlock) having a hardened steel shackle and body; NSN 5340-00-158-3807 (with chain), NSN 5340-00-158-3805 (without chain).

c. GSA-approved changeable three-position padlock, Federal Specification FF-P-110.

d. High security hasps. Military Specifications MIL-H-43905 or MIL-H-29181A.

e. Hasps and staples for low-security padlocks which are of heavy pattern steel, securely fastened to the structure with smooth-headed bolts, rivets, or welding to prevent removal.

Locks

Locks should be considered as delay devices only, not as positive bars to unauthorized entry, since any lock can be defeated by expert manipulation or force.

a. Padlocks

High security padlocks: Military Specification MIL-P-43607, shrouded shackle with clevis and chain, NSN 5340-01-217-5068 or NSN 5340-00-188-1560; horizontal sliding bolt with clevis and chain, NSN 5340-00-799-8248.

Medium security padlocks: Military Specification MIL-P-43951, open shackle with clevis and chain, NSN 5340-00-799-8016. Authorized for continued use to secure Categories III and IV AA&E only until stocks are depleted or replaced.

Low security padlocks: Commercial Item Description A-A-1927, hardened steel shackle and case, without chain: NSN 5340-00-158-3805; with chain: NSN 5340-00-158-3807.

(Any questions regarding the above specifications will be addressed to the DOD Lock Program Technical Manager, Naval Facilities Engineering Service Center, Code C66, 560 Center Drive, Port Hueneme, CA 93043-4328 (DSN 551-1567 or -1212).

b. Certain locks, such as high or medium security padlocks, provide excellent protection when used in conjunction with a high security hasp. Hasps installed for protection of AA&E will provide protection comparable to that given by the lock used. Determination of "comparable protection" will be addressed to the DOD Lock Program Technical Manager, Naval Civil Engineering Laboratory, Code L56, 560 Center Drive, Port Hueneme, CA 93043-4328 (DSN 551-1567 or -1212).

NAPEC high security shrouded hasp (MIL-H-29181A) is approved for use with the high security padlock to secure all categories of AA&E. The hasp has a cover that protects the lock from cutting or hammer tools and inclement weather. It should be used to secure Category I and II AA&E storage facilities. When replacement of a hasp on Category III, IV or uncategorized AA&E is necessary, this hasp should also be used. The Natick high security hasp (MIL-H-43905) is a high security hasp that also is approved for protection of Category III and IV AA&E when used with an approved high security padlock.

Hasp, pin-type, locking "T" is a hasp that was authorized previously to secure ammunition storage magazines. Magazines were secured using the installed locking bar in conjunction with a "T" pin and high security padlock. The locking "T" hasp does not provide adequate security for sensitive AA&E. It must be replaced with a high security hasp to enhance security. It will not be used to secure Category I and II ammunition storage facilities.

c. Another lock is the cable seal lock. Once locked, any force exerted to separate the lockpoint from the lockbody strengthens the connection. Such locks are not approved for use in securing storage facilities containing AA&E. The same restriction applies to d below.

d. A complementary device to locks is the No. 5 American Wire Gauge wire twist. This is a U-shaped wire placed in the hasp along with the shackle and twisted tightly in place. Another device is a wire cable of a thickness equivalent to or larger than No. 5 wire. This is placed through the hasp, a metal sleeve slipped over it, and crimped into place.

e. Built-in combination locks, meeting Underwriters Laboratories Standard 768, Group 1 (NSN 5340-01-375-7593) are approved for use on GSA-approved Class 5 vault doors and GSA-approved Class 5 weapons containers storing unclassified material and unclassified AA&E.

LOGAIR

Long-term contract airlift service within the continental United States for the movement of cargo in support of the logistics system of the Military Services (primarily the Army and Air Force) and Defense Agencies. (DOD 5100.76-M)

Major disruption on installations

Acts. Threats, or attempts to commit such acts as kidnapping, extortion, bombings, hijackings, ambushing, major weapons thefts, arson, assassination, and hostage taking on a military installation. These acts that have potential for widespread publicity require special response, tactics, and management.

Medically sensitive items

Standard and nonstandard medical items designated by medical commanders to be sufficiently sensitive to warrant a

stringent degree of physical security and accountability in storage. Included within this definition are all items subject to misappropriation and/or misuse such as needles and syringes.

Military Traffic Expediting (MTX) Service

A service providing for movement from origin to destination in the shortest time possible for specifically identified rail shipments, and which is required for the shipment of firearms and other sensitive shipments. This service uses electrical communications between members of the Association of American Railroads, is available for either single line haul or jointline movements, and provides progress reports as required. (DOD 5100.76-M)

Military van (MILVAN)

Military-owned demountable container, conforming to U.S. and international standards, operated in a centrally controlled fleet for movement of military cargo. (DOD 5100.76-M)

Military working dog

Dogs required by the using DOD component for a specific purpose, mission, or combat capability. MWDs include patrol, patrol and narcotic/contraband, and patrol and explosive detector dogs.

Military working dog team

The MWD and its appropriately qualified, assigned handler.

Mission-critical personnel

Personnel who are essential to the operation of an organization of function.

Mission essential and vulnerable areas

Facilities or activities within the installation that, by virtue of their function, are evaluated by the commander as vital to the successful accomplishment of the installation's State National Guard, or MUSARC mission. This includes areas nonessential to the installation's/facility's operational mission but which, by nature of the activity, are considered vulnerable to theft, trespass, damage, or other criminal activity.

Motor pool

A group of motor vehicles used as needed by different organizations or individuals and parked in a common location when not in use. On an Army installation, a nontenant Army activity with 10 or less assigned commercial-type vehicles but no local organizational maintenance support does not have a motor pool, under this regulation, even though the vehicles are parked together.

Motor vehicle

A self-propelled, boosted, or towed conveyance used to transport a burden on land. This includes all Army wheeled and track vehicles, trailers, and semitrailers, but not railroad locomotives and rolling stock.

National Defense Area

An area set up on non-Federal lands located within the United States, its possessions or territories, to safeguard classified defense information or DOD equipment or materiel. Establishment of a National Defense Area temporarily places such non-Federal lands under the effective control of DOD and results only from an emergency event.

Negotiations

A dialogue between authorities and offenders which has as the ultimate goal for the safe release of hostages and the surrender of the offenders.

Note C controlled medical items

Sets, kits, and outfits containing one or more component Note Q or Note R items.

Note Q controlled medical items

All standard drug items identified as Note Q in the Federal Supply Catalog, Nonstandard Drug Enforcement Administration (DEA) Schedule III, IV, V Controlled Substances.

Note R controlled medical items

All items identified as Note R in the Federal Supply Catalog, Nonstandard DEA Schedule II Controlled Substances.

One dog-one handler

The concept that each MWD will have only one handler. Personnel shortages may necessitate assigning a handler responsibility for more than one dog. However, two or more handlers cannot handle the same dog.

Open post

Installations or activities that do not qualify as closed or limited access posts. Access to the installation or activity is not controlled during or after normal duty hours.

Perimeter fence

Fences for the security of unclassified, non-sensitive items that meet the requirements of U.S. Army Corps of Engineers Drawing Code STD 872-90-00 Series. The minimum height will be 6 feet. Use of NATO Standard Design Fencing is also authorized.

Perimeter wall

Any wall over 6 feet tall which delineates a boundary and serves as a barrier to personnel and/or vehicles. These walls may be constructed of reinforced concrete, masonry, or stone.

Physical protective measures

Physical security measures used to counter risk factors that usually do not change over a period of time such as mission impact, cost, volume, and criticality of resources and vulnerabilities. The measures are usually permanent and involve expenditure of funds.

Physical security

That part of the Army security system, based on threat analysis, concerned with procedures and physical measures designed to safeguard personnel, property, and operations; to prevent unauthorized access to equipment, facilities, materiel, and information; and to protect against espionage, terrorism, sabotage, damage, misuse, and theft. Operations security (OPSEC) and security targeted against traditional criminal activity are included.

a. Physical security procedures include, but are not limited to, the application of physical measures to reduce vulnerability to the threat; integration of physical security into contingency, mobilization, and wartime plans; the testing of physical security procedures and measures during the exercise of these plans; the interface of installation OPSEC, crime prevention and physical security programs to protect against the traditional criminal; training of guards at sensitive or other storage sites in tactical defense against and response to attempted penetrations; and creating physical security awareness.

b. Physical security measures are physical systems, devices, personnel, animals, and procedures employed to protect security interests from possible threats and include, but are not limited to, security guards; military working dogs; lights and physical barriers; explosives and bomb detection equipment; protective vests and similar equipment; badging systems; electronic entry control systems and access control devices; security containers; locking devices; electronic intrusion detection systems; standardized command, control, and display subsystems; radio frequency data links used for physical security; security lighting; delay devices; artificial intelligence (robotics); and assessment and/or surveillance systems to include closed-circuit television. Depending on the circumstances of the particular situation, security specialists may have an interest in other items of equipment such as armored sedans.

Physical security equipment

A generic term for any item, device, or system that is used primarily to protect Government property, including nuclear, chemical, and other munitions, personnel, and installations, and to safeguard national security information and material, including the destruction of such information and material both by routine means and by emergency destruct measures.

a. Interior physical security equipment. Physical security equipment used internal to a structure to make that structure a secure area. Within DOD, DA is the proponent for those functions associated with development of interior physical security systems.

b. Exterior physical security equipment. Physical security equipment used external to a structure to make the structure a secure area. Within DOD, the Department of the Air Force is the proponent for those functions associated with the development of external physical security systems; however, the Army will develop lights, barriers, and robotics.

c. Intrusion detection system. See previous definition.

Physical security inspection

A formal, recorded assessment of physical procedures and measures implemented by a unit or activity to protect its assets.

Physical security measures

See physical security.

Physical security plan

A comprehensive written plan providing proper and economical use of personnel, land, and equipment to prevent or minimize loss or damage from theft, misuse, espionage, sabotage, and other criminal or disruptive activities.

Physical security procedures

See physical security.

Physical security program

The interrelationship of various components that complement each other to produce a comprehensive approach to security matters. These components include, as a minimum, the physical security plan; physical security inspections and surveys; participation in combatting terrorism committees and fusion cells; and a continuing assessment of the installation's physical security posture.

Physical security resource plan

Plan developed by the physical security officer that identifies physical security needs, and shows proposed programmed procurement of those needs.

Physical security survey

A formal, recorded assessment of the installation physical security program.

Physical security system architecture

A system ensuring that IDS components designed by the various services are compatible when used together. The Air Force is responsible for systems architecture.

Pier service

Ocean carrier booking is restricted over ocean movement from port of embarkation (POE) to port of debarkation (POD). It precludes prearranged-through-booking employing surface transportation to inland destinations. (DOD 5100.76-M)

Pilferable assets

Any asset which can be stolen and which does not fall under the other asset categories discussed in this publication.

Pilferage-coded items

Items with a code indicating that the material has a ready resale value or civilian application and, therefore, is especially subject to theft.

Portable

Capable of being carried in the hand or on the person. As a general rule, a single item weighing less than 100 pounds (45.34 kilograms) is considered portable.

Primary electrical power source

That source of power, either external (commercial) or internal, that provides power to site facilities on a daily basis. (DOD 5100.76-M)

Protection in depth

A system providing several supplementary security barriers. For example, a perimeter fence, a secure building, a vault, and a locked container provide four layers of protection. (DOD 5100.76-M)

Protective layer

Any envelope of building components which surrounds an asset and delays or prevents aggressor movement toward the asset or which shields the asset from weapons and explosives effects.

Protective Security Service

A service to protect shipments. PSS involves a transporting carrier that must be a "cleared carrier" under provisions of DOD 5220.22-R, paragraph 1-702.a (ref (d)). A shipment must be under the constant surveillance of designated carrier employees, unless it is stored in containers or an area approved by the cognizant Defense Investigative Service regional

office. The designated carrier employees providing constant surveillance when PSS is required must possess a Government-issued SECRET clearance and a carrier-issued identification. (DOD 5100.76-M)

QUICKTRANS

Long-term contract airlift service within the continental United States (CONUS) for the movement of cargo in support of the logistic system for the Military Services (primarily the Navy and Marine Corps) and Defense agencies. (DOD 5100.76-M)

Rail Surveillance Service

An inspection service of rail shipments. An inspection is made within one hour after each stop, if the trailer containing a shipment remains at a halt. Reinspection is made a minimum of once each hour, as long as the railcar containing the shipment remains at a halt. (DOD 5100.76-M)

Report of Shipment

An advanced report furnished by message or telephone immediately upon dispatch of a shipment within CONUS for domestic shipments. A report goes to both Water Terminal Clearance Authority (WTCA) and the water port transshipping facility for surface export shipments, or to the Military Air Traffic Coordinating Officer (MATCO) for air export shipments. The advance notice of shipments shall include the following applicable data:

a. For domestic shipments, see AR 55-355/NAVSUPINST 4600.70/AFM 75-2/MCO P4600.14A/DLAR 4500.3, Routing Instruction Note (RIN) 146, Appendix L (reference (e)).

b. For export shipments, see chapter 4, DOD 4500.32-R (reference (f)). (DOD 5100.76-M)

Required operational capability

A requirements document that the combat developer prepares with input from the training developer in coordination with the material developer, logistician, and manpower and personnel planner. The ROC is a concise statement of the minimum essential operational, RAM, technical, personnel and manpower, training, safety, health, human factors engineering, logistical, and cost information to start full scale development or procurement of a material system.

Restricted area

Any area to which entry is subject to special restrictions or control for security reasons or to safeguard property or material. This does not include those designated areas over which aircraft flight is restricted. Restricted areas may be of different types. The type depends on the nature and varying degree of importance, from a security standpoint, of the security interest or other matter contained therein.

a. *Exclusion area.* A restricted area containing—

(1) A security interest or other matter of such nature that access to the area constitutes, for all practical purposes, access to such security interests or matter; or—

(2) A security interest or other matter of such vital importance that proximity resulting from access to the area is treated equal to (1) above.

b. *Limited area.* A restricted area containing a security interest or other matter, in which uncontrolled movement will permit access to such security interest or matter; access within limited areas may be prevented by escort and other internal restrictions and controls.

c. *Controlled area.* That portion of a restricted area usually near or surrounding an exclusion or limited area. Entry to the controlled area is restricted to authorized personnel. However, movement of authorized personnel within this area is not necessarily controlled. Mere entry to the area does not provide access to the security interest or other matter within the exclusion or limited area. The controlled area is provided for administrative control, safety, or as a buffer zone for security in depth for the exclusion or limited area. The proper commander establishes the degree of control of movement.

Ride awhile-walk awhile method

A law enforcement or security patrolling technique. The MWD team patrols for a period of time in a vehicle and then dismounts for an appropriate period of time to patrol an area on foot. This method increases the potential area the team can cover, as well as allowing the team to concentrate their foot patrols in especially critical areas.

Risk

The degree or likelihood of loss of an asset. Factors that determine risk are the value of the asset to its user in terms of mission criticality, replaceability, and relative value and the likelihood of aggressor activity in terms of the attractiveness of the asset to the aggressor, the history of or potential for aggressor activity, and the vulnerability of the asset.

Risk analysis

Method of examining various risk factors to determine the risk value of likelihood of resource loss. This analysis will be used to decide the level of security warranted for protection of resources.

Risk factors

Elements that make up the total degree of resource loss liability. Factors to be considered in a risk analysis include the importance of the resource to mission accomplishment; the cost, volume, criticality and vulnerabilities of the resources; and the severity of threats to the resources.

Risk level

An indication of the degree of risk associated with an asset based on risk analysis. Risk levels may be Levels I, II, or III, which correspond to low, medium, and high.

Risk value

Degree of expectation or likelihood of resource loss. The value may be classified as low, medium, or high.

Safe

A GSA Class 5 Map and Plans Security Container, Class 6 Security Filing Cabinet or refrigerator or freezer, secured with an approved locking device and weighing 500 pounds or more, or secured to the structure to prevent removal.

Schedule I drug

Any drug or substance by whatever official name (common, usual, or brand name) listed by the DEA in Title 21 of the Code of Federal Regulations, chapter II, Section 308.11, intended for clinical or non-clinical use. A list of Schedule I drugs and substances is contained in AR 40-7, appendix A.

Seal

A device to show whether the integrity of a shipment has been compromised. Seals are numbered serially, are tamperproof, and shall be safeguarded while in storage. The serial number of a seal shall be shown on Government Bills of Lading (GBL). A cable seal lock provides both a seal and locking device.

Sealed containers

Wooden boxes, crates, metal containers, and fiber containers sealed in a way to show when the containers are tampered with after sealing. The method of sealing depends of the type of construction of the containers. Sealing may be by metal banding, nailing, airtight sealing, or wax dripping (for fiber containers). In key control, a sealed container is also a locked key container or a sealed envelope containing the key or combination to the key container.

Sealed protection

A container or an area enclosed by a plastic or soft metal device which is opened easily without the use of a key or combination.

SEAVAN

A commercial, Government-owned or leased shipping container and without bogey wheels attached that is moved by ocean transportation and must be lifted on and off the ship. (DOD 5100.76-M)

Security card

An official distinctive identification (pass or card) that identifies and authorizes the possessor to be physically present in a U.S. Army designated restricted area.

Security engineering

The application of engineering principles to the protection of assets against various threats through the application of construction and equipment application.

Security lighting

The amount of lighting necessary to permit visual surveillance by security police or by supervisory personnel.

Security procedural measures

Physical security measures to counter risk factors that will periodically change over a period of time such as criminal, terrorist, and hostile threats. The procedures can usually be changed within a short amount of time and involve manpower.

Sensitive conventional arms, ammunition, and explosives

See categorization of such items in appendix A, AR 190–11.

Sensitive items

Material requiring a high degree of protection to prevent unauthorized acquisition. This includes arms, ammunition, explosives, drugs, precious metals, or other substances determined by the Administrator, Drug Enforcement Administration to be designated Schedule Symbol II, III, IV, or V under the Controlled Substance Act of 1970.

Signal intelligence

Intelligence derived from communications means (such as telephone, telegraph, radio), electronic signal emitters (such as navigation radar, identification friend or foe, and weapons guidance devices) and instrumentation signals (such as telemetry and beaconry).

Signature Security Service

A service designed to provide continuous responsibility for the custody of shipments in transit. A signature and tally record is required from each person responsible for the proper handling of the shipment at specified stages of its transit from origin to destination.

a. The initial signature on the signature and tally record should be the same as that of the carrier's agent on the GBL. When SSS is used in conjunction with DDPS, both drivers in each pair of drivers shall sign the signature and tally record when that pair assumes responsibility for the shipment.

b. Commercial carriers offering SSS must be able to trace a shipment in less than 24 hours. The following forms shall be used to obtain SSS:

(1) *Surface shipments.* DD Form 1907 (Signature and Tally Record) shall accompany every surface shipment of classified or protected material accorded a signature and tally service by surface commercial carriers. Carrier tariffs and tenders may describe this type of service under different titles for example, Hand-to-Hand Signature Service or Signature Service.

(2) *Commercial air shipments.* The air industry internal Form AC–10 (Airlines Signature Service Record) shall be used by regulated and nonscheduled airlines to obtain the signature and tally record. Air taxi operators and air freight forwarders providing SSS may use DD Form 1907 instead of AC–10. No receipt is required from the flight crew or attendants while the aircraft is in flight. A signature and tally record is required; however, from air carrier personnel whenever the aircraft is on the ground and access to the cargo compartment containing the sensitive arms, ammunition, and explosives (AA&E) is available for any purpose. A signature and tally record is also required from pickup and delivery carriers used by the airlines for such purposes.

(3) *Military air shipments.* The AF Form 127 (Traffic Transfer Receipt) or similar document, will be used to provide hand-to-hand receipt control for sensitive and classified shipments being transferred in the DTS. (DOD 5100.76–M)

Steel bar

A flat bar, 3/8 inch by one inch minimum; or round bar 1/2 inch diameter minimum.

Steel mesh

High carbon, manganese steel not less than 15/100 inch (8-gauge) in thickness, and a grid of not more than two inches center to center.

Storage

Any area where AA&E are kept. Storage does not include items in process of manufacture, in use, or being transported to a place of storage or use.

Survivability

The ability to withstand or repel an attack, or other hostile action, to the extent that essential functions can continue or be resumed after the hostile action.

Tactics

The specific methods of achieving the aggressor's goals to injure personnel, destroy Army assets, or steal Army materiel.

Tactical vehicle

A vehicle with military characteristics designed primarily for use by forces in the field in direct connection with, or support of, combat or tactical operations, or the training of troops for such operations.

Tenant activity

A unit or activity of one Government agency, military department, or command that occupies facilities on an installation of another military department or command and that receives supplies or other support services from that installation.

Terrorism

The calculated use of violence or the threat of violence to inculcate fear; intended to coerce or to intimidate governments or societies in the pursuit of goals, that are generally political, religious, or ideological.

Terrorism counteraction measures

Term used previously for combatting terrorism (see definition of this term).

Terrorist group

A politically, religious, or ideologically oriented group which uses terrorism as its prime mode of operations.

Threat management force

An action force from the installation that responds to major disruptions on installations. The TMF should be of sufficient size to manage the disruption and will usually involve a command element, security element, negotiation team, SRT, and logistical element.

TOW

A tube-launched, optically traced, wire-command missile designed as an antitank weapon system. (DOD 5100.76-M)

Upper rail loc

A set screw operated variation of a "C" clamp designed for gripping the upper sliding rail which supports or guides the weight of some styles of railroad boxcar doors. Gripping the upper sliding rail, the "loc" blocks and prevents the door's roller hangers or carriers from sliding past, thereby effectively preventing the door from being moved. (DOD 5100.76-M)

Waiver

Temporary relief from specific standards imposed by this manual (regulation) pending actions accomplishment of actions that will conform to the standards required. Compensatory measures are required.

Section III**Special Abbreviations and Terms**

There are no entries in this section.

Index

This index is organized alphabetically by topic and by subtopic within topic. Topics and subtopics are identified by paragraph number.

Abbreviations. See **glossary**

Advantages, dogs, 1–8

Alarms, response, 2–5

Alert, positive response, 2–42

Animals, stray, 1–28

Area defense, 2–27

Artificial respiration, 6–16

Authorization, MWD, 1–14

Authorized MWD, requesting, 1–14

Bloat, 6–21

Bomb threat

 Planning, 2–40

 Response, 2–41

Building, searches, 2–6

Burns, 6–14

Care of dogs, 6–22 to 6–24

Certification

 Explosives detector dog, 2–39

 Narcotics detector dog, 2–35

 Postgraduation, 3–18 to 3–26

 Requirements, 3–10 to 3–17

Close boundary posts, 2–22

Combat patrols, 2–29

Competitive events, 1–25

Controlled aggression, 3–12, 3–21

Controlled substance

 Accountability, 4–4

 Destruction, 4–5

 Issue/turn-in, 4–7

 Procurement, 4–3

 Security, 4–6

 Synthetic drugs, 4–9

 Weight checks, 4–6

Crowd control, 2–17

CTA 50–900, 8–4

CTA 50–970, 8–5

DEA, registration, 4–1, 4–2

Decertification

 Explosives detector dog, 2–39

 Narcotics detector dog, 2–35

Decoys, 3–7

Degrees of criticality, 3–9

Deployment, 2–31

Detector dog

 Explosives, 3–29

 Narcotics, 3–28

 Proficiency evaluation, 3–31

 Proficiency training, 3–30

Diseases

 And parasites, 6–3 to 6–8

 Contagious, 6–4

 Noninfectious, 6–8

- Prevention, 6-3
- Distant support posts, 2-21**
- Dogs**
 - Feeding, 6-24
 - Privately owned, 1-28
 - Stray, 1-28
- Duties, kennelmaster, 1-19**
- EPW operations, 2-30**
- Equipment**
 - Authority, 8-1
 - Care, 8-6
 - Initial issue, 8-2
 - Organizational, 8-3
 - Obtaining, 1-16
 - Weight scale, 8-8
- Exercise area, 7-27**
- Explosives**
 - Authorized training aids, 5-2
 - Characteristics, 5-3
 - Cutting training aids, 5-5
 - Detector dogs, legal, 2-38
 - Detector dogs, 2-36 to 2-43
 - Safety, 5-9
 - Safety requirements, 5-11
 - Safety training, 5-10
 - Selecting facilities for detector dog training, 5-1
 - Storage, 5-6
 - Training aid, 5-1 to 5-11
- Feeding, 6-24**
- Fencing, kennel, 7-23**
- First aid**
 - Artificial respiration, 6-16
 - Bloat, 6-21
 - Burns, 6-14
 - Foreign object, 6-18
 - Fractures, 6-12
 - General, 6-10
 - Overheating, 6-20
 - Poisonous substance, 6-19
 - Shock, 6-15
 - Snake bite, 6-17
 - Wounds, 6-13
- Fractures, 6-12**
- Grooming and inspection, 6-23**
- Gunfire, 3-14, 3-23**
- Handlers, 1-19, 1-20**
- History, 1-5**
- Intrusion detection system, 2-23**
- Incident reporting, 2-44**
- Inspection**
 - Dogs, 9-7, 9-8
 - Equipment, 9-5, 9-6
 - Explosives training aids, 9-17
 - Facilities, 9-2 to 9-4

- Grooming, 6–23
- Guidelines, 9–1
- Handler knowledge, 9–14
- Kennels, 9–2
- Kennel support building, 9–3
- Leather/metal, 9–5
- MWD appearance, 9–7
- MWD physical condition, 9–8
- MWD proficiency, 9–15
- Narcotics training aids, 9–16
- Records, 9–18 to 9–21
- Supplies, 9–6
- Training/exercise area, 9–4
- Training of MWD, 9–13
- Use of MWD, 9–13
- Veterinary support, 9–9 to 9–11

Kennel

- Air-conditioning, 7–12
- Components, 7–3
- Construction approval, 1–11
- Electrical, 7–16
- Facilities, 7–1 to 7–40
- Fencing, 7–23
- Frigid climate, 7–14
- Heating, 7–11
- Maintenance, 7–28
- Master planning, 7–2
- Parking, 7–24
- Plumbing, 7–15
- Requirement, 7–1
- Risk analysis, 7–37
- Safety measures/procedures, 7–30
- Security requirements, 7–37 to 7–40
- Semi-permanent, 7–8
- Standardization, 7–4
- Support, 1–19
- Support facilities, 7–1 to 7–27
- Temperate climate, 7–13
- Ventilation, 7–10

Kennelmaster, 1–19

Listening posts, 2–29

Locks, 8–9

Maintenance and sanitation, 7–28

Manpower, requirements, 1–13

Medication and first aid, 6–9 to 6–24

Mission, combat support, 2–26

Missions, identifying, 1–10

Mobilization, 2–31

MWD

- Control, 1–27
- Disabled, 1–23
- Feeding, 6–24
- General, 1–21
- Health, care, and feeding, 6–1 to 6–24
- Replacement, 1–22

- Section composition, 1–18
- Section organization, 1–17
- Team, employment, 1–24
- MWD program, 1–11**
- Narcotics detector dogs, 2–32 to 2–35**
- Narcotics detector dogs, legal, 2–34**
- Obedience, commands, 3–10, 3–19**
- Obedience course, 3–11, 3–20, 7–26**
- One dog–one handler, 1–26. See Glossary**
- Overheating, 6–20**
- Parasites, 6–5 to 6–7**
- Parking lots, 2–7**
- Patrol, vehicle, 2–4, 3–16, 3–25**
- Patrol, walking, 2–3**
- Patrolling, 3–15, 3–24**
- Perimeter post, 2–21**
- Physical restraint, 6–11**
- Proficiency**
 - Detector dog, 3–35
 - Standards, 3–8, 3–9
 - Training, 3–1 to 3–7
- Purpose, 1–1**
- Reconnaissance, 2–29**
- Records**
 - Daily feeding, 3–34
 - MWD training/utilization, 3–34
 - Narcotics/explosives training/utilization, 3–35
 - Training/utilization, 3–33 to 3–35
- References. See appendix A**
- Registration with DEA, 4–1, 4–2**
- Requirements**
 - Hot weather, 7–35
 - Kennel, 7–1
 - Sanitation, 6–22
- Response forces, 2–25**
- Response warning, combat support operations, 2–28**
- Responsibilities**
 - Air Force, 1–6
 - General, 1–6
 - Kennelmaster, 1–19
 - Veterinary, 6–2
- Risk analysis, kennel, 7–37**
- Role, MWD, 1–6**
- Safety**
 - Explosives training aids, 5–11
 - Measures/procedures, 7–30
 - Training area, 7–31
 - Veterinarian facility, 7–32
- Sanitation, required, 6–22**
- Scouting, 3–15, 3–24**
- Search, building, 3–13, 3–22**
- Security**
 - Design, 7–38
 - Kennel, 7–40

- Mobile patrols, 2–24
- Operational, 7–39
- Planning, 2–19
- Post selection, 2–20
- Requirements for kennels, 7–37 to 7–40
- Senses, superiority, 1–9**
- Shock, 6–15**
- Site, kennel, 7–5**
- Small arms fire, 3–14, 3–23**
- Snake bite, 6–17**
- Standards**
 - Certification, 3–18
 - Detector dog certification, 3–27
 - Proficiency, 3–8
- Terms. See glossary**
- Test, validation, 3–32**
- Tracking, 3–17, 3–26**
- Trainer, 1–19**
- Training aids**
 - Controlled substance, 4–1 to 4–9
 - Controlled substance accountability, 4–4
 - Controlled substance destruction, 4–5
 - Controlled substance issue/turn-in, 4–7
 - Controlled substance procurement, 4–3
 - Controlled substance, security, 4–6
 - Explosives, 5–2
 - Explosives authorized, 5–2
 - Explosives issue/turn-in, 5–7
 - Explosives safety, 5–9
 - Explosives safety requirements, 5–11
 - Explosives storage, 5–6
 - Explosives vehicle requirements, 5–8
 - Synthetic drugs, 4–9
- Training**
 - Detector dog, 3–6
 - Explosives safety, 5–10
 - Need, 3–2
 - Nonhandler MP personnel, 3–36
 - Principles 3–3
 - Records, 3–33 to 3–35
 - When to, 3–5
- Training areas, 3–4, 7–25**
 - Safety, 7–31
- Training/evaluation of detector dogs, 3–27 to 3–32**
- Transportation**
 - Aircraft, 7–34
 - Hot weather, 7–35
 - Vehicle, 7–33
- Unattended dogs, 7–36**
- Use of MWD**
 - Accidents, 2–9
 - Billet area, 2–8
 - Building, 2–6
 - Civil disasters, 2–18
 - Confrontation, 2–15

- Escort, 2-14
- Fixed post, 2-12
- Gates, 2-13
- Housing area, 2-8
- Identification/apprehension, 2-10
- Parking lots, 2-7
- Riot/crowd control, 2-17
- Tracking, 2-16
- Traffic violations, 2-9
- Very important person protection, 2-11
- Use of force, 2-2**
- Utilization, general, 2-1**
- Utilization, records, 3-34 to 3-35**
- Validation tests, 3-32**
- Vehicles, support, 8-7**
- Veterinarian**
 - Facility safety, 7-32
 - Medical care, 6-1 to 6-2
 - Responsibilities, 6-2
 - Services, 6-1
- Walking patrols, 2-3**
- Warning signs, kennels, 7-29**
- Weight scale, 8-8**
- Wounds, 6-13**

UNCLASSIFIED

PIN 055899-000

USAPA

ELECTRONIC PUBLISHING SYSTEM

OneCol FORMATTER .WIN32 Version 133

PIN: 055899-000

DATE: 09-28-01

TIME: 14:42:38

PAGES SET: 147

DATA FILE: C:\Wincomp\suecorx.fil

DOCUMENT: DA PAM 190-12

DOC STATUS: REVISION